

# E43315

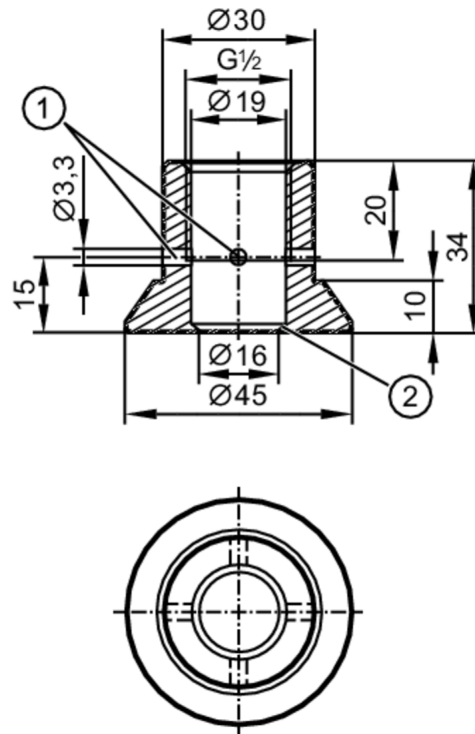

## Welding adapter for process sensors

ADAPT G1/2-WELD SHOULDER 3A



- 1 Leakage port
- 2 sealing edge



CRN EC 1935/2004 EHEDG Certified FCM FDA

Application	
Design	with leakage port
Pressure rating [bar]	50
Note on pressure rating	for the connection sensor - adapter
MAWP (for applications according to CRN) [bar]	50
Mechanical data	
Weight [g]	215
Materials	stainless steel (1.4435 / 316L)
Sensor connection	G 1/2 sealing cone
Process connection	welding adapter Ø 45 mm
Surface characteristics Ra/Rz of the wetted parts	0.4 / 4
Accessories	
Items supplied	O-rings:, FKM
Remarks	
Pack quantity	1 pcs.