

General Specifications

EJA438E Diaphragm Sealed Gauge Pressure Transmitter



GS 01C31J03-01EN

[Style: S2]

Diaphragm seal is used to prevent process medium from entering directly into the pressure-sensing assembly of the pressure transmitter, it is connected to the transmitter using capillary filled with fill fluid.

EJA438E Diaphragm Sealed Gauge Pressure Transmitters can be used to measure liquid, gas, or steam pressure. EJA438E outputs a 4 to 20 mA DC signal corresponding to the measured pressure. It also features quick response, remote setup and monitoring via BRAIN or HART communications and self-diagnostics. FOUNDATION Fieldbus, PROFIBUS PA and 1 to 5 V DC with HART (Low Power) protocol types are also available. EJA-E series models in their standard configuration, with the exception of the Fieldbus, PROFIBUS and Low Power types, are certified as complying with SIL 2 for safety requirement.



■ STANDARD SPECIFICATIONS

Refer to GS 01C31T02-01EN for Fieldbus communication type and GS 01C31T04-01EN for PROFIBUS PA communication type for the items marked with “◇”.

□ SPAN AND RANGE LIMITS

Measurement Span/Range		MPa	psi (/D1)	bar (/D3)	kgf/cm ² (/D4)	
A*1	Span	0.06 to 3.5	8.6 to 500	0.6 to 35	0.6 to 35	
	Range	-0.1 to 3.5	-14.5 to 500	-1 to 35	-1 to 35	
B	Flush type*1	Span	0.46 to 16	67 to 2300	4.6 to 160	4.6 to 160
	Range	-0.1 to 16	-14.5 to 2300	-1 to 160	-1 to 160	
Extended type*1	Span	0.46 to 7	67 to 1000	4.6 to 70	4.6 to 70	
	Range	-0.1 to 7	-14.5 to 1000	-1 to 70	-1 to 70	

*1: Measurement range is within the flange rating.

□ PERFORMANCE SPECIFICATIONS

Zero-based calibrated span, linear output, wetted parts material code SW for 3-inch flange flush type, fill fluid code B, and capillary length of 5 m. For Fieldbus and PROFIBUS PA communication types, use calibrated range instead of span in the following specifications.

Specification Conformance

EJA-E series ensures specification conformance to at least $\pm 3\sigma$.

Reference Accuracy of Calibrated Span

(includes terminal-based linearity, hysteresis, and repeatability)

Measurement span		A	B
Reference accuracy	X ≤ span	±0.2% of Span	
	X > span	±(0.16+0.004 URL/span)% of Span	
X		0.35 MPa (50 psi)	1.6 MPa (230 psi)
URL (upper range limit)		3.5 MPa (500 psi)	16 MPa (2300 psi)

Ambient Temperature Effects per 28°C (50°F) Change

Capsule	Effect
A and B	±(0.53% Span+0.025% URL)

Power Supply Effects(Output signal code D and J)
±0.005 % per Volt (from 21.6 to 32 V DC, 350Ω)

Response Time (All capsules) “◇”

200 ms (approximate value at normal temperature)
When software damping is set to zero and including dead time of 45 ms (nominal)

□ FUNCTIONAL SPECIFICATIONS

Output “◇”

For 4 to 20 mA HART / BRAIN (Output signal code D and J)

Two wire 4 to 20 mA DC output with digital communications.

BRAIN or HART FSK protocol are superimposed on the 4 to 20 mA signal.

Output range: 3.6 mA to 21.6 mA

Output limits conform to NAMUR NE43 can be preset by option code C2 or C3.

For 1 to 5 V HART (Output signal code Q)

Three or four wire low power 1 to 5 V DC output with HART, linear or square root programmable. HART protocol are superimposed on the 1 to 5 V DC signal.

Output range: 0.9 V to 5.4 V DC

Failure Alarm

For 4 to 20 mA HART / BRAIN (Output signal code D and J)

Output status at CPU failure and hardware error;

Up-scale: 110%, 21.6 mA DC or more (standard)

Down-scale: -5%, 3.2 mA DC or less

For 1 to 5 V HART (Output signal code Q)

Analog output status at CPU failure and hardware error;

Up-scale: 110%, 5.4 V DC or more (standard)

Down-scale: -5%, 0.8 V DC or less

Damping Time Constant (1st order)

Amplifier damping time constant is adjustable from 0.00 to 100.00 s by software and added to response time.

Note: For BRAIN protocol type, when amplifier software damping is set to less than 0.5 s, communication may occasionally be unavailable during the operation, especially while output changes dynamically. The default setting of damping ensures stable communication.

Update Period “◇”

Pressure: 45 ms

Zero Adjustment Limits

Zero can be fully elevated or suppressed, within the lower and upper range limits of the capsule.

External Zero Adjustment

External zero is continuously adjustable with 0.01% incremental resolution of span. Re-range can be done locally using the digital indicator with rangesetting switch.

Integral Indicator (LCD display, optional) “◇”

5-digit numerical display, 6-digit unit display and bar graph.

The indicator is configurable to display one or up to three of the following variables periodically.;

Pressure in %, scaled pressure, measured pressure.

See also “Factory Setting.”

Local Parameter Setting

(Output signal code D, J and Q)

Parameter configuration by the external zero adjustment screw and push button (Integral indicator code E) offers easy and quick setup for parameters of Loop test, Tag number, Unit, LRV, URV, Damping, Output mode (linear/square root), Display out 1, and Re-range by applying actual pressure (LRV/URV) and Device Information.

Self Diagnostics

CPU failure, hardware failure, configuration error, process alarm for pressure or capsule temperature. User-configurable process high/low alarm for pressure is also available.

Signal Characterizer

(Output signal code D, J and Q)

User-configurable 10-segment signal characterizer for 4 to 20 mA output.

Capillary Fill Fluid Density Compensation

(Output signal code D, J and Q)

Compensation of the zero shift by the ambient temperature effect on the capillary tube.

SIL Certification

EJA-E series transmitters except Fieldbus, PROFIBUS PA and 1-5V DC with HART (Low Power) communication types are certified in compliance with the following standards;

IEC 61508: 2010;

Functional Safety of Electrical/electronic/programmable electronic related systems; SIL 2 capability for single transmitter use, SIL 3 capability for dual transmitter use.

Reliability Data different depending on hardware and software revision.

For details, refer to Functional Safety Data Sheet.

(Document number: TI 01C25A05-01EN or TI 01C25A05-21EN for option code SLT)

The document can be downloaded from the website of Yokogawa.

(Website address: <https://www.yokogawa.com/solutions/products-platforms/field-instruments/>)

□ NORMAL OPERATING CONDITION (Optional features or approval codes may affect limits.)

Ambient Temperature Limits

-40 to 60°C (-40 to 140°F)

-30 to 60°C (-22 to 140°F) with LCD display

(Note: The ambient temperature limits must be within the fill fluid operating temperature range, see table 1.)

Process Temperature Limits

See table 1.

Ambient Humidity Limits

0 to 100% RH

Working Pressure Limits

See table 1.

For atmospheric pressure or below, see figure 1-1, 1-2, 1-3, 1-4, and 1-5.

Supply & Load Requirements

(Output signal code D and J. Optional features or approval codes may affect electrical requirements.)

With 24 V DC supply, up to a 550Ω load can be used. See figure 2.

Supply Voltage “◇”

For 4 to 20 mA HART / BRAIN

(Output signal code D and J)

10.5 to 42 V DC for general use and flameproof type.

10.5 to 32 V DC for lightning protector

(option code /A.)

10.5 to 30 V DC for intrinsically safe, type n, or non-incendive.

Minimum voltage limited at 16.6 V DC for digital communications, BRAIN and HART

For 1 to 5 V HART (Output signal code Q)

Power supply :

9 to 28 V DC for general use and flame proof type.

Power Consumption :

0.96 mA to 3 mA, 27 mW

Load for 4 to 20 mA HART / BRAIN

(Output signal code D and J)

0 to 1290Ω for operation

250 to 600Ω for digital communication

Output Load for 1 to 5 V HART

(Output signal code Q)

1 MΩ or greater (meter input impedance)

Note that with three-wire connection, the cable length may affect the measurement accuracy of the output signal.

Communication Requirements “◇”

(Approval codes may affect electrical requirements.)

BRAIN

Communication distance

Up to 2 km (1.25 miles) when using CEV polyethylene-insulated PVC-sheathed cables. Communication distance varies depending on type of cable used.

Load capacitance

0.22 μF or less

Load inductance

3.3 mH or less

Input impedance of communicating device

10 kΩ or more at 2.4 kHz.

EMC Conformity Standards

EN 61326-1 Class A, Table2

EN 61326-2-3

EN 61326-2-5 (for fieldbus)

European Pressure Equipment Directive

2014/68/EU

Sound Engineering Practice

EU RoHS Directive

EN 50581

Safety Requirement Standards

EN 61010-1, C22.2 No.61010-1

- Installation category: I
(Anticipated transient overvoltage 330 V)
- Pollution degree: 2
- Indoor/Outdoor use

Table 1. Process temperature, Ambient temperature, and Working pressure

	Code	Process temperature*1	Ambient temperature*2	Working pressure	Specific gravity*3
Silicone oil (general use)	A	-10 to 250°C *4 (14 to 482°F)	-10 to 60°C (14 to 140°F)	2.7 kPa abs (0.38 psi abs) to flange rating pressure	1.07
Silicone oil (general use)	B	-30 to 180°C (-22 to 356°F)	-15 to 60°C (5 to 140°F)		0.94
Silicone oil (high temperature use)	C	10 to 310°C (50 to 590°F)	10 to 60°C (50 to 140°F)		1.09
Fluorinated oil (oil-prohibited use)	D	-20 to 120°C (-4 to 248°F)	-10 to 60°C (14 to 140°F)	51 kPa abs (7.4 psi abs) to flange rating pressure	1.90 to 1.92
Ethylene glycol (low temperature use)	E	-50 to 100°C (-58 to 212°F)	-40 to 60°C (-40 to 140°F)	100 kPa abs (atmospheric pressure) to flange pressure rating	1.09
Silicone oil (high temp. and high vacuum use)	1	-10 to 250°C *4 (14 to 482°F)	-10 to 60°C *5 (14 to 140°F)	0.013 kPa abs (0.0019 psi abs) to flange rating pressure	1.07
Silicone oil (high temp. and high vacuum use)	2	10 to 310°C (50 to 590°F)	10 to 60°C *5 (50 to 140°F)		1.09
Silicone oil (high vacuum use)	4	-10 to 100°C (14 to 212°F)	-10 to 60°C *5 (14 to 140°F)		1.07

*1: See figure 1-1, 1-2, 1-3, 1-4, and 1-5 'Working Pressure and Process Temperature.'

*2: This ambient temperature is the transmitter ambient temperature.

*3: Approximate values at a temperature of 25°C (77°F)

*4: In case of wetted parts material code TW (Tantalum), process temperature limit is up to 200°C (392°F).

*5: The upper ambient temperature limit is 50°(122°F) in the following combinations.

Process connection style code	Process connection size code
W (Flush type)	2 (2-inch) or 8 (1 1/2-inch)
E (Extension type)	3 (3-inch)

Note: The differential pressure transmitter should be installed at least 600 mm below the high pressure (HP) process connection. However, this value (600 mm) may be affected by ambient temperature, operating pressure, fill fluid or material of the wetted diaphragm.

Contact YOKOGAWA when the transmitter can not be installed at least 600 mm below the HP process connection.

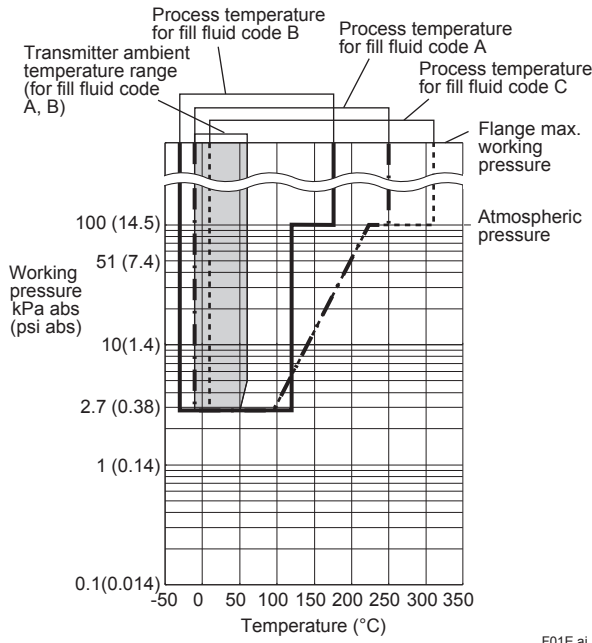

F01E.ai

Figure 1-1. Working Pressure and Process Temperature (Fill fluid: silicone oil for general and high temperature use)

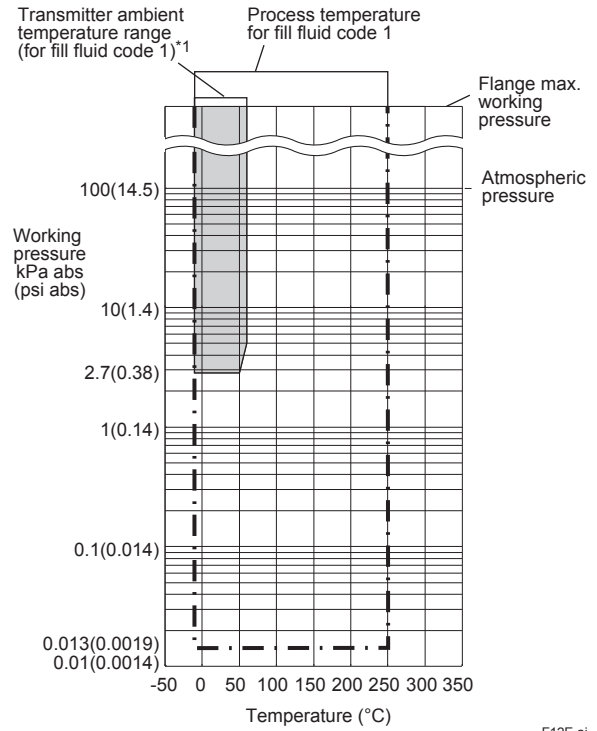

F12E.ai

Figure 1-3. Working Pressure and Process Temperature (Fill fluid: silicone oil for high temp. and high vacuum use)

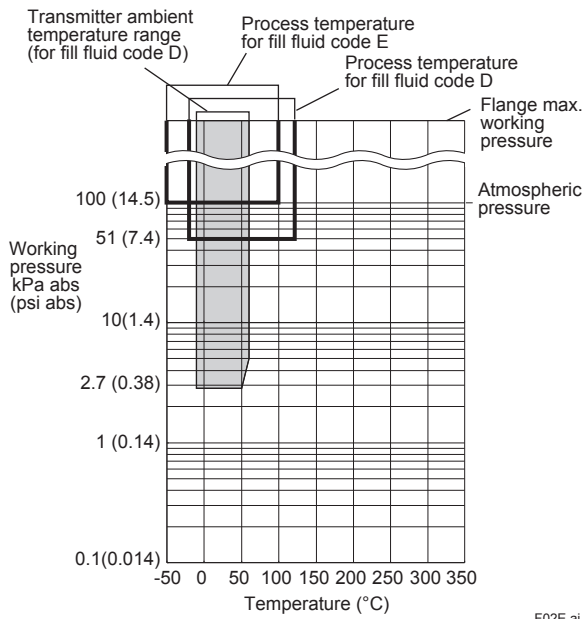

F02E.ai

Figure 1-2. Working Pressure and Process Temperature (Fill fluid: fluorinated oil for oil-prohibited use and ethylene glycol for low temperature use)

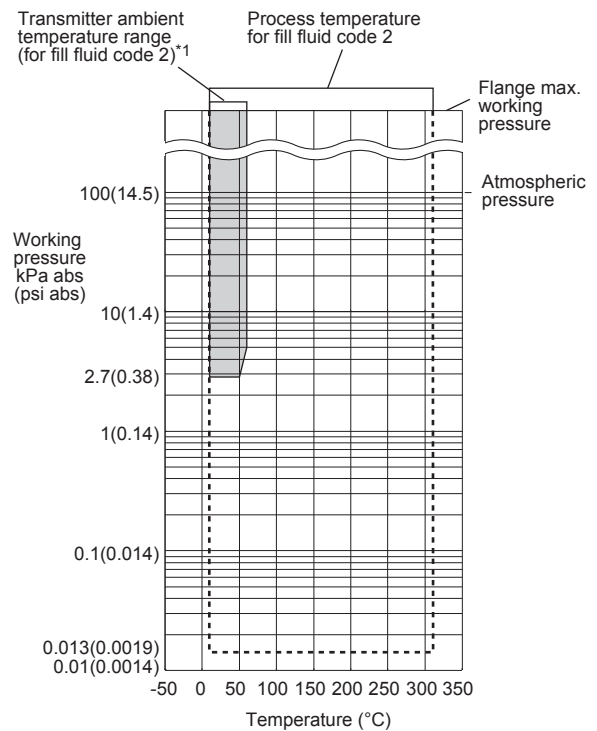

F13E.ai

Figure 1-4. Working Pressure and Process Temperature (Fill fluid: silicone oil for high temp. and high vacuum use)

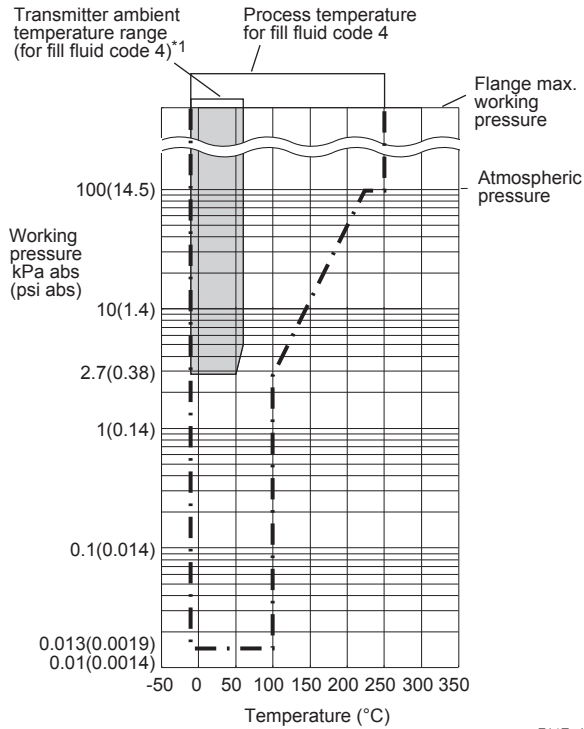

Figure 1-5. Working Pressure and Process Temperature (Fill fluid: silicone oil for high vacuum use)

*1: The upper ambient temperature limit is 50°(122°F) in the following combinations.

Process connection style code	Process connection size code
W (Flush type)	2 (2-inch) or 8 (1 1/2-inch)
E (Extension type)	3 (3-inch)

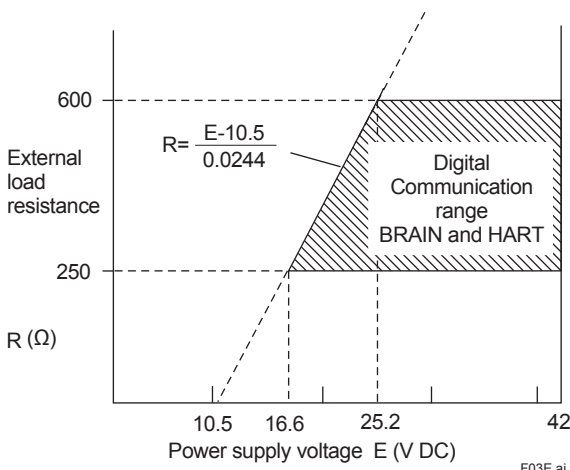

Figure 2. Relationship Between Power Supply Voltage and External Load Resistance (Output signal code D and J)

□ **PHYSICAL SPECIFICATIONS**

Process connections

See the following table.

Table 2. Flange size and rating

Process connection style	Size	Flange
Flush type	3-inch 2-inch 1 1/2-inch*	JIS 10K, 20K, 40K, 63K ANSI Class 150, 300, 600 JPI Class 150, 300, 600 DIN PN10/16, 25/40, 64
Extended type	4-inch 3-inch	JIS 10K, 20K, 40K ANSI Class 150, 300 JPI Class 150, 300 DIN PN10/16, 25/40

*: Flushing connection ring is always attached.

Gasket Contact Surface

See the following table.

Table 3. Gasket contact surface

Flange	JIS/JPI/DIN		ANSI	
	SW, SE	HW, TW, UW	SW, SE	HW, TW, UW
Wetted parts material code				
Gasket contact Surface	Serration*1	—	●	—
	Flat (No serration)	●	●	●

- : Applicable
- : Not applicable
- *1: ANSI B16.5

Electrical Connections

See "MODEL AND SUFFIX CODES."

Transmitter Mounting

2-inch pipe mounting

Wetted Parts Materials

Diaphragm seal

Diaphragm and other wetted parts;
Refer to "MODEL AND SUFFIX CODES."

Flushing connection ring (optional)

Ring and Vent / Drain plugs
Refer to "MODEL AND SUFFIX CODES."
(Spiral) gasket for transmitter side
316SST (Hoop), PTFE Teflon (Filler)

Non-wetted Parts Materials

Transmitter body section:

- Cover flange**
ASTM CF-8M
- Cover flange bolting**
B7 carbon steel, 316L SST or 660 SST
- Housing**
 - Low copper cast aluminum alloy
 - Low copper cast aluminum alloy with corrosion resistance properties (copper content ≤ 0.03%, iron content ≤ 0.15%) (optional)
 - ASTM CF-8M Stainless steel (optional)

Coating of housing

[for aluminum housing]
Polyester resin powder coating
Mint-green paint (Munsell 5.6BG 3.3/2.9 or its equivalent)
[for option code /P□ or /X2]
Epoxy and polyurethane resin solvent coating

I. Transmitter body section

EJA438E - [] - [] - [] - []

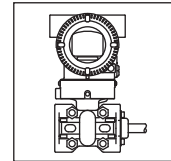

F05E.ai

Model	Suffix Codes	Description
EJA438E	Diaphragm sealed gauge pressure transmitter
Output signal	-D -J -F -G -Q	4 to 20 mA DC with digital communication (BRAIN protocol) 4 to 20 mA DC with digital communication (HART 5/HART 7 protocol)*1 Digital communication (FOUNDATION Fieldbus protocol, refer to GS 01C31T02-01EN) Digital communication (PROFIBUS PA protocol, refer to GS 01C31T04-01EN) Low Power, 1 to 5 V DC with digital communication (HART 7 protocol)*8
Measurement span (capsule)	A B	0.06 to 3.5 MPa (8.6 to 500 psi) 0.46 to 16 MPa (67 to 2300 psi)*2
—	S	Always S
—	C	Always C
Coverflange bolts and nuts material	J G C	B7 carbon steel 316L SST 660 SST
Installation	-9	Horizontal piping type and left side high pressure
Amplifier housing	1 3 2	Cast aluminum alloy Cast aluminum alloy with corrosion resistance properties*3 ASTM CF-8M stainless steel*4
Electrical connection	▶ 0 2 4 5 7 9 A C D	G 1/2 female, one electrical connection without blind plugs 1/2 NPT female, two electrical connections without blind plugs M20 female, two electrical connections without blind plugs G 1/2 female, two electrical connections with a blind plug *5 1/2 NPT female, two electrical connections with a blind plug *5 M20 female, two electrical connections with a blind plug *5 G 1/2 female, two electrical connections and a 316 SST blind plug 1/2 NPT female, two electrical connections and a 316 SST blind plug M20 female, two electrical connections and a 316 SST blind plug
Integral indicator	▶ D E N	Digital indicator*6 Digital indicator with the range setting switch (push button)*7 None
Mounting bracket	▶ B J N	304 SST 2-inch pipe mounting, flat type (for horizontal piping) 316 SST 2-inch pipe mounting, flat type (for horizontal piping) None
Diaphragm seal section		- [] - [] Continued on diaphragm seal section (II)

The “▶” marks indicate the most typical selection for each specification.

- *1: HART 5 or HART 7 is selectable. Specify upon ordering.
- *2: When specified process connection style code E, maximum range and span are 7 MPa (1000 psi.)
- *3: Not applicable for electrical connection code 0, 5, 7, 9 and A.
- *4: Not applicable for electrical connection code 0, 5, 7 and 9.
- *5: Material of a blind plug; aluminum alloy for code 5 and 9, and SUS304 for code 7.
- *6: Not applicable for output signal code G.
- *7: Not applicable for output signal code F.
- *8: As CE marking is still pending, not applicable for those countries which require CE marking.

II. Diaphragm seal section (Flush type)

- Process connection size: 3-inch (80mm) / 2-inch (50mm)

EJA438E- [] [] [] [] - [] [] [] [] - W [] [] ³/₂ [] [] [] [] - [] [] [] []

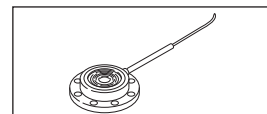

F06E.ai

Model	Suffix codes	Description																											
EJA438E	- [] [] [] [] - [] [] [] []	Transmitter body section (I)																											
Process connection style	-W	Flush type																											
Flange rating	J1 J2 J4 J6 A1 A2 A4 D2 D4 D5 P1 P2 P4	JIS 10K JIS 20K JIS 40K JIS 63K ANSI class 150 ANSI class 300 ANSI class 600 DIN PN10/16 DIN PN25/40 DIN PN64 JPI class 150 JPI class 300 JPI class 600																											
Process connection size (Process flange size)	3 2	3-inch (80 mm) 2-inch (50 mm)																											
Flange material	▶ A B C	JIS S25C 304 SST *11 316 SST *11																											
Gasket contact surface*1	1 2	Serration (for ANSI flange with wetted parts material SW only) Flat (no serration)																											
Wetted parts material*10	SW HW TW UW	<table border="0"> <tr> <td>[Diaphragm]</td> <td>[Others]</td> </tr> <tr> <td>316L SST</td> <td>316L SST</td> </tr> <tr> <td>Hastelloy C-276*9#</td> <td>Hastelloy C-276*9#</td> </tr> <tr> <td>Tantalum *7</td> <td>Tantalum *7</td> </tr> <tr> <td>Titanium</td> <td>Titanium</td> </tr> </table>	[Diaphragm]	[Others]	316L SST	316L SST	Hastelloy C-276*9#	Hastelloy C-276*9#	Tantalum *7	Tantalum *7	Titanium	Titanium																	
[Diaphragm]	[Others]																												
316L SST	316L SST																												
Hastelloy C-276*9#	Hastelloy C-276*9#																												
Tantalum *7	Tantalum *7																												
Titanium	Titanium																												
Flushing connection ring*2	▶ 0 A B	<table border="0"> <tr> <td>[Ring]</td> <td>[Vent/Drain plugs]</td> <td>[Material]</td> </tr> <tr> <td>None</td> <td>—</td> <td>—</td> </tr> <tr> <td>Straight type</td> <td>R 1/4 connections*8</td> <td>316 SST #</td> </tr> <tr> <td>Straight type</td> <td>1/4 NPT connections</td> <td>316 SST #</td> </tr> </table>	[Ring]	[Vent/Drain plugs]	[Material]	None	—	—	Straight type	R 1/4 connections*8	316 SST #	Straight type	1/4 NPT connections	316 SST #															
[Ring]	[Vent/Drain plugs]	[Material]																											
None	—	—																											
Straight type	R 1/4 connections*8	316 SST #																											
Straight type	1/4 NPT connections	316 SST #																											
Extension	0	None																											
Fill fluid	▶ -A -B -C -D -E -1 -2 -4	<table border="0"> <tr> <td></td> <td>[Process temperature]</td> <td>[Ambient temperature]</td> </tr> <tr> <td>For general use (silicone oil)*3</td> <td>-10 to 250°C</td> <td>-10 to 60°C</td> </tr> <tr> <td>For general use (silicone oil)</td> <td>-30 to 180°C</td> <td>-15 to 60°C</td> </tr> <tr> <td>For high temperature use (silicone oil)*4*7</td> <td>10 to 310°C</td> <td>10 to 60°C</td> </tr> <tr> <td>For oil-prohibited use (fluorinated oil)*5</td> <td>-20 to 120°C</td> <td>-10 to 60°C</td> </tr> <tr> <td>For low temperature use (ethylene glycol)</td> <td>-50 to 100°C</td> <td>-40 to 60°C</td> </tr> <tr> <td>High temp. and high vacuum use (Silicone oil)*3*12</td> <td>-10 to 250°C</td> <td>-10 to 60°C(50°C)*13</td> </tr> <tr> <td>High temp. and high vacuum use (Silicone oil)*4*7*12</td> <td>10 to 310°C</td> <td>10 to 60°C(50°C)*13</td> </tr> <tr> <td>High vacuum use (Silicone oil)*12</td> <td>-10 to 100°C</td> <td>-10 to 60°C(50°C)*13</td> </tr> </table>		[Process temperature]	[Ambient temperature]	For general use (silicone oil)*3	-10 to 250°C	-10 to 60°C	For general use (silicone oil)	-30 to 180°C	-15 to 60°C	For high temperature use (silicone oil)*4*7	10 to 310°C	10 to 60°C	For oil-prohibited use (fluorinated oil)*5	-20 to 120°C	-10 to 60°C	For low temperature use (ethylene glycol)	-50 to 100°C	-40 to 60°C	High temp. and high vacuum use (Silicone oil)*3*12	-10 to 250°C	-10 to 60°C(50°C)*13	High temp. and high vacuum use (Silicone oil)*4*7*12	10 to 310°C	10 to 60°C(50°C)*13	High vacuum use (Silicone oil)*12	-10 to 100°C	-10 to 60°C(50°C)*13
	[Process temperature]	[Ambient temperature]																											
For general use (silicone oil)*3	-10 to 250°C	-10 to 60°C																											
For general use (silicone oil)	-30 to 180°C	-15 to 60°C																											
For high temperature use (silicone oil)*4*7	10 to 310°C	10 to 60°C																											
For oil-prohibited use (fluorinated oil)*5	-20 to 120°C	-10 to 60°C																											
For low temperature use (ethylene glycol)	-50 to 100°C	-40 to 60°C																											
High temp. and high vacuum use (Silicone oil)*3*12	-10 to 250°C	-10 to 60°C(50°C)*13																											
High temp. and high vacuum use (Silicone oil)*4*7*12	10 to 310°C	10 to 60°C(50°C)*13																											
High vacuum use (Silicone oil)*12	-10 to 100°C	-10 to 60°C(50°C)*13																											
Capillary connection	A	Side of diaphragm seal unit																											
—	2	Always 2																											
Capillary length*6	1 ... 2 ... 3 ... 4 ... 5 ...	6 6 m 7 7 m 8 8 m 9 9 m A 10 m																											
Option codes		/□ Optional specification																											

The “▶” marks indicate the most typical selection for each specification.

Example: EJA438E-DASCG-912EN-WA13B1SW00-BA25/□

- *1: See table 3 ‘Gasket contact surface’ on page 5.
- *2: When specified flushing connection ring code A or B, exclusive gasket is provided for transmitter side.
- *3: In case of wetted parts material code TW (Tantalum), the process temperature limit is –10 to 200°C.
- *4: Wetted parts material code TW (Tantalum) cannot be applied.
- *5: Even in case where fill fluid code D (fluorinated oil) is selected, if degrease cleansing treatment or both degrease cleansing and dehydrating treatment for the wetted parts is required, specify option code K1 or K5.
- *6: In case of wetted parts material code HW (Hastelloy C), TW (Tantalum), and UW (Titanuym) for 2-inch pressure flange, specify capillary length from 1 to 5 m.
- *7: Not applicable for flashing connection ring code A and B.
- *8: Not applicable for gasket contact surface code 1.
- *9: Hastelloy C-276 or N10276.
- *10: ⚠ Users must consider the characteristics of selected wetted parts material and the influence of process fluids. The use of inappropriate materials can result in the leakage of corrosive process fluids and cause injury to personnel and/or damage to plant facilities. It is also possible that the diaphragm itself can be damaged and that material from the broken diaphragm and the fill fluid can contaminate the user’s process fluids.
Be very careful with highly corrosive process fluids such as hydrochloric acid, sulfuric acid, hydrogen sulfide, sodium hypochlorite, and hightemperature steam (150°C [302°F] or above). Contact Yokogawa for detailed information of the wetted parts material.
- *11: Forged version of the material may be used.
- *12: Not applicable for wetted parts material code UW.
- *13: The upper ambient temperature limit is 50°(122°F) when specifying process connection size code 2 (2-inch).

The # marks indicate the construction materials conform to NACE material recommendations per MR0175/ISO 15156.

Please refer to the latest standards for details. Selected materials also conform to NACE MR0103.

II. Diaphragm seal section (Flush type)

● Process connection size: 1 1/2-inch (40 mm)

EJA438E- □□□□ - □□□□ - W 8 □□□□□□ - □□□□

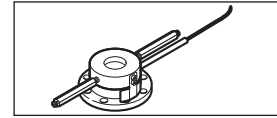

F07E.ai

Model	Suffix codes	Description
EJA438E	-□□□□□-□□□□□	Transmitter body section (I)
Process connection style	-W	Flush type
Flange rating	J1 J2 J4 A1 A2 A4 P1 P2 P4	JIS 10K JIS 20K JIS 40K ANSI class 150 ANSI class 300 ANSI class 600 JPI class 150 JPI class 300 JPI class 600
Process connection size (Process flange size)	8	1 1/2-inch (40 mm)
Flange material	A B C	JIS S25C 304 SST *6 316 SST *6
Gasket contact surface*1	1 2	Serration (for ANSI flange only) Flat (no serration)
Wetted parts material*5	SW	[Diaphragm] 316L SST [Others] 316L SST
Flushing connection ring*2	C D	[Ring] Reducer type [Vent/Drain plugs] R 1/4 connections*4 [Material] 316 SST # [Ring] Reducer type [Vent/Drain plugs] 1/4 NPT connections [Material] 316 SST #
Extension	0	None
Fill fluid	-A -B -D -E -1 -4	[Process temperature] [Ambient temperature] For general use (silicone oil) -10 to 250°C -10 to 60°C For general use (silicone oil) -30 to 180°C -15 to 60°C For oil-prohibited use (fluorinated oil)*3 -20 to 120°C -10 to 60°C For low temperature use (ethylene glycol) -50 to 100°C -40 to 60°C High temp. and high vacuum use (Silicone oil) -10 to 250°C -10 to 50°C High vacuum use (Silicone oil) -10 to 100°C -10 to 50°C
Capillary connection	A	Side of diaphragm seal unit
-	2	Always 2
Capillary length	1... 2... 3... 4... 5... 6... 7... 8... 9... A...	1 m 2 m 3 m 4 m 5 m 6 m 7 m 8 m 9 m 10 m
Option codes		/□ Optional specification

The “►” marks indicate the most typical selection for each specification.

Example: EJA438E-DASCG-912EN-WA18B1SWD0-BA25/□

*1: See table 3 ‘Gasket contact surface’ on page 5.

*2: When specified flushing connection ring code C or D, exclusive gasket is provided for transmitter side.

*3: Even in case where fill fluid code D (fluorinated oil) is selected, if degrease cleansing treatment or both degrease cleansing and dehydrating treatment for the wetted parts is required, specify option code K1 or K5.

*4: Not applicable for gasket contact surface code 1.

*5: ⚠ Users must consider the characteristics of selected wetted parts material and the influence of process fluids. The use of inappropriate materials can result in the leakage of corrosive process fluids and cause injury to personnel and/or damage to plant facilities. It is also possible that the diaphragm itself can be damaged and that material from the broken diaphragm and the fill fluid can contaminate the user’s process fluids.

Be very careful with highly corrosive process fluids such as hydrochloric acid, sulfuric acid, hydrogen sulfide, sodium hypochlorite, and hightemperature steam (150°C [302°F] or above). Contact Yokogawa for detailed information of the wetted parts material.

*6: Forged version of the material may be used.

-
- *4: ⚠ Users must consider the characteristics of selected wetted parts material and the influence of process fluids. The use of inappropriate materials can result in the leakage of corrosive process fluids and cause injury to personnel and/or damage to plant facilities. It is also possible that the diaphragm itself can be damaged and that material from the broken diaphragm and the fill fluid can contaminate the user's process fluids.
Be very careful with highly corrosive process fluids such as hydrochloric acid, sulfuric acid, hydrogen sulfide, sodium hypochlorite, and hightemperature steam (150°C [302°F] or above). Contact Yokogawa for detailed information of the wetted parts material.
 - *5: Forged version of the material may be used.
 - *6: The upper ambient temperature limit is 50°(122°F) when specifying process connection size code 3 (3-inch).

■ OPTIONAL SPECIFICATIONS (For Explosion Protected type) “◇”

For other agency approvals and marine approvals, please refer to GS 01C25A20-01EN.

Item	Description	Code
Factory Mutual (FM)	FM Explosionproof Approval ^{**1} Applicable Standard: FM3600, FM3615, FM3810, NEMA 250, ANSI/UL 61010-1, ANSI/UL 61010-2-30 Explosionproof for Class I, Division 1, Groups B, C and D, Dust-ignitionproof for Class II/III, Division 1, Groups E, F and G, in Hazardous locations, indoors and outdoors (Enclosure: Type 4X) “FACTORY SEALED, CONDUIT SEAL NOT REQUIRED.” Temperature class: T6, Amb. Temp.: -40 to 60°C (-40 to 140°F)	FF1
	FM Intrinsically safe Approval ^{**1,3} Applicable Standard: FM 3600, FM 3610, FM 3611, FM 3810, ANSI/ISA-60079-0, ANSI/ISA-60079-11, ANSI/ISA-61010-1, NEMA 250 Intrinsically Safe for Class I, Division 1, Groups A, B, C & D, Class II, Division 1, Groups E, F & G and Class III, Division 1, Class I, Zone 0, in Hazardous Locations, AEx ia IIC Nonincendive for Class I, Division 2, Groups A, B, C & D, Class II, Division. 2, Groups F & G, Class I, Zone 2, Group IIC, in Hazardous Locations Enclosure: Type 4X, Temp. Class: T4, Amb. Temp.: -60 to 60°C (-75 to 140°F) Intrinsically Safe Apparatus Parameters [Groups A, B, C, D, E, F and G] Vmax=30 V, Imax=200 mA, Pmax=1 W, Ci=6 nF, Li=0 μH [Groups C, D, E, F and G] Vmax=30 V, Imax=225 mA, Pmax=1 W, Ci=6 nF, Li=0 μH	FS1
	Combined FF1 and FS1 ^{**1,3}	FU1
ATEX	ATEX Flameproof Approval ^{**1,3} Applicable Standard: EN IEC 60079-0, EN 60079-1, EN 60079-31 Certificate: KEMA 07ATEX0109 X II 2G, 2D Ex db IIC T6...T4 Gb, Ex tb IIIC T85°C Db Degree of protection: IP66/IP67 Amb. Temp. (Tamb) for gas-proof : T4; -50 to 75°C (-58 to 167°F), T5; -50 to 80°C (-58 to 176°F), T6; -50 to 75°C (-58 to 167°F) Process Temp. for gas-proof (Tp): T4; -50 to 120°C (-58 to 248°F), T5; -50 to 100°C (-58 to 212°F), T6; -50 to 85°C (-58 to 185°F) Max. surface Temp. for dust-proof: T85°C (Tamb: -30 to 75°C, Tp: -30 to 85°C) ^{*2}	KF22
	ATEX Intrinsically safe Approval ^{**1,3} Applicable Standard: EN 60079-0, EN 60079-11 Certificate: DEKRA 11ATEX0228 X II 1G, 2D Ex ia IIC T4 Ga, Ex ia IIIC T85°C T100°C T120°C Db Degree of protection: IP66/IP67 Amb. Temp. (Tamb) for EPL Ga: -50 to 60°C (-58 to 140°F) Maximum Process Temp. (Tp) for EPL Ga: 120°C Electrical data: Ui=30 V, Ii=200 mA, Pi=0.9 W, Ci=27.6 nF, Li=0 μH Amb. Temp. for EPL Db: -30 to 60°C ^{*2} Max. surface Temp. for EPL Db: T85°C (Tp: 80°C), T100°C (Tp: 100°C), T120°C (Tp: 120°C)	KS21
	Combined KF22, KS21 and ATEX Intrinsically safe Ex ic ^{**1,3} [ATEX Intrinsically safe Ex ic] Applicable Standard: EN 60079-0, EN 60079-11 II 3G Ex ic IIC T4 Gc, Amb. Temp.: -30 to 60°C (-22 to 140°F) ^{*2} Ui=30 V, Ci=27.6 nF, Li=0 μH	KU22

Item	Description	Code
Canadian Standards Association (CSA)	<p>CSA Explosionproof Approval *1 Certificate: 2014354 Applicable Standard: C22.2 No. 25, C22.2 No. 30, CAN/CSA-C22.2 No. 94, CAN/CSA-C22.2 No. 61010-1, CAN/CSA-C22.2 No. 61010-2-030, CAN/CSA-C22.2 No. 60079-0, CAN/CSA-C22.2 No. 60079-1, CAN/CSA-C22.2 No. 60529 Explosion-proof for Class I, Groups B, C and D. Dustignition-proof for Class II/III, Groups E, F and G. When installed in Division 2, "SEAL NOT REQUIRED" Enclosure: Type 4X, Temp. Code: T6...T4 Ex d IIC T6...T4 Enclosure: IP66/IP67 Max.Process Temp.: T4;120°C(248°F), T5;100°C(212°F), T6; 85°C(185°F) Amb.Temp.: -50 to 75°C(-58 to 167°F) for T4, -50 to 80°C(-58 to 176°F) for T5, -50 to 75°C(-58 to 167°F) for T6 *2 Process Sealing Certification Dual Seal Certified by CSA to the requirement of ANSI/ISA-12.27.01 No additional sealing required Primary seal failure annunciation: at the zero adjustment screw</p>	CF1
	<p>CSA Intrinsically safe Approval **3 Certificate: 1606623 [For Division System] Applicable Standard: C22.2 No.0, C22.2 No.94, C22.2 No.157, C22.2 No.213, C22.2 No.61010-1, C22.2 No.61010-2-030 Intrinsically Safe for Class I, Division 1, Groups A, B, C & D, Class II, Division 1, Groups E, F & G, Class III, Division 1, Nonincendive for Class I, Division 2, Groups A, B, C & D, Class II, Division 2, Groups F & G, Class III, Division 1 Enclosure: Type 4X, Temp. Code: T4 Amb. Temp.: -50 to 60°C(-58 to 140°F) *2 Electrical Parameters: [Intrinsically Safe] Vmax=30V, Imax=200mA, Pmax=0.9W, Ci=10nF, Li=0 μH [Nonincendive] Vmax=30V, Ci=10nF, Li=0 μH [For Zone System] Applicable Standard: CAN/CSA-C22.2 60079-0, CAN/CSA-E60079-11, CAN/CSA-E60079-15, CAN/CSA-C22.2 No.60529 Ex ia IIC T4, Ex nL IIC T4 Enclosure: IP66/IP67 Amb. Temp.: -50 to 60°C(-58 to 140°F) *2, Max. Process Temp.: 120°C(248°F) Electrical Parameters: [Ex ia] Ui=30V, li=200mA, Pi=0.9W, Ci=10nF, Li=0 μH [Ex nL] Ui=30V, Ci=10nF, Li=0 μH Process Sealing Certification Dual Seal Certified by CSA to the requirement of ANSI/ISA-12.27.01 No additional sealing required Primary seal failure annunciation: at the zero adjustment screw</p>	CS1
	Combined CF1 and CS1 **3	CU1
IECEX	<p>IECEX Flameproof Approval *1 Applicable Standard: IEC 60079-0, IEC60079-1 Certificate: IECEX CSA 07.0008 Flameproof for Zone 1, Ex d IIC T6...T4 Gb Enclosure: IP66/IP67 Max.Process Temp.: T4;120°C(248°F), T5;100°C(212°F), T6; 85°C(185°F) Amb.Temp.: -50 to 75°C(-58 to 167°F) for T4, -50 to 80°C(-58 to 176°F) for T5, -50 to 75°C(-58 to 167°F) for T6</p>	SF2
	<p>IECEX Intrinsically safe and Flameproof Approval **3 Intrinsically safe Ex ia Certificate: IECEX DEK 11.0081X Applicable Standard: IEC 60079-0, IEC 60079-11 Ex ia IIC T4 Ga Enclosure: IP66/IP67 Amb. Temp.: -50 to 60 °C(-58 to 140 °F), Max. Process Temp.: 120 °C(248 °F) Electrical Parameters: Ui=30 V, li=200 mA, Pi=0.9 W, Ci=27.6 nF, Li=0 μH Intrinsically safe Ex ic Certificate: IECEX DEK 13.0061X Applicable Standard: IEC 60079-0, IEC 60079-11 Ex ic IIC T4 Gc IP code: IP66 Amb. Temp.: -30 to 60°C(-22 to 140°F) *2, Max. Process Temp.: 120°C(248°F) Electrical Parameters: Ui=30V,Ci=27.6 nF, Li=0 μH Flameproof Certificate: IECEX CSA 07.0008 Applicable Standard: IEC 60079-0, IEC60079-1 Flameproof for Zone 1, Ex d IIC T6...T4 Gb Enclosure: IP66/IP67 Max.Process Temp.: T4;120°C(248°F), T5;100°C(212°F), T6; 85°C(185°F) Amb.Temp.: -50 to 75°C(-58 to 167°F) for T4, -50 to 80°C(-58 to 176°F) for T5, -50 to 75°C(-58 to 167°F) for T6</p>	SU21

*1: Applicable for Electrical connection code 2, 4, 7, 9, C and D.
 *2: Lower limit of ambient temperature is -15°C (5°F) when /HE is specified.
 *3: Not applicable for output signal code Q.

■ OPTIONAL SPECIFICATIONS

Item		Description	Code	
Painting	Color change	Amplifier cover only *1	P□	
		Amplifier cover and terminal cover, Munsell 7.5 R4/14	PR	
	Coating change	Anti-corrosion coating *2	X2	
316 SST exterior parts		316 SST zero-adjustment screw and setscrews *4	HC	
Fluoro-rubber O-ring		All O-rings of amplifier housing. Lower limit of ambient temperature: -15°C (5°F)	HE	
Lightning protector		Transmitter power supply voltage: 10.5 to 32 V DC (10.5 to 30 V DC for intrinsically safe type.) Allowable current: Max. 6000 A (1×40 μs), Repeating 1000 A (1×40 μs) 100 times Applicable Standards: IEC 61000-4-4, IEC 61000-4-5	A	
Oil-prohibited use		Degrease cleansing treatment	K1	
Oil-prohibited use with dehydrating treatment		Degrease cleansing and dehydrating treatment	K5	
Calibration units *5	P calibration (psi unit)		D1	
	bar calibration (bar unit)		D3	
	M calibration (kgf/cm ² unit)		D4	
		(See Table for Span and Range Limits.)		
Teflon film *6 *7 *17		Diaphragm protection from sticky process fluid by FEP Teflon film attached with fluorinated oil. Operation range: 20 to 150°C, 0 to 2 MPa (Not applicable for vacuum service).	TF1	
Operating temperature correction *8		Adjusting range: 80°C to Maximum temperature of specified fill fluid	R	
Capillary without PVC sheaths		When ambient temperature exceeds 100°C, or use of PVC is prohibited	V	
Output limits and failure operation *9		Failure alarm down-scale: Output status at CPU failure and hardware error is -5%, 3.2mA DC or less for 4 to 20 mA output type, and -5%, 0.8V DC or less for 1 to 5 V output type.	C1	
		NAMUR NE43 Compliant Output signal limits: 3.8 mA to 20.5 mA *18	C2	
		Failure alarm up-scale: Output status at CPU failure and hardware error is 110%, 21.6 mA or more.	C3	
Gold-plated diaphragm *10		Inside of isolating diaphragms (fill fluid side) are gold plated, effective for hydrogen permeation.	A1	
Wired tag plate		316 SST tag plate wired onto transmitter (Tag No.: Maximum. 16 characters.)	N4	
Data configuration at factory *11		Data configuration for HART communication type	Software damping, Descriptor, Message	
		Data configuration for BRAIN communication type	Software damping	
Material certificate		Process flange, Block	For Flush type	
		Process flange, Block, Ring *12		
		Process flange, Block, Pipe, Base	For Extended type	
Pressure test/ Leak test certificate *13*14	For A-Capsule	[Flange rating]	[Test pressure]	
		JIS 10K	2 MPa (290 psi)	T51
		JIS 20K, 40K, 63K	3.5 MPa (500 psi)	T53
		ANSI/JPI Class 150	3 MPa (430 psi)	T52
	For B-Capsule	ANSI/JPI Class 300, 600	3.5 MPa (500 psi)	T53
		JIS 10K	2 MPa (290 psi)	T51
		JIS 20K	5 MPa (720 psi)	T54
		JIS 40K *6	10 MPa (1450 psi)	T57
		JIS 40K *15	7 MPa (1000 psi)	T55
		JIS 63K *6	16 MPa (2300 psi)	T58
		ANSI/JPI Class 150	3 MPa (430 psi)	T52
		ANSI/JPI Class 300 *6	8 MPa (1160 psi)	T56
		ANSI/JPI Class 300 *15	7 MPa (1000 psi)	T55
		ANSI/JPI Class 600 *6	16 MPa (2300 psi)	T58
				Nitrogen Gas *16 Retention time: one minute
Parameter list *19		List of setting and adjustment parameters	YP	

*1: Not applicable for amplifier housing code 2 and 3.

*2: Not applicable with color change option. Not applicable for amplifier housing code 2.

*3: The specification is included in amplifier code 2.

*4: 316 or 316L SST. The specification is included in amplifier code 2.

*5: The unit of MWP (Max. working pressure) on the name plate of a housing is the same unit as specified by option code D1, D3, and D4.

*6: Applicable for flush type (process connection style code W.)

*7: Applicable for flushing connection ring code 0.

*8: Specify the process operating temperature for zero correction. Example: Zero correction by process temperature 90°C.

*9: Applicable for output signal code D and J. The hardware error indicates faulty amplifier or capsule.

*10: Applicable for wetted parts material code SW, SE, and HW.

*11: Also see 'Ordering Information.'

- *12: Applicable for flushing connection ring code A, B, C, and D.
- *13: The unit on the certificate is always MPa regardless of selection of option code D1, D3, or D4.
- *14: A flushing connection ring will not be applied when conducting the pressure test or leak test.
- *15: Applicable for extended type (process connection style code E.)
- *16: Dry nitrogen gas is used for oil-prohibited use (option code K1 and K5.)
- *17: Not applicable for Fill fluid code 1, 2, or 4.
- *18: The 1 to 5 V voltage output corresponding to 4 to 20 mA current output is applied to output signal code Q which is non-compliant to NAMUR NE43.
- *19: Applicable for output signal code D and J.

■ DIMENSIONS

Unit: mm (approx.inch)

< Transmitter body section >

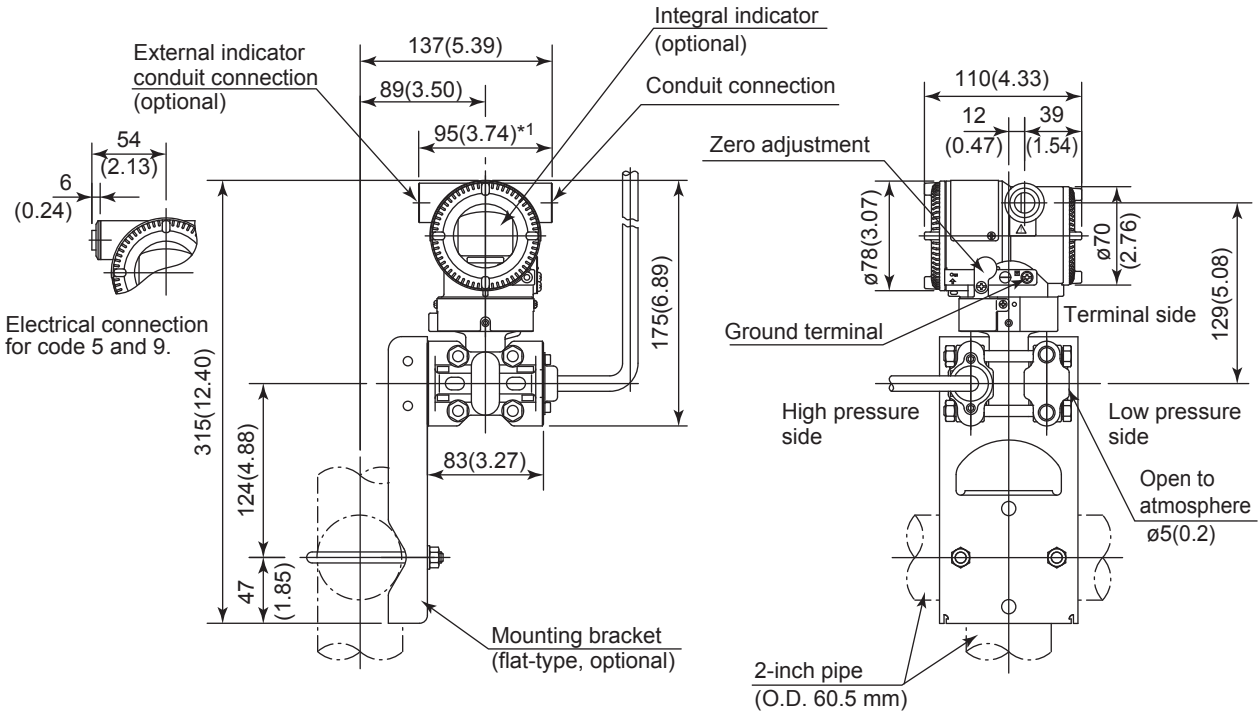

*1: When electrical connection code 7 or C is selected, a blind plug is protruded upto 8 mm (0.31 inch) from the conduit connection.

F09E.ai

● Terminal Configuration

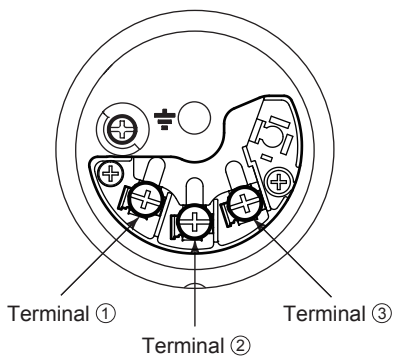

● Terminal Wiring for 4 to 20 mA output, FOUNDATION Fieldbus and PROFIBUS PA communication types

SUPPLY	+	①] Power supply and output terminals
	-	②	
CHECK	+	③] External indicator (ammeter) terminals*1*2
	-	②	
			⏏ Ground terminal

*1: When using an external indicator or check meter, the internal resistance must be 10 Ω or less.

*2: Not available for FOUNDATION Fieldbus and PROFIBUS PA communication types.

● Terminal Wiring for 1 to 5 V output

SUPPLY	+	①] Power supply terminals
	-	②	
VOUT	+	③] 1 to 5 V DC with HART communication terminals
	-	②	
			⏏ Ground terminal

Three or four wire connection. For four wire connection, both supply and signal lines use SUPPLY - terminal.

F11E.ai

< Diaphragm seal section >

Unit: mm (approx.inch)

• Flush type

• No ring (Flushing connection ring code 0)

• With ring (Flushing connection ring code A, B, C, and D)

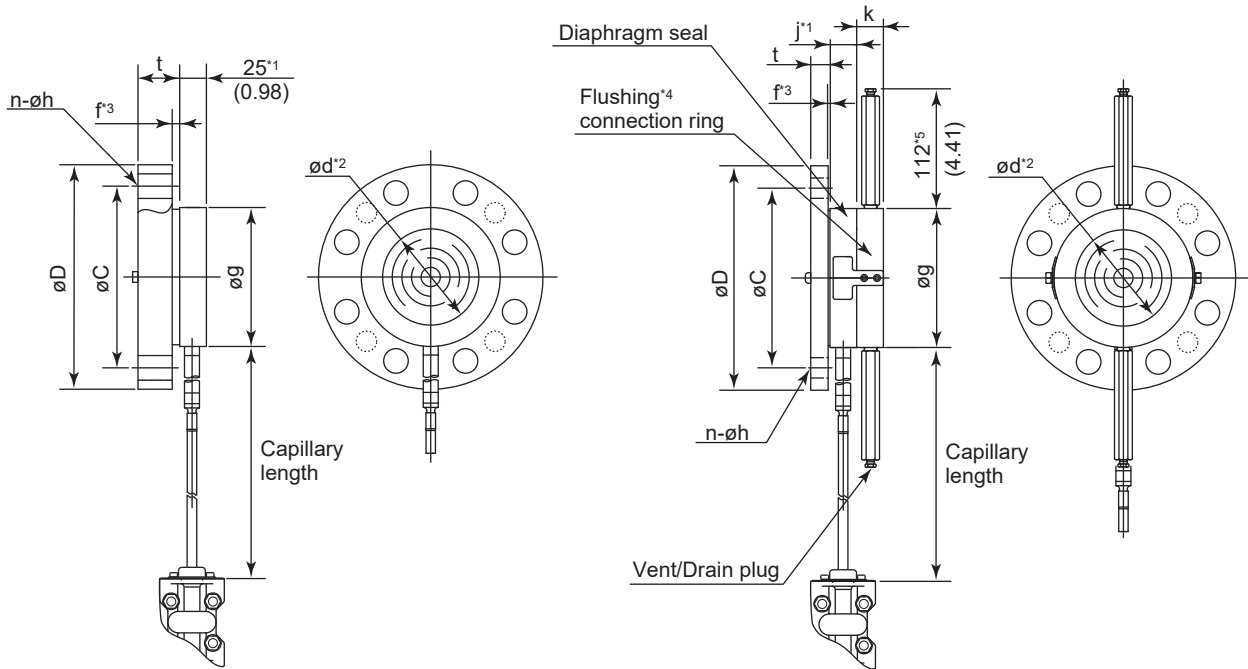

• Extended type

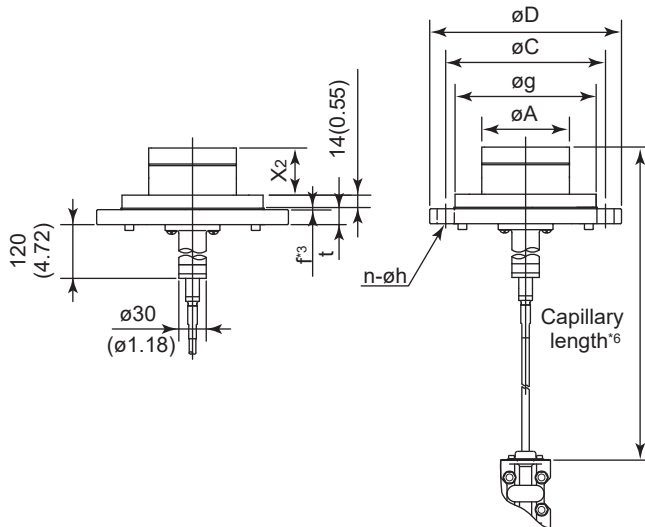

- *1: When wetted parts material code UW (titanium), value is 34 (1.34).
- *2: Indicates inside diameter of gasket contact surface.
- *3: In case where process flange material is JIS S25C, value of f is 0.

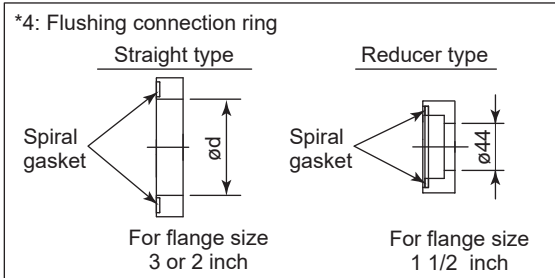

- *5: When option code K1 or K5 is selected, add 11 mm (0.28 inch.)
- *6: The specified capillary length includes the extension length (X₂) and the flange thickness (t).

• Extension length (X2)

Extension code	X2
1	50 (1.97)
3	100 (3.94)
5	150 (5.91)

F10E.ai

Unit: mm (approx.inch)

Process flange size: 4 inch (100 mm)

Code	Flange rating	øD	øC	øg	ød	t	f ³	Bolt holes		j	k	øA
								No.(n)	Dia.(øh)			
J1	JIS 10K	210 (8.27)	175 (6.89)	155 (6.10)	—	18 (0.71)	0	8	19 (0.75)	—	—	96±0.5 (3.78±0.02)
J2	JIS 20K	225 (8.86)	185 (7.28)	155 (6.10)	—	24 (0.94)	0	8	23 (0.91)	—	—	96±0.5 (3.78±0.02)
J4	JIS 40K	250 (9.84)	205 (8.07)	155 (6.10)	—	36 (1.42)	0	8	25 (0.98)	—	—	96±0.5 (3.78±0.02)
A1	ANSI class 150	228.6 (9.00)	190.5 (7.50)	155 (6.10)	—	23.9 (0.94)	1.6 (0.06)	8	19.1 (0.75)	—	—	96±0.5 (3.78±0.02)
A2	ANSI class 300	254 (10.00)	200.2 (7.88)	155 (6.10)	—	31.8 (1.25)	1.6 (0.06)	8	22.4 (0.88)	—	—	96±0.5 (3.78±0.02)
P1	JPI class 150	229 (9.02)	190.5 (7.50)	155 (6.10)	—	24 (0.94)	1.6 (0.06)	8	19 (0.75)	—	—	96±0.5 (3.78±0.02)
P2	JPI class 300	254 (10.0)	200.2 (7.88)	155 (6.10)	—	32 (1.26)	1.6 (0.06)	8	22 (0.87)	—	—	96±0.5 (3.78±0.02)
D2	DIN PN10/16	220 (8.66)	180 (7.09)	155 (6.10)	—	20 (0.79)	0	8	18 (0.71)	—	—	96±0.5 (3.78±0.02)
D4	DIN PN25/40	235 (9.25)	190 (7.48)	155 (6.10)	—	24 (0.94)	0	8	22 (0.87)	—	—	96±0.5 (3.78±0.02)

Process flange size: 3 inch (80 mm)

Code	Flange rating	øD	øC	øg	ød ²	t	f ³	Bolt holes		j ^{*1}	k	øA
								No.(n)	Dia.(øh)			
J1	JIS 10K	185 (7.28)	150 (5.91)	130 (5.12)	90 (3.54)	18 (0.71)	0	8	19 (0.75)	25 (0.98)	27 (1.06)	71±0.5 (2.8±0.02)
J2	JIS 20K	200 (7.87)	160 (6.30)	130 (5.12)	90 (3.54)	22 (0.87)	0	8	23 (0.91)	25 (0.98)	27 (1.06)	71±0.5 (2.8±0.02)
J4	JIS 40K	210 (8.27)	170 (6.69)	130 (5.12)	90 (3.54)	32 (1.26)	0	8	23 (0.91)	25 (0.98)	27 (1.06)	—
J6	JIS 63K	230 (9.06)	185 (7.28)	130 (5.12)	90 (3.54)	40 (1.57)	0	8	25 (0.98)	25 (0.98)	27 (1.06)	71±0.5 (2.8±0.02)
A1	ANSI class 150	190.5 (7.50)	152.4 (6.00)	130 (5.12)	90 (3.54)	23.9 (0.94)	1.6 (0.06)	4	19.1 (0.75)	25 (0.98)	27 (1.06)	71±0.5 (2.8±0.02)
A2	ANSI class 300	209.6 (8.25)	168.1 (6.62)	130 (5.12)	90 (3.54)	28.5 (1.12)	1.6 (0.06)	8	22.4 (0.88)	25 (0.98)	27 (1.06)	71±0.5 (2.8±0.02)
A4	ANSI class 600	209.6 (8.25)	168.1 (6.62)	130 (5.12)	90 (3.54)	38.2 (1.50)	6.4 (0.25)	8	22.4 (0.88)	25 (0.98)	27 (1.06)	—
P1	JPI class 150	190 (7.48)	152.4 (6.00)	130 (5.12)	90 (3.54)	24 (0.94)	1.6 (0.06)	4	19 (0.75)	25 (0.98)	27 (1.06)	71±0.5 (2.8±0.02)
P2	JPI class 300	210 (8.27)	168.1 (6.61)	130 (5.12)	90 (3.54)	28.5 (1.12)	1.6 (0.06)	8	22 (0.87)	25 (0.98)	27 (1.06)	71±0.5 (2.8±0.02)
P4	JPI class 600	210 (8.27)	168.1 (6.61)	130 (5.12)	90 (3.54)	38.4 (1.51)	6.4 (0.25)	8	22 (0.87)	25 (0.98)	27 (1.06)	—
D2	DIN PN10/16	200 (7.87)	160 (6.30)	130 (5.12)	90 (3.54)	20 (0.79)	0	8	18 (0.71)	25 (0.98)	27 (1.06)	71±0.5 (2.8±0.02)
D4	DIN PN25/40	200 (7.87)	160 (6.30)	130 (5.12)	90 (3.54)	24 (0.94)	0	8	18 (0.71)	25 (0.98)	27 (1.06)	71±0.5 (2.8±0.02)
D5	DIN PN64	215 (8.46)	170 (6.69)	130 (5.12)	90 (3.54)	28 (1.10)	0	8	22 (0.87)	25 (0.98)	27 (1.06)	—

Unit: mm (approx.inch)

Process flange size: 2 inch (50 mm)

Code	Flange rating	øD	øC	øg	ød ²	t	f ³	Bolt holes		j ¹	k
								No.(n)	Dia.(øh)		
J1	JIS 10K	155 (6.10)	120 (4.72)	100 (3.94)	61 (2.40)	16 (0.63)	0	4	19 (0.75)	25 (0.98)	27 (1.06)
J2	JIS 20K	155 (6.10)	120 (4.72)	100 (3.94)	61 (2.40)	18 (0.71)	0	8	19 (0.75)	25 (0.98)	27 (1.06)
J4	JIS 40K	165 (6.50)	130 (5.12)	100 (3.94)	61 (2.40)	26 (1.02)	0	8	19 (0.75)	25 (0.98)	27 (1.06)
J6	JIS 63K	185 (7.28)	145 (5.71)	100 (3.94)	61 (2.40)	34 (1.34)	0	8	23 (0.91)	25 (0.98)	27 (1.06)
A1	ANSI class 150	152.4 (6.00)	120.7 (4.75)	100 (3.94)	61 (2.40)	19.1 (0.75)	1.6 (0.06)	4	19.1 (0.75)	25 (0.98)	27 (1.06)
A2	ANSI class 300	165.1 (6.50)	127.0 (5.00)	100 (3.94)	61 (2.40)	22.4 (0.88)	1.6 (0.06)	8	19.1 (0.75)	25 (0.98)	27 (1.06)
A4	ANSI class 600	165.1 (6.50)	127.0 (5.00)	100 (3.94)	61 (2.40)	31.8 (1.25)	6.4 (0.25)	8	19.1 (0.75)	25 (0.98)	27 (1.06)
P1	JPI class 150	152 (5.98)	120.6 (4.75)	100 (3.94)	61 (2.40)	19.5 (0.77)	1.6 (0.06)	4	19 (0.75)	25 (0.98)	27 (1.06)
P2	JPI class 300	165 (6.50)	127.0 (5.00)	100 (3.94)	61 (2.40)	22.4 (0.88)	1.6 (0.06)	8	19 (0.75)	25 (0.98)	27 (1.06)
P4	JPI class 600	165 (6.50)	127.0 (5.00)	100 (3.94)	61 (2.40)	31.9 (1.26)	6.4 (0.25)	8	19 (0.75)	25 (0.98)	27 (1.06)
D2	DIN PN10/16	165 (6.50)	125 (4.92)	100 (3.94)	61 (2.40)	18 (0.71)	0	4	18 (0.71)	25 (0.98)	27 (1.06)
D4	DIN PN25/40	165 (6.50)	125 (4.92)	100 (3.94)	61 (2.40)	20 (0.79)	0	4	18 (0.71)	25 (0.98)	27 (1.06)
D5	DIN PN64	180 (7.09)	135 (5.31)	100 (3.94)	61 (2.40)	26 (1.02)	0	4	22 (0.87)	25 (0.98)	27 (1.06)

Process flange size: 1 1/2 inch (40 mm)

Code	Flange rating	øD	øC	øg	ød ²	t	f ³	Bolt holes		j	k
								No.(n)	Dia.(øh)		
J1	JIS 10K	140 (5.51)	105 (4.13)	86 (3.39)	44 (1.73)	16 (0.63)	0	4	19 (0.75)	27 (1.06)	30 (1.18)
J2	JIS 20K	140 (5.51)	105 (4.13)	86 (3.39)	44 (1.73)	18 (0.71)	0	4	19 (0.75)	27 (1.06)	30 (1.18)
J4	JIS 40K	160 (6.30)	120 (4.72)	86 (3.39)	44 (1.73)	24 (0.94)	0	4	23 (0.91)	27 (1.06)	30 (1.18)
A1	ANSI class 150	127 (5.00)	98.6 (3.88)	86 (3.39)	44 (1.73)	17.5 (0.69)	1.6 (0.06)	4	15.9 (0.63)	27 (1.06)	30 (1.18)
A2	ANSI class 300	155.4 (6.12)	114.3 (4.50)	86 (3.39)	44 (1.73)	20.6 (0.81)	1.6 (0.06)	4	22.4 (0.88)	27 (1.06)	30 (1.18)
A4	ANSI class 600	155.4 (6.12)	114.3 (4.50)	86 (3.39)	44 (1.73)	28.8 (1.13)	6.4 (0.25)	4	22.4 (0.88)	27 (1.06)	30 (1.18)
P1	JPI class 150	127 (5.00)	98.6 (3.88)	86 (3.39)	44 (1.73)	17.6 (0.69)	1.6 (0.06)	4	16 (0.63)	27 (1.06)	30 (1.18)
P2	JPI class 300	155 (6.10)	114.3 (4.50)	86 (3.39)	44 (1.73)	20.6 (0.81)	1.6 (0.06)	4	22 (0.87)	27 (1.06)	30 (1.18)
P4	JPI class 600	155 (6.10)	114.3 (4.50)	86 (3.39)	44 (1.73)	28.9 (1.14)	6.4 (0.25)	4	22 (0.87)	27 (1.06)	30 (1.18)

*1: When wetted parts material code UW (titanium) is selected, value is 34 (1.34.)

*2: Indicates inside diameter of gasket contact surface.

*3: In case where process flange material is JIS S25C, value of f is 0.

< Ordering Information > “◇”

Specify the following when ordering

1. Model, suffix codes, and option codes
2. Calibration range and units:
 - 1) Calibration range can be specified with range value specifications up to 5 digits (excluding any decimal point) for low or high range limits within the range of -32000 to 32000. When reverse range is designated, specify LRV as greater than URV.
 - 2) Specify only one unit from the table, 'Factory setting.'
3. Display scale and units (for transmitters equipped with the integral indicator only)

Specify either 0 to 100 % or 'Range and Unit' for engineering units scale:

Scale range can be specified with range limit specifications up to 5 digits (excluding any decimal point) for low or high range limits within the range of -32000 to 32000. Unit display consists of 6-digit, therefore, if the specified scaling unit excluding '/' is longer than 6-characters, the first 6 characters will be displayed on the unit display.
4. HART PROTOCOL

When output signal code is "J", specify the HART protocol revision "5" or "7".
5. TAG NO (if required)

Specified characters (up to 16 characters for BRAIN, 22 characters for HART, or 16 characters for /N4 tag) are engraved on the stainless steel tag plate fixed on the housing.
6. SOFTWARE TAG (for HART only, if required)

Specified characters (up to 32 characters) are set as "Tag" (the first 8 characters) and "Long tag"^{*1} (32 characters) in the amplifier memory. Use alphanumeric capital letters.

When the "SOFTWARE TAG" is not specified, specified "TAG NO" is set as "Tag" (the first 8 characters) and "Long tag"^{*1} (22 characters) in the amplifier memory.

^{*1}: applicable only when HART 7 is selected.
7. Other factory configurations (if required)

Specifying option code **CA** or **CB** will allow further configuration at factory. Following are configurable items and setting range.

[/CA : For HART communication type]

 - 1) Descriptor (up to 16 characters)
 - 2) Message (up to 30 characters)
 - 3) Software damping (0.00 to 100.00 s)

[/CB : For BRAIN communication type]

 - 1) Software damping (0.00 to 100.00 s)
8. Process fluid temperature for zero compensation (When /R is specified.)

< Factory Setting > “◇”

Tag number	As specified in order
Software damping ^{*1}	'2.00 s' or as specified in order
Calibration range lower range value	As specified in order
Calibration range upper range value	As specified in order
Calibration range units	Selected from mmH ₂ O, mmH ₂ O(68°F), mmAq ^{*2} , mmWG ^{*2} , mmHg, Pa, hPa ^{*2} , kPa, MPa, mbar, bar, gf/cm ² , kgf/cm ² , inH ₂ O, inH ₂ O(68°F), inHg, ftH ₂ O, ftH ₂ O(68°F) or psi. (Only one unit can be specified.)
Display setting	Designated value specified in order, absolute value. (% or user scaled value.)

^{*1}: To specify these items at factory, /CA or /CB option is required.
^{*2}: Not available for HART protocol type.

< Material Cross Reference >

ASTM	JIS
316	SUS316
F316	SUSF316
316L	SUS316L
F316L	SUSF316L
304	SUS304
F304	SUSF304
660	SUH660
B7	SNB7
CF-8M	SCS14A

<Information on EU WEEE Directive>

EU WEEE (Waste Electrical and Electronic Equipment) Directive is only valid in the EU.

This instrument is intended to be sold and used only as a part of equipment which is excluded from WEEE Directive, such as large-scale stationary industrial tools, a large-scale fixed installation and so on, and, therefore, subjected to the exclusion from the scope of the WEEE Directive. The instrument should be disposed of in accordance with local and national legislation/regulations.