

Excel 50 CONTROLLER

HONEYWELL EXCEL 5000 OPEN SYSTEM

SPECIFICATION DATA



FEATURES

- **Various state-of-the-art communication options:** Open LONWORKS® bus, Meter-bus, or C-bus communication; modem or ISDN terminal adapter at up to 38.4 Kbaud
- **Unique features in open LONWORKS® networks:** NV-Booster® reduces the number of required NVs and thus also the number of required controllers; NV bindings can be restored after controller reset (and thus need not be redone after exchanging controllers); 46 NVs supported for LONWORKS® integration
- **Reduced engineering and start-up costs:** Huge variety of pre-tested and fully documented applications
- **Easy and flexible installation:** Screw terminals; mounting inside cabinet (DIN rail) or in cabinet front door
- **Operating options:** Integrated operator interface, XI582 Remote Interface, XI882 Remote Touch-Panel Interface, and XL-Online PC-based interface

GENERAL

The Excel 50 controller has built-in communication capability, allowing it to be integrated into a Honeywell EXCEL 5000® System or into an open LONWORKS® network communicating with Excel 10 controllers as room/zone controllers or with 3rd-party products. It can also serve as a stand-alone controller. Typical areas of application include heating systems, district heating systems, and air conditioning plants for restaurants, shops, offices, and small branch government buildings.

The Excel 50 supports standard LonMark™ Network Variables according to the LonMark™ Interoperability Guidelines V.3.0. It can serve 22 integrated I/Os and supports peer-to-peer communication; thus, in the case of larger-scale applications, several different controllers can be linked and accessed. The system firmware is stored in Flash EPROM located in the application module (a separate module plugged into the controller housing.) Flash EPROM allows easy upgrading of the operating system via download.

The Excel 50 is a freely programmable controller engineered using Honeywell's CARE programming tool. For LONWORKS® interoperability, a maximum of 46 LonMark™ NVs are available.

DESCRIPTION

The Excel 50 controller is available in two housing versions, one with and one without a Man-Machine-Interface (MMI.) The MMI version allows buswide access to other controllers. The XI582 operator interface or the PC-based XL-Online operator and service software can be used in conjunction with either version. The housing can be mounted inside a cabinet on a DIN-rail or in a cabinet front door.

The Excel 50 has eight analog inputs, four analog outputs, four digital inputs (three of which can be used as totalizers,) and six digital outputs. The digital outputs allow the direct drive of 3-position actuators (up to the max. load.) The controller can be wired either with screw terminal blocks directly at the housing.) Pre-wiring is possible in both cases, and a controller can be replaced without rewiring.

The application modules – all with Flash EPROM – are available in seven bus-wide access versions and two stand-alone versions. They feature a variety of bus interfaces (see Table 1.) Large RAMs provide for increased trending capability. A modem or ISDN terminal adapter can be connected to the serial port to allow remote access at up to 38.4 Kbaud.

All changeable parts or switches are accessible without opening the housing. Communication capabilities and memory are easily upgraded by replacing application modules.

SPECIFICATIONS

Versions

Housing

- XL50A-MMI and XL50A-CY (with Man-Machine Interface);
- XL50A (without MMI.)

Versions with MMI

Both the XL50A-MMI and the XL50A-CY feature a keypad (with eight function keys and four fast-access keys) and an LCD display.

- The LCD display of the XL50A-MMI has four lines, 16 characters per line, adjustable contrast, and backlight.
- The LCD display of the XL50A-CY features 128 X 64 dot graphics, adjustable contrast, and backlight.

Application Modules

The Excel 50 controller can be upgraded by direct firmware download via serial port or C-Bus. Contact your local Honeywell affiliate for more information on the available firmware and applications.

Table 1. Module versions

module	description
XD50B-F	Stand-alone; 2 MB Flash EPROM; 256 KB RAM; European and Chinese language support
XD50B-F-TW	Stand-alone; 2 MB Flash EPROM; 256 KB RAM; Taiwanese language support
XD50B-FC	Bus-wide access via C-Bus; 2 MB Flash EPROM; 256 KB RAM; European and Chinese language support
XD50B-FL	Bus-wide access via LONWORKS® Bus; 2 MB Flash EPROM; 256 KB RAM; European and Chinese language support
XD50B-FCL	Bus-wide access via C-Bus / LONWORKS® Bus; 2 MB Flash EPROM; 256 KB RAM; European and Chinese language support
XD50B-FL-TW	Bus-wide access via LONWORKS® Bus; 2 MB Flash EPROM; 256 KB RAM; Taiwanese language support
XD50B-FCL-TW	Bus-wide access via C-Bus / LONWORKS® Bus; 2 MB Flash EPROM; 256 KB RAM; Taiwanese language support
XD50-FCS	Bus-wide access via C-Bus / Meter-Bus; 1 MB Flash EPROM; 256 KB RAM
XD50-FLS	Bus-wide access via LONWORKS® / Meter-Bus; 2 MB Flash EPROM; 256 KB RAM

Mounting Options

Front door mounted with sealing ring.

Cabinet mounted on DIN-rail (rail clips shipped with device.)

I/O Terminal Connection

Screw terminal blocks directly attached to housing.

Power Supply

Voltage

24 Vac, $\pm 20\%$, 50/60 Hz from external transformer.

Current

3 A (2 A if digital output current ≤ 1.5 A.) In case of power failure, the super gold capacitor saves RAM content and real-time clock for 72 hours (thus, no battery disposal necessary.)

Power Consumption

Max. 10 VA without load at digital outputs.

Input/Output Specifications

type	characteristics
eight analog inputs (universal)	Voltage: 0...10 V (software-controlled switches for high impedance) Current: 0...20 mA (via external 499 Ω resistor) Resolution: 10-bit Sensor: NTC 20k Ω , -58...+302 °F (-50...150 °C)
four digital inputs	Voltage: max. 24 Vdc (≤ 2.5 V = logical status of 0, ≥ 5 V = logical status of 1.) 0...0.4 Hz (0...15 Hz for three of four inputs when used as totalizer, 4 th input only for static parameter requirements)
four analog outputs (universal)	Voltage: 0...10 V, max. 11 V, ± 1 mA Resolution: 8-bit Relay: via MCE3 or MCD3
six digital outputs	Voltage: 24 Vac per triac Current: max. 0.8 A, 2.4 A for all six triacs together

All inputs and outputs protected against overvoltage up to 24 Vac and 35 Vdc. Digital outputs protected against short circuits via a changeable fuse (built-in fuse, 5 x 20 mm, 4 A quick-blow.)

Bus and Port Connections

C-Bus Connection

Optional; located on application module. Up to 76.8 Kbaud, switch provided for selectable termination.

LONWORKS® Bus Connection

Optional; located on application module. 78 Kbaud, FTT-10A Free Topology Transceiver, using LonTalk® protocol.

Controller Serial Port Connection

9-pin Sub-D connector, RS 232, 9.6 Kbaud for XI582, XL-Online, or up to 38.4 Kbaud for modem/ISDN terminal adapter connection.

Meter-Bus Connection

Optional; located on application module. RS232 serial link with RJ45 connector (PW3 Meter-Bus adapter also required.)

I/O Connectors

I/O Connector A: 26-pin port, digital outputs and power.

I/O Connector B: 34-pin port, analog and digital inputs, analog outputs.

Environmental Ratings

Operating temperature: 0...50 °C (+32...+122°F)

Storage temperature: -20...+70 °C (-4...+158°F)

Relative humidity: 5...93% non-condensing

Protection Standards

IP54 (when front-door mounted with MMI in a cabinet conforming to IP54 and use of ACC3 mounting clamps and sealing ring.)

IP20 (when wall-mounted: both with and without MMI.)

UL94-0: Flame-retardant class of housing material.

Certifications

- CE
- UL 916 and cUL
- Meets FCC Part 15, Subpart J for Class A equipment.

Application Module

Firmware

The firmware is downloadable via the PC-based XL-Online operator and service software or C-Bus.

NOTE: The application module firmware version should be equal to or greater than 2.07.00.

Housing

Plug-in plastic module, wired with screws.

Application Module LEDs and Ports

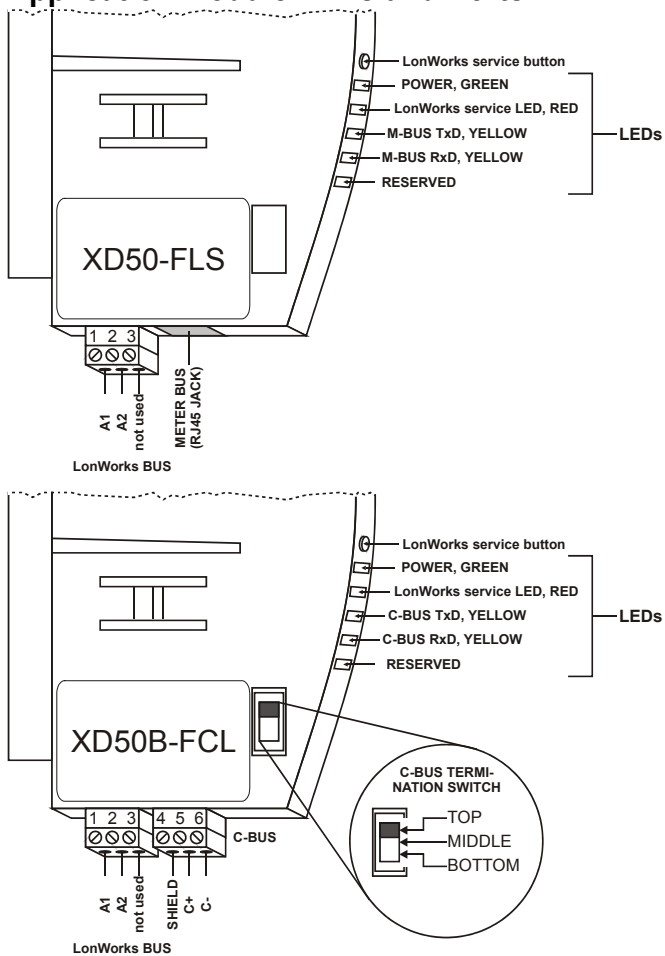

Fig. 1. Application modules (examples)

Terminal Blocks

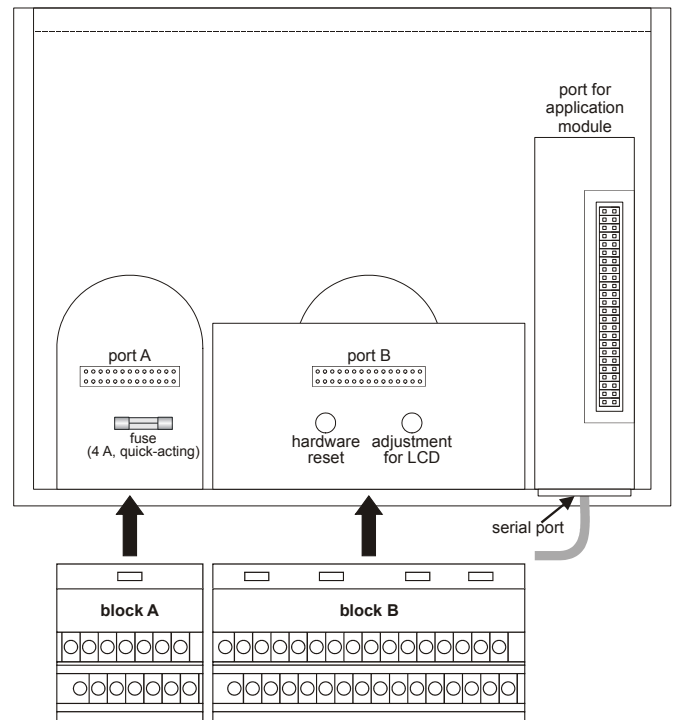

Fig. 2. Removable screw terminal blocks

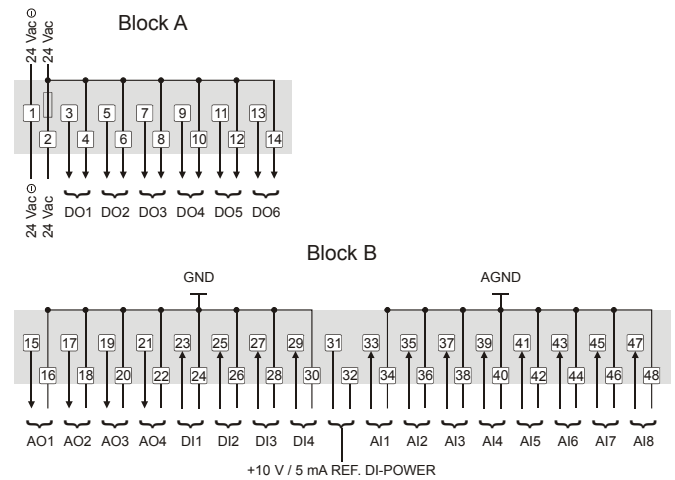
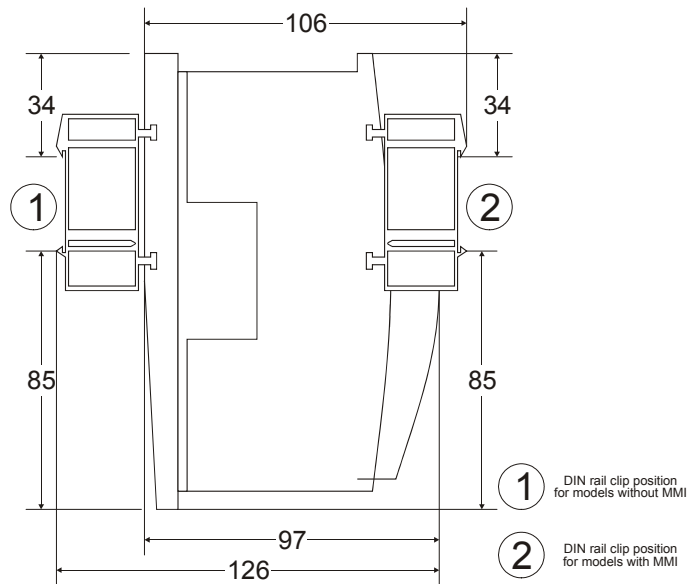
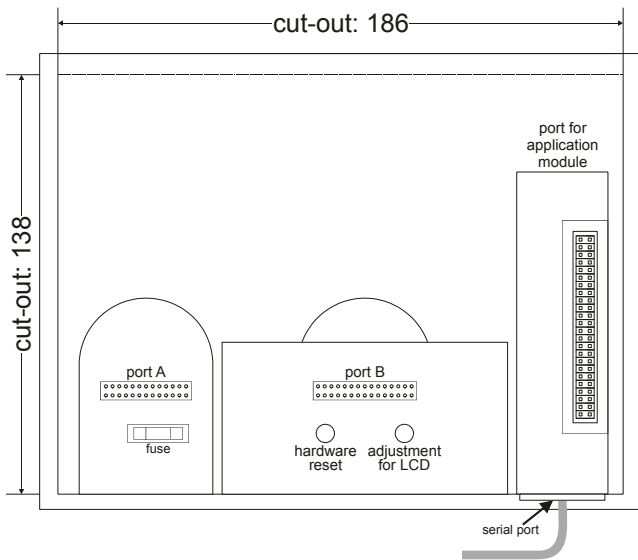
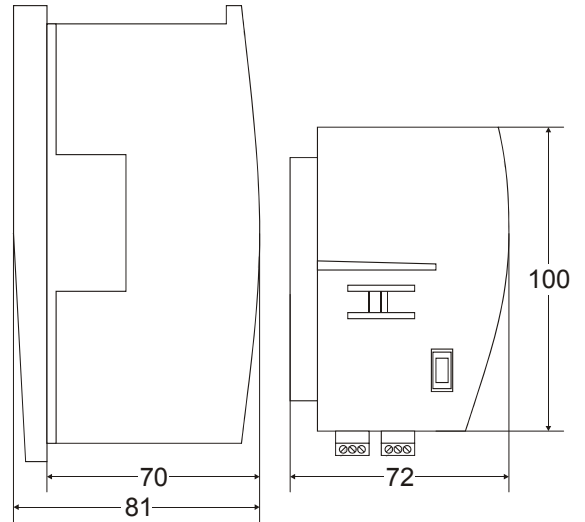
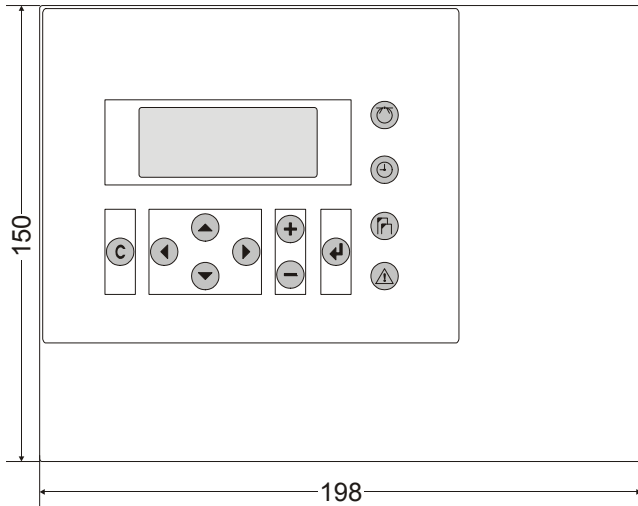

Fig. 3. Terminal assignment of screw terminal blocks

Dimensions



Honeywell

Manufactured for and on behalf of the Environmental and Combustion Controls Division of Honeywell Technologies Sàrl, Rolle, Z.A. La Pièce 16, Switzerland by its Authorized Representative:

Automation and Control Solutions

Honeywell GmbH
 Böblinger Strasse 17
 71101 Schönaich, Germany
 Phone: (49) 7031 63701
 Fax: (49) 7031 637493
<http://ecc.emea.honeywell.com>
 Subject to change without notice. Printed in Germany

EN0B-0088GE51 R0910