

ifm electronic

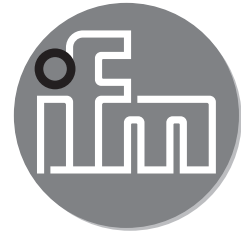

Installation instructions

AS interface

AS-i CONTROLLER_e

AC1305/AC1306

UK

7390412 / 00 03 / 2005

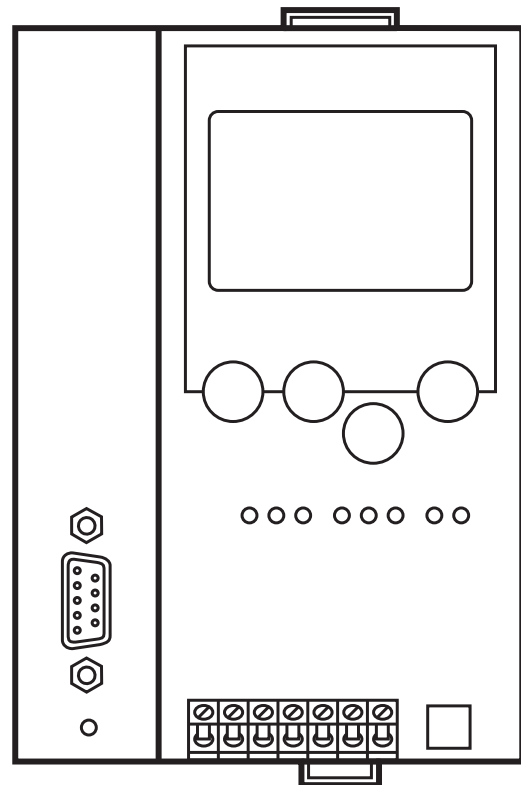

Contents

Functions and features	3
Programming interface RS232C.....	3
Profibus DP interface.....	3
Installation	3
Electrical connection.....	4
Operating and display elements	4
LED indicators and pin connection	5
Contrast setting	6
Operation.....	6
Menu overview	7
Menu navigation	8

Functions and features

- The controller_e integrates one or two AS-i masters (AC1305/AC1306, both in accordance with the AS-i version 2.1), a mini controller and a Profibus DP interface (optional).
- It controls the exchange of data to the sensor / actuator level,
- processes the peripheral data in the integrated processor (signal preprocessing),
- works as stand-alone controller with exchange of data to the PC (visualisation),
- communicates with the higher control level (in the gateway mode).

UK

Programming interface RS232C

- Baud rate 4800 to 115,200 baud
- Max. distance between controller_e and host: 20 m
- Potential separation from the controller_e power supply
- Programming cable E70320 for connection to host required

Profibus DP interface

- Baud rate 9600 baud to 12 Mbaud
- Max. distance between controller_e and host: depending on the baud rate
- Potential separation from the controller_e power supply
- Up to 31 controllers connected in parallel per segment
- Pin connection: pin 3: signal B, pin 8: signal A

Installation

Fix the controller_e onto a 35 mm rail. The protection rating of the unit is IP 20, therefore it should be mounted in a protected location (e.g. control cabinet).



Ensure a condensation-free environment. Avoid excessive dust, vibration and shock. The air circulation through the vents must not be impeded.

Avoid installation in direct vicinity of frequency inverters.

Electrical connection



Disconnect the installation from power. Connect the unit as indicated on the terminals. Never connect the minus potentials to each other or the minus potentials to the FE connection. Ensure an electrically safe ground connection between AS-i controller_e (terminal FE) and ground of the unit.

Supply the controller_e with a 24 V DC voltage (20 ... 30 V PELV), e.g. from the 24 V power supply DN2011 from ifm electronic. The connection is made to the terminals +24 V and 0 V.

Operating and display elements

Information concerning the state of the master (AC1305) / masters (AC1306) and the connected system is given via three diagnostic LEDs on the controller_e.

LED PWR/COM lights:	AS-i voltage present, at least one slave was detected
LED PWR/COM flashes:	AS-i voltage present, but no slave was detected correctly
LED PROJ lights:	Projection mode active, the configuration monitoring is deactivated
LED PROJ flashes:	Projection mode active, changeover to protected mode not possible as a slave with the address 0 is connected
LED CONF/PF lights:	Projected and current configuration do not match
LED CONF/PF flashes:	Peripheral fault on at least one connected slave
LED PROFIBUS lights:	Bus error Profibus DP

LED indicators and pin connection

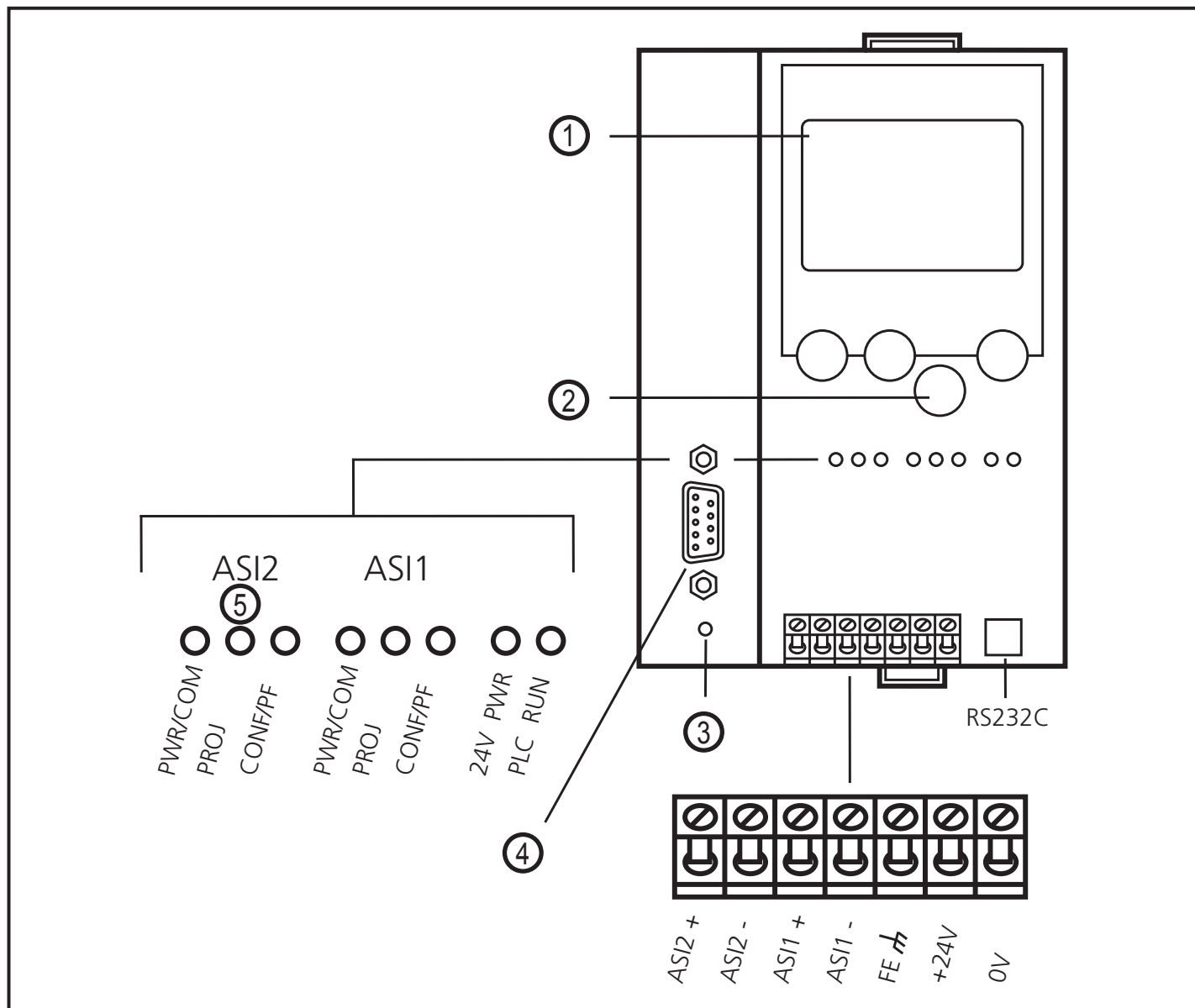

UK

- 1: Display
- 2: Pushbuttons
- 3: Profibus DP bus error
- 4: Profibus DP interface
- 5: Only AC1306

Contrast setting

The contrast can be directly changed by simultaneously pressing the right button and the Δ -button (too bright) or the ∇ -button (too dark).

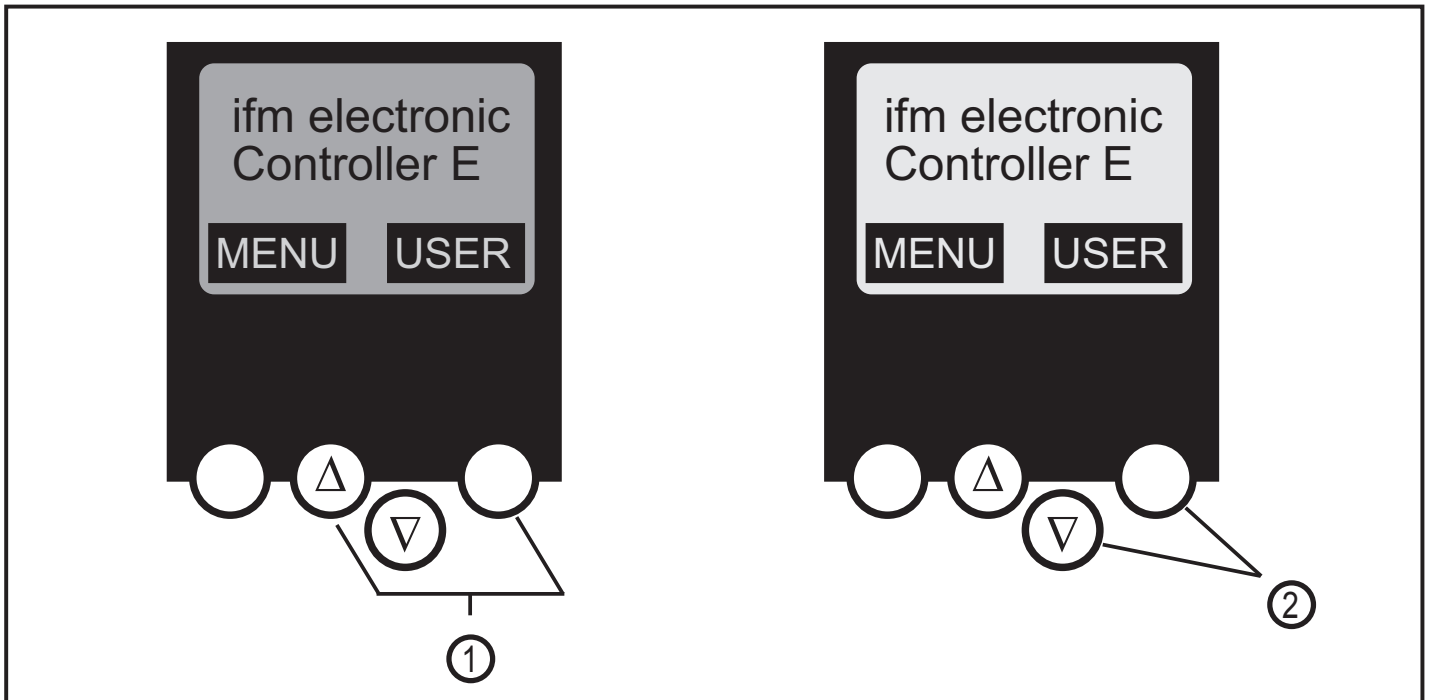

- 1: Increase contrast
- 2: Decrease contrast

Operation

To operate an AS-i system a special AS-i power supply is required (e.g. AC1216). The AS-i power supply supplies the yellow AS-i cable with energy and implements a data decoupling to the voltage regulator of the power supply. Standard switched-mode power supplies would consider the AS-i data signals as interference signals and suppress them.



Disconnect the power supply before connecting the controller_e.



The AS-i system is operated ungrounded. AS-i + and AS-i - are to be symmetrical to the ground potential of the installation. Ensure a low-resistance connection of the symmetry point of the AS-i power supply (terminal "shield") to the ground of the installation.

Menu overview

Open the main menu by pressing the left button "MENU" in the start display.

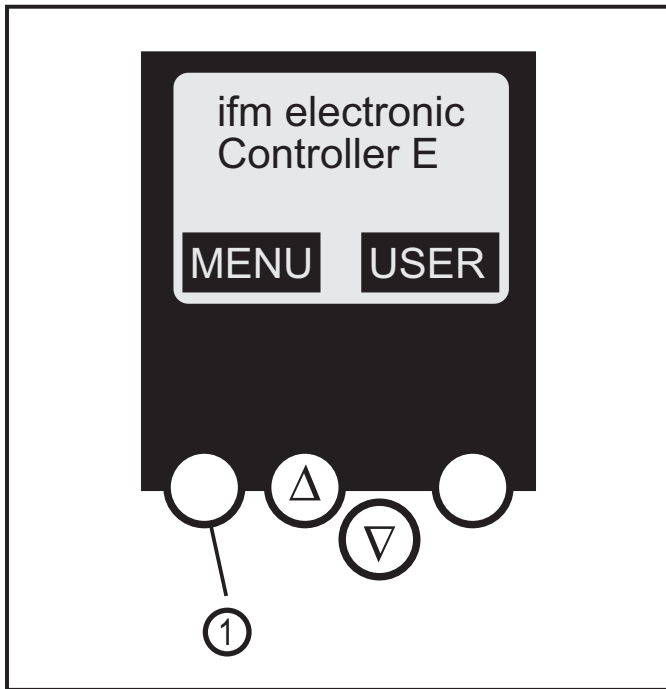

- 1: Menu button
- 2: Navigation buttons

To navigate within a menu point press the button Δ or ∇ .

Press the buttons simultaneously to switch between the German and English menu.

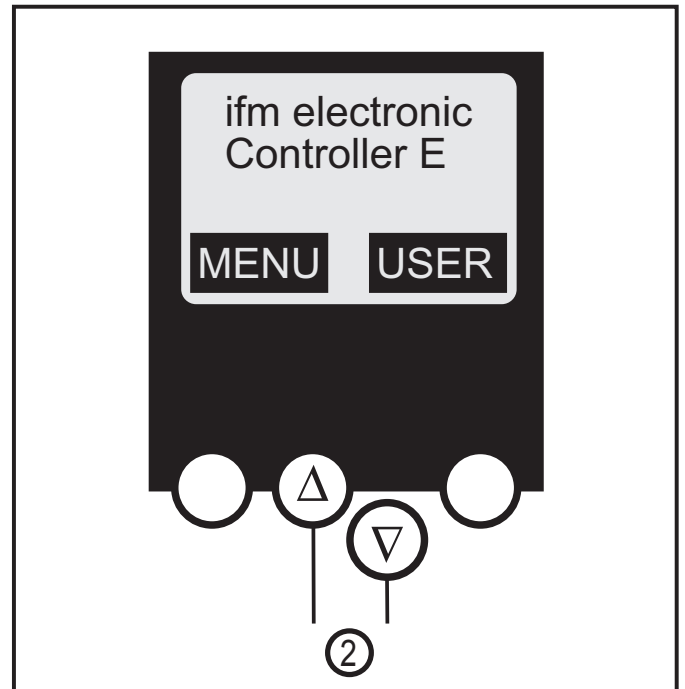

UK

Menu navigation

O Slave Lists	<p>(Checking of the addresses of the connected AS-i slaves)</p> <ul style="list-style-type: none"> • List of the detected AS-i slaves (LDS) • List of the projected AS-i slaves (LPS) • List of the activated AS-i slaves (LAS) • List of the AS-i slaves with peripheral fault (LPF)
O Address Slave	<p>(Programming of the correct addresses in the connected AS-i slaves)</p> <ul style="list-style-type: none"> • Readdressing of an AS-i slave connected to the controller_e • Automatic addressing of new AS-i slaves to the next free address (Easy Start-up)
O Quick Setup	<p>(Summary of the menu points required for a basic configuration)</p> <ul style="list-style-type: none"> • Reading of the current AS-i configuration (config all) • Setting of the fieldbus connection (optional)
O System Setup	<p>(Setting of the controller_e device)</p> <ul style="list-style-type: none"> • Baud rate of the serial programming interface • IP address of the Ethernet programming interface (optional) • Input of the password to enable changes in the system configuration • Update of the controller_e firmware (special programming software required)
O System Info	<p>(Device information)</p> <ul style="list-style-type: none"> • Hardware and firmware version numbers of this controller_e • Serial number of this controller_e • Current / maximum PLC cycle time

O PLC Setup	(Using the integrated PLC is optional) <ul style="list-style-type: none"> • Activation or deactivation of the gateway mode (no PLC used) • Start or stop of the PLC in the controller_e (if used)
O PLC Info	(Display of the user program name, author, date)
O Master Setup	(AS-i master flags) <ul style="list-style-type: none"> • Reading of the current AS-i configuration (config all) • Changeover to the projection mode: configuration of the AS-i system • Changeover to the protected mode: standard mode (the master monitors the configuration) • Deactivation of the automatic AS-i slaves addressing in the protected mode • Deactivation of the AS-i reset when exiting the projection mode • Display of the config error counter of the connected AS-i system • Reset of the config error counter • Display of the fault rate percentage of the connected AS-i system
O Slave Setup	(Details about the connected AS-i slaves) <ul style="list-style-type: none"> • Digital or analogue inputs / outputs of the connected AS-i slaves • Current and projected parameters of the connected AS-i slaves • Current and projected I/O and I/D codes of the connected AS-i slaves • Message faults in the communication to the connected AS-i slaves

O Fieldbus Setup	(The different fieldbus interfaces are optional) Input of the slave address of the controller _e in the higher-level fieldbus Further inputs depending on the higher-level fieldbus
O Fieldbus Data	(Optional) Display of the data cyclically transmitted via the fieldbus