

ifm electronic



Installation instructions
ExtendedController
ISOBUS

UK

ecomat100[®]

CR0253

80255279 / 00 06 / 2016

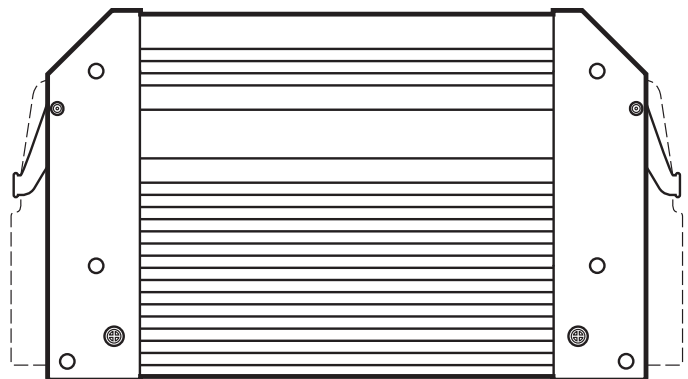

Contents

1	Preliminary note	4
1.1	Symbols used	4
1.2	Warning signs used	4
2	Safety instructions	5
2.1	General	5
2.2	Target group	5
2.3	Electrical connection	5
2.4	Housing temperature	5
2.5	Tampering with the device	6
2.6	Electromagnetic compatibility	6
2.7	Electrical welding on vehicles and plants	6
3	Functions and features	6
4	Installation	7
4.1	Fastening	7
4.2	Installation position	7
4.3	Mounting surface	8
4.4	Heat dissipation	8
5	Electrical connection	9
5.1	Wiring	9
5.1.1	Assignment of the connectors	9
5.2	Ground connection	9
5.3	Fuses	10
5.4	Laying the supply and signal cables	10
5.4.1	GND connections of the Ex connection side	11
5.5	Frequency and analogue inputs	11
5.6	Resistor inputs	12
5.6.1	Unused input I15	12
5.7	Supply low-side digital outputs (B _L)	13
5.8	Connection technology	13
5.9	USB interface	14
5.9.1	Hardware requirement	14
5.9.2	Short-circuit protection	14
6	Set-up	15
6.1	Documentation	15
6.1.1	ISOBUS documentation	15
6.2	Interfaces and system requirements	15
6.3	Communication via USB interface	15
6.4	Install the USB drivers	16
6.5	Uninstall the drivers	16
7	Technical data	17
7.1	Mechanical and electric data	17

7.2 Test standards and regulations	19
7.3 St side / input characteristics	20
7.4 St side / output characteristics	23
7.5 Ex side / input characteristics	25
7.6 Ex side / output characteristics	26
7.7 St side / wiring	28
7.8 Ex side / wiring	29
8 Maintenance, repair and disposal	30
9 Approvals/standards	30

1 Preliminary note

This document applies to devices of the type "ExtendedController" (art. no.: CR0253).



These instructions are an integral part of the device.

This document is intended for specialists. These specialists are people who are qualified by their appropriate training and their experience to see risks and to avoid possible hazards that may be caused during operation or maintenance of the device. The document contains information about the correct handling of the device.

Read this document before use to familiarise yourself with operating conditions, installation and operation. Keep this document during the entire duration of use of the device.

Adhere to the safety instructions.

1.1 Symbols used

- ▶ Instruction
- > Reaction, result
- [...] Designation of keys, buttons or indications
- Cross-reference
-  Important note
Non-compliance can result in malfunction or interference.
-  Information
Supplementary note

1.2 Warning signs used

WARNING

Warning of serious personal injury.
Death or serious irreversible injuries may result.

CAUTION

Warning of personal injury.
Slight reversible injuries may result.

NOTE

Warning of damage to property.

2 Safety instructions

2.1 General

These instructions are an integral part of the device. They contain texts and figures concerning the correct handling of the device and must be read before installation or use.

Observe the operating instructions. Non-observance of the instructions, operation which is not in accordance with use as prescribed below, wrong installation or incorrect handling can seriously affect the safety of operators and machinery.

UK

2.2 Target group

These instructions are intended for authorised persons according to the EMC and low-voltage directives. The device must only be installed, connected and put into operation by a qualified electrician.

2.3 Electrical connection

Disconnect the device externally before handling it. If necessary, also disconnect any independently supplied output load circuits.

If the device is not supplied by the mobile on-board system (12/24 V battery operation), it must be ensured that the external voltage is generated and supplied according to the criteria for safety extra-low voltage (SELV) as this voltage is supplied without further measures to the connected controller, the sensors and the actuators.

The wiring of all signals in connection with the SELV circuit of the device must also comply with the SELV criteria (safety extra-low voltage, safe electrical isolation from other electric circuits).

If the supplied SELV voltage is externally grounded (SELV becomes PELV), the responsibility lies with the user and the respective national installation regulations must be complied with. All statements in this document refer to the device the SELV voltage of which is not grounded.

The connection terminals may only be supplied with the signals indicated in the technical data and/or on the device label and only the approved accessories of ifm electronic may be connected.

2.4 Housing temperature

As described in the technical specifications below the device can be operated in a wide ambient temperature range. Because of the additional internal heating the housing walls can have high perceptible temperatures when touched in hot environments.

2.5 Tampering with the device

In case of malfunctions or uncertainties please contact the manufacturer. Any tampering with the device can seriously affect the safety of operators and machinery. This is not permitted and leads to the exclusion of any liability and warranty claims.

2.6 Electromagnetic compatibility

This is a class A product. It can cause radio interference in domestic areas. In this case the operator is requested to take appropriate measures.

2.7 Electrical welding on vehicles and plants

Welding work on the chassis frame must only be carried out by qualified persons.

Remove and cover the plus and minus terminals of the batteries.

Disconnect all contacts of the controller from the on-board system prior to welding on the vehicle or plant. Connect the earth terminal of the welding device directly to the part to be welded.

Do not touch the controller or electric cables with the welding electrode or the earth terminal of the welding device.

Protect the controller against weld slag.

3 Functions and features

The freely programmable controllers of the "ExtendedController" series are rated for use under difficult conditions (e.g. extended temperature range, strong vibration, intensive EMC interference).

They are suited for direct installation in machines in mobile and robust applications. Integrated hardware and software functions (operating system) offer high protection for the machine.

The controllers can be used as CANopen master.

WARNING

The "ExtendedController" series is not approved for safety tasks in the field of safety of persons.

WARNING

The user is responsible for the safe function of the application programs which he created himself. If necessary, he must additionally carry out an approval test by corresponding supervisory and test organisations according to the national regulations.

4 Installation

4.1 Fastening

- ▶ Fix the controller to a flat surface using 4 M5 screws.
Screw material: steel or stainless steel
Tightening torque: 8 \pm 2 Nm
- ▶ Connect the housing to GND (\rightarrow 5.2 Ground connection).

NOTE

Use screws with a low head to avoid that the connector is damaged when placed and locked.

UK

Screws to be used (examples)	Standard
Button head hexagon socket screws (M5 x L)	ISO 7380
Cylinder screws with hexagon socket and low head (M5 x L)	DIN 7984
Cutting screws for metric ISO thread with low head	DIN 7500

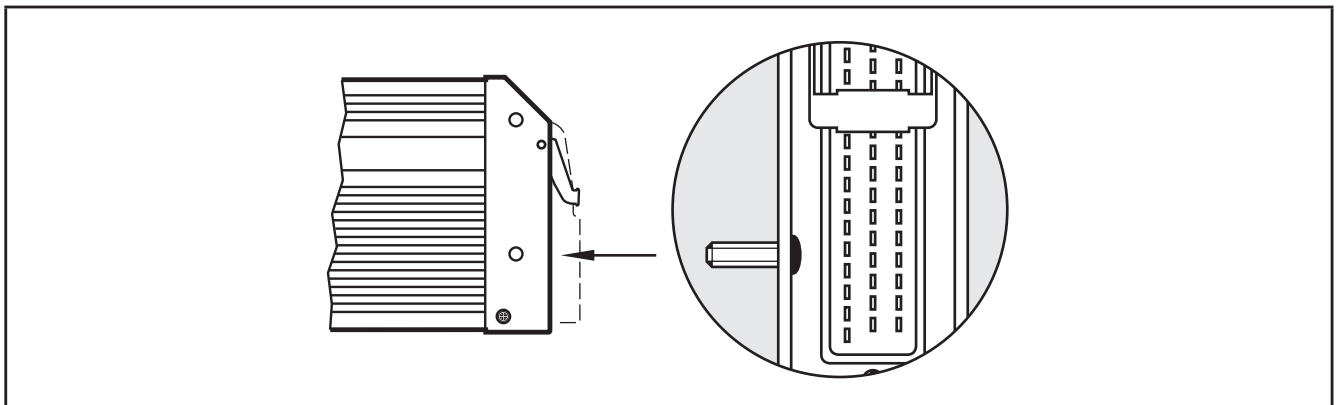

Example button head hexagon socket screw

4.2 Installation position

- ▶ Align the controller so that the cable entries of the connectors face downwards.

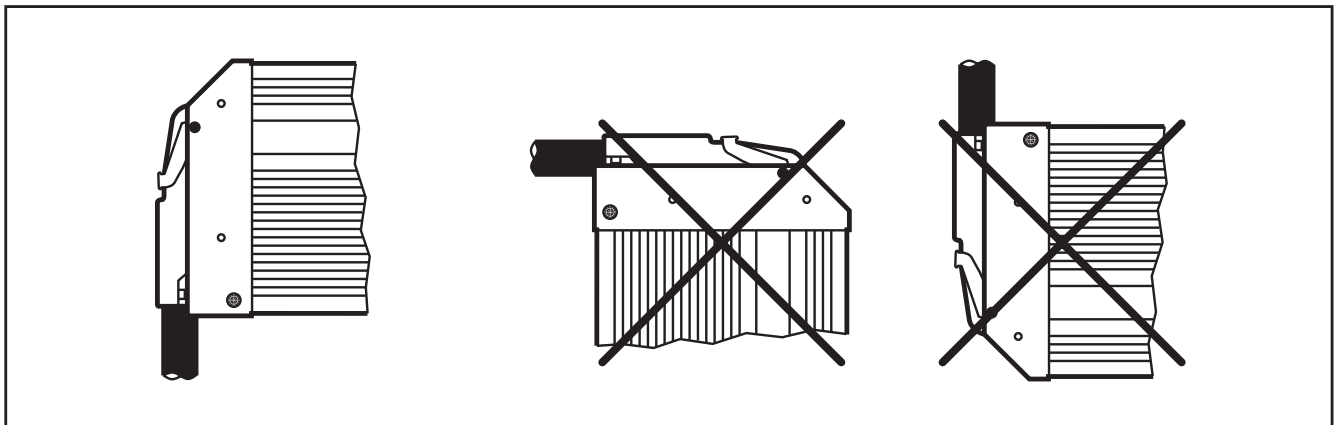

Preferred installation position

4.3 Mounting surface

NOTE

The housing must not be exposed to any torsional forces or mechanical stress.

- ▶ Use compensating elements if there is no flat mounting surface available.

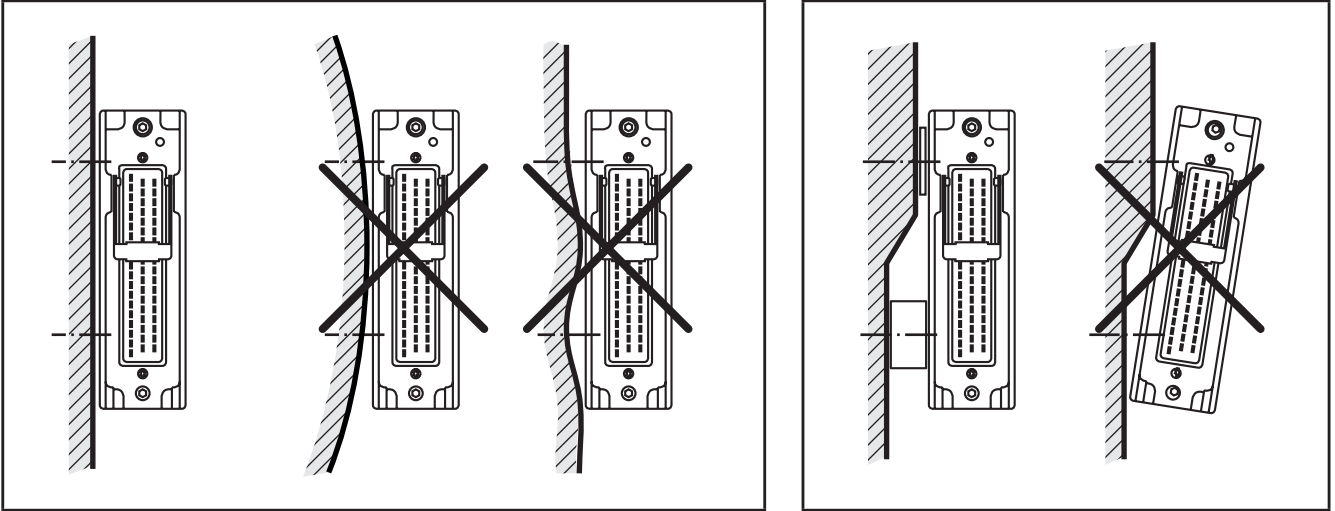

Mounting surface

4.4 Heat dissipation

- ▶ Ensure sufficient heat dissipation as the internal heating of the electronics is conducted away via the housing.
- ▶ In case of sandwich mounting of controllers use spacers.

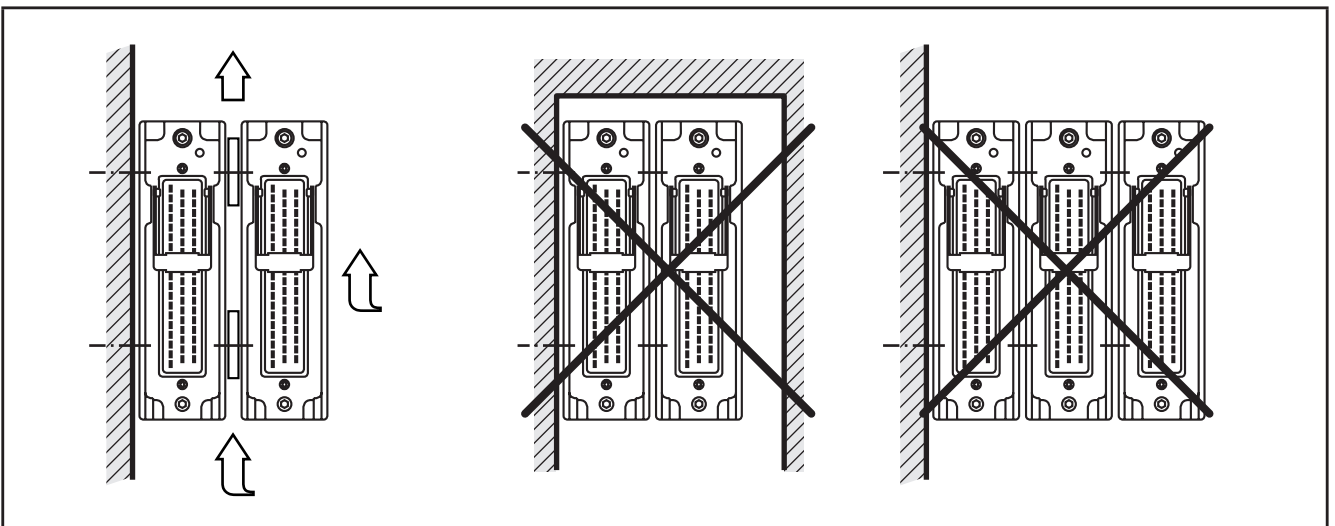

Heat dissipation and sandwich mounting

5 Electrical connection

5.1 Wiring

Wiring (→ 7 Technical data)



Only connect the connector pins as shown in the pin layout.
Unspecified connector pins remain unconnected.

- ▶ Connect all supply cables and GND terminals (St and Ex connection side).

5.1.1 Assignment of the connectors

- ▶ Note the device label.

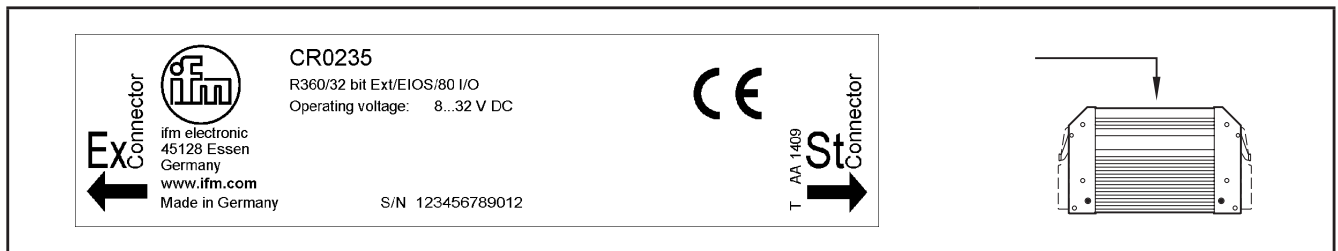

Assignment of the connectors on the device label

NOTE

Inversion of the connectors can lead to damage to the reference voltage output (pin 51, controller side).

NOTE

Inversion of the connectors can lead to damage to a connected PC or notebook.

5.2 Ground connection



To ensure the protection of the device against electrical interference and the safe function of the device, the housing must be connected to the ground of the vehicle.

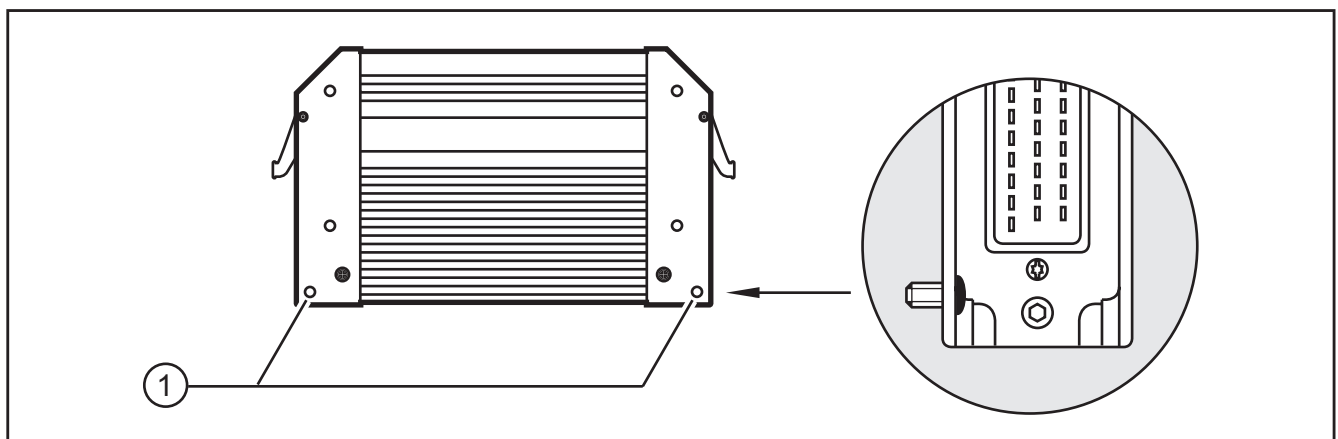

1: Drill holes for ground connection

- ▶ Establish a connection between the device and the ground of the vehicle using M5 screws.
Screws to be used (→ 4.1 Fastening)

5.3 Fuses

- ▶ The individual electric circuits must be protected in order to protect the whole system.

Connection side	Description	Potential	Pin no.	Fuse
St (Standard)	Supply voltage sensors/module	VBB_s	St-10	$\leq 2\text{ A T}$
	Supply voltage outputs	VBB_o	St-19	$\leq 15\text{ A}$
	Supply voltage via relay	VBB_R	St-01	$\leq 15\text{ A}$
Ex (Extended)	Supply voltage outputs via relay 1	VBB_1	Ex-19	$\leq 15\text{ A}$
	Supply voltage outputs via relay 2	VBB_2	Ex-01	$\leq 15\text{ A}$
	Supply voltage outputs via relay 3	VBB_3	Ex-32	$\leq 15\text{ A}$
	Supply voltage relays 1...3	VBB_{Rel}	Ex-51	$\leq 2\text{ A T}$

5.4 Laying the supply and signal cables

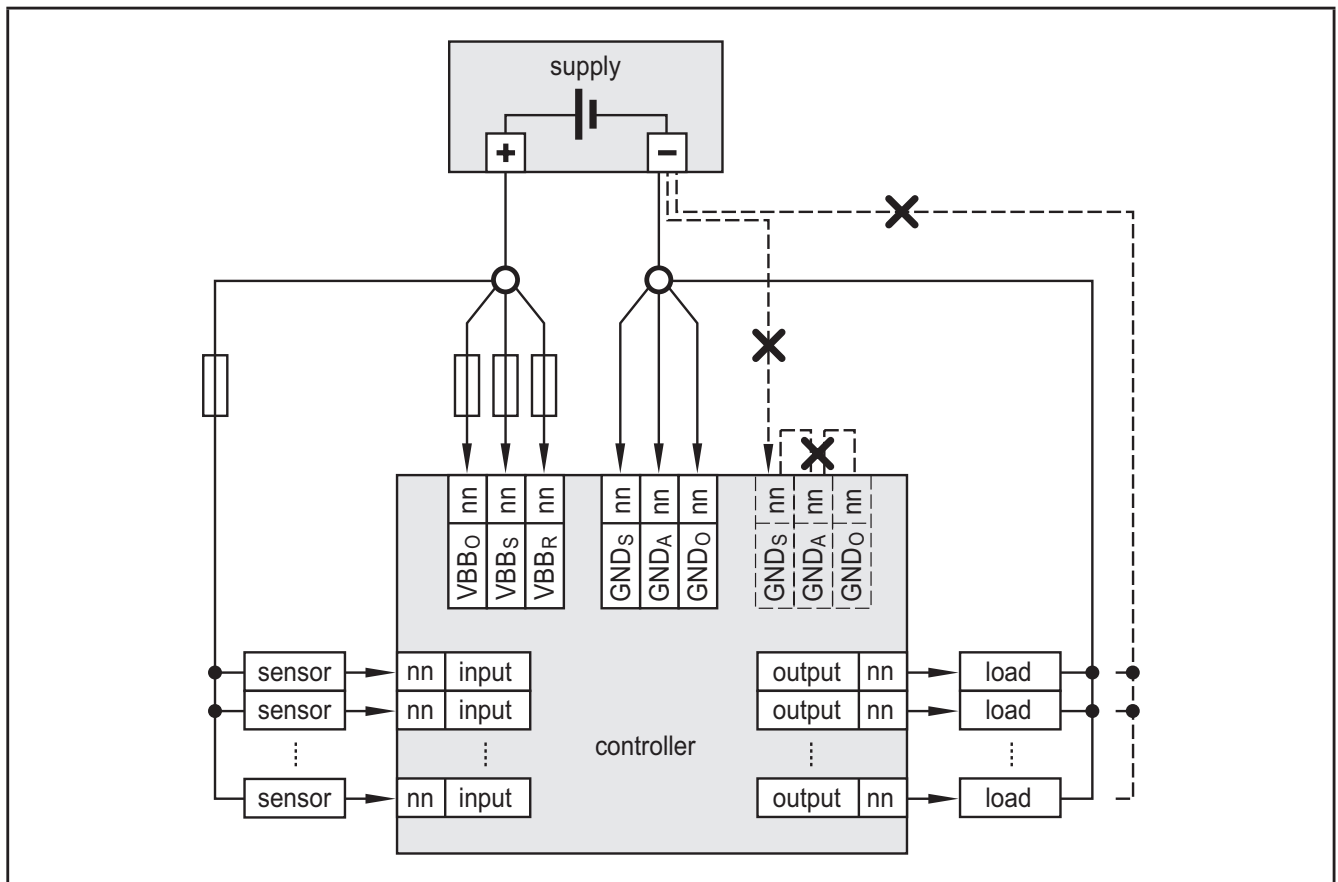

Example St connection side (X = not permissible)

⚠ WARNING

The linking of connections in the plug is not permitted and can affect the safety of operators and machinery.

- ▶ Basically all supply and signal cables must be laid separately.
- ▶ Screen signal cables in EMC critical applications.
- ▶ Connect supply and ground cables to the controller and the sensors/actuators via the respective common star point.



If a prewired connection cable is used, remove the cores with unused signal inputs and outputs.

Unused cores, in particular core loops, lead to interference coupling that can influence the connected controller.

UK

5.4.1 GND connections of the Ex connection side

- ▶ Connect all GND connections of the Ex connection side to the common GND star point.

5.5 Frequency and analogue inputs

- ▶ Operate inputs with screened cables, so that useful signals are not affected by external interference.
- ▶ Connect screens to ground on one side.

5.6 Resistor inputs

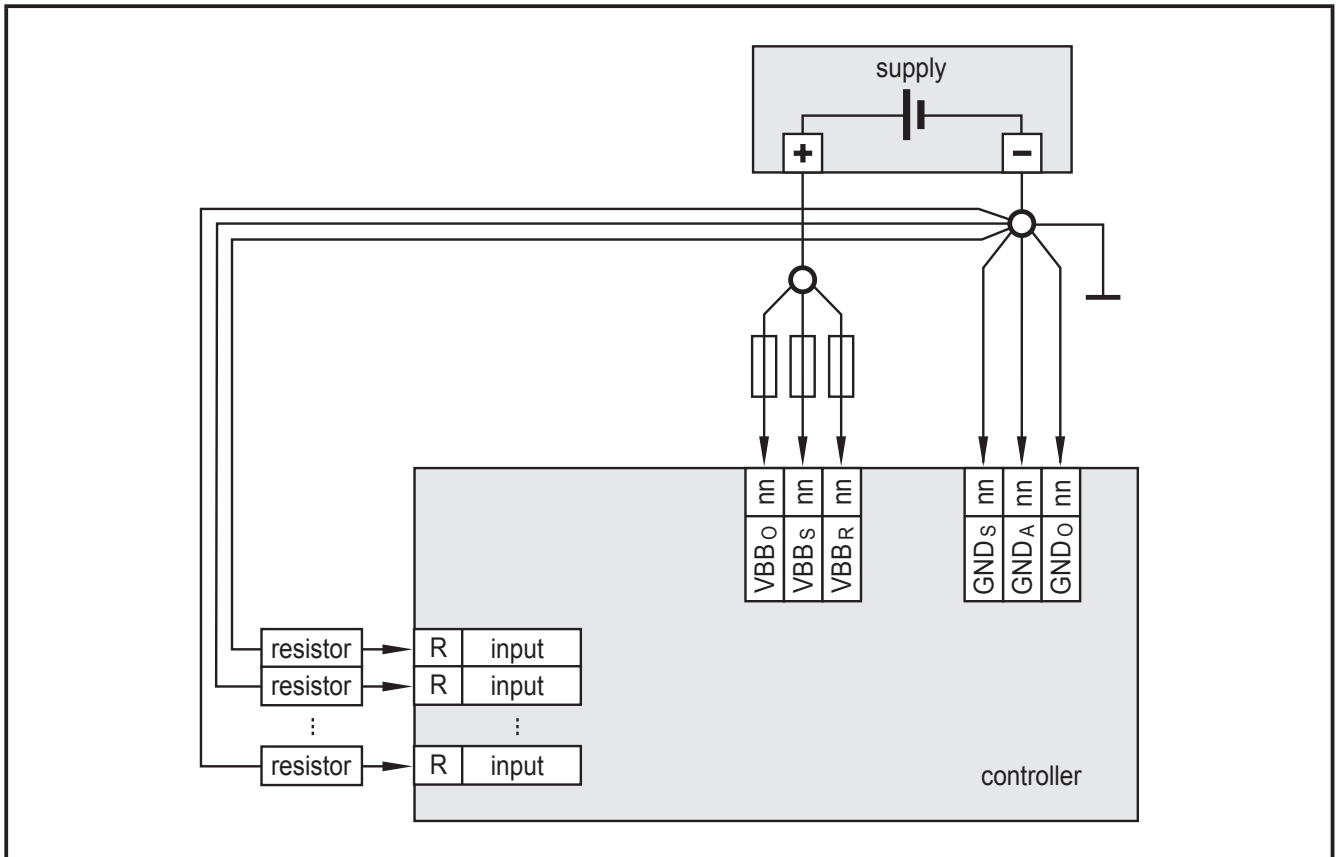

Ground return resistor inputs

- Equip each resistor with its own, separated ground return to ensure measurement accuracy.

5.6.1 Unused input I15



If input I15 is not used, configure this input as a digital input.

5.7 Supply low-side digital outputs (B_L)

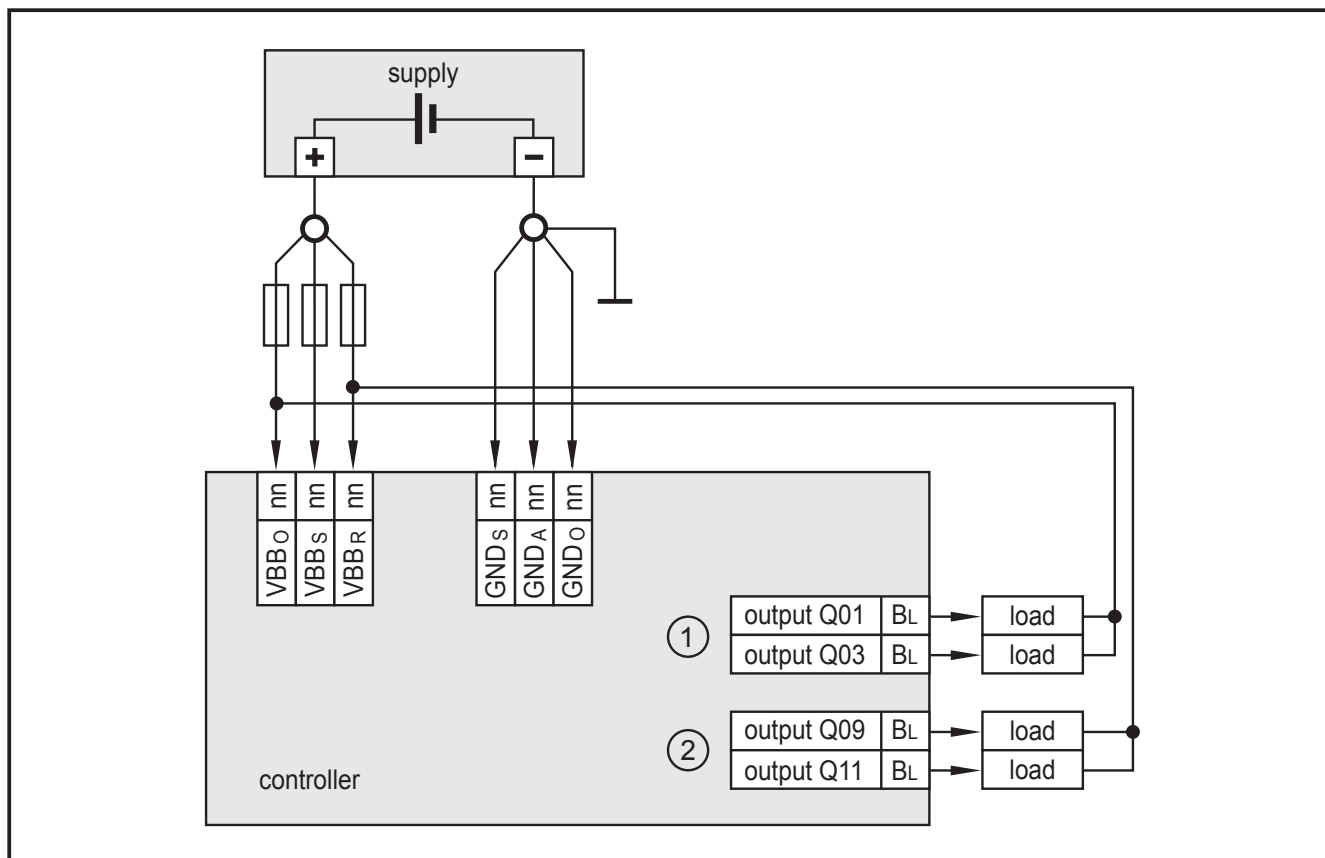

UK

Supply low-side digital outputs (B_L)

- 1: Outputs of the output group VBB_O
- 2: Outputs of the output group VBB_R

- Note the potential allocation of the outputs.
The supply of an output within an output group must only be carried out via the corresponding, protected potential.

5.8 Connection technology

NOTE

Only connect the 55-pole connectors when the supply voltage is disconnected.
No "hot plugging" is permitted.

5.9 USB interface

5.9.1 Hardware requirement

The USB controller used is USB 2.0 compatible. The USB interface is provided as a virtual COM port under Windows (→ 6.3 Communication via USB interface).

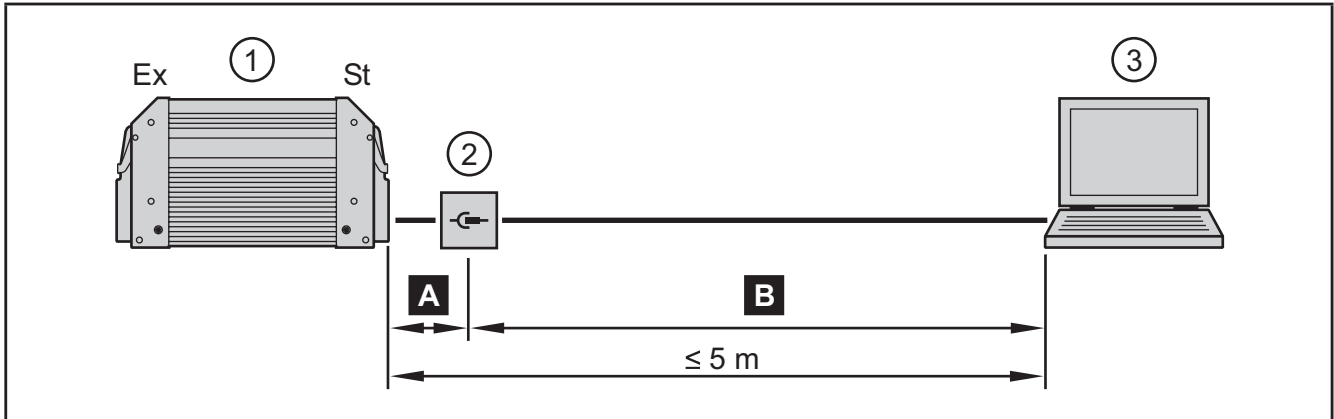

1. Controller (2 x 55-pin connector; USB connection on St side)
2. USB connector for programming and service purposes
3. Notebook/PC

- A** Connection controller to USB connector, permanent (≤ 3 m).
- ▶ Position the USB connector in immediate vicinity to the controller. The cable length "A" considerably influences the quality of the USB data transmission.
- B** Connection USB connector to notebook / PC, temporary
- ▶ Use a connection cable with the designation "Full Speed/High Speed" (= USB connection cable with twisted and screened cores).
 - ▶ Do not make a connection using several USB connection cables.
 - ▶ Remove the connection cable after the programming or service works.

5.9.2 Short-circuit protection

NOTE

The USB interface is not protected against short circuits with a live wire outside the following voltage ranges:

USB_P: -0.5...3.8 V DC

USB_N: -0.5...3.8 V DC

USB_5V: -0.5...10.0 V DC

A short circuit will destruct the USB interface.

6 Set-up

6.1 Documentation

The user can easily create the application program by means of the IEC 61131-3 compliant programming system CODESYS 2.3. In addition to the programming system CODESYS, the following documents are required for programming and commissioning of the controller:

- System manual CR0235
(alternatively CODESYS 2.3 online help)
- Manual on PLC programming with CODESYS 2.3
(alternatively CODESYS 2.3 online help)

The system manual CR0235 is available for download on the internet:
www.ifm.com → Data sheet search → CR0253 → Operating instructions

The manual on PLC programming with CODESYS 2.3 and the online help are automatically installed on the PC upon installation of the CODESYS package from the *ecomatmobile* DVD.

As an alternative, the CODESYS package can be downloaded from the internet:
www.ifm.com → Service → Download → Systems for mobile machines*

*) Download area with registration

6.1.1 ISOBUS documentation

A requirement for using the ISOBUS stack is the start-up system software CP9200. This software provides the required functionalities for the VT client and the AUX-N client.

The programming manual (supplement) "ISOBUS in the *ecomatmobile* controller" is available in the download area with registration:
www.ifm.com → Service → Download → Systems for mobile machines

6.2 Interfaces and system requirements

Communication is possible via all interfaces of the controller.



System requirement for RS-232 and CAN:
Microsoft Windows XP SP1 or higher

System requirement for USB:
Microsoft Windows XP SP2, Windows 7

6.3 Communication via USB interface



Note in general:

- The controller can be connected to any USB interface. The number of the COM port does not change.
- Only connect one controller for programming to the PC.
- Special USB and COM port drivers are required.

6.4 Install the USB drivers

The driver provides a "virtual COM port", i.e. another artificial serial interface, on the PC.

The driver file "USB CR0032 setup vxxxx.exe" is made available on the *ecomatmobile* DVD.

As an alternative, the driver is also available on the internet.

www.ifm.com → Service → Download → Systems for mobile machines*

*) Download area with registration



Changes to the system settings of the PC require extended user rights. Contact your system administrator.



Installation under Windows 7 will be described in the following. In other Windows versions there may be different menu names or structures.

- ▶ Start the driver file "USB CR0032 setup vxxxx.exe" and follow the setup instructions.
- > The driver files and a documentation will be copied to the following directory:
C:\Program Files (x86)\ifm electronic\USB_Driver_R360.
- ▶ Reboot the PC.
- ▶ Connect the controller to a free USB port
- ▶ Carry out the driver installation according to the "Installation_Guide".
The document "Installation_Guide.pdf" can be found in the following directory:
C:\Program Files (x86)\ifm electronic\USB_Driver_R360\WHQL_Certified_Driver\Documentation\Installation_Guide.pdf

The driver to be installed can be found in the following directory:

C:\Program Files (x86)\ifm electronic\USB_Driver_R360\WHQL_Certified_Driver\

6.5 Uninstall the drivers



If a driver is to be updated, the installed drivers have to be uninstalled first.

- ▶ Uninstall the drivers according to the "Installation_Guide" (chapter 4).
The document "Installation_Guide.pdf" can be found in the following directory:
C:\Program Files (x86)\ifm electronic\USB_Driver_R360\WHQL_Certified_Driver\Documentation\Installation_Guide.pdf

7 Technical data

7.1 Mechanical and electric data

CR0253

Mobile controller
ExtendedController

32-bit processor

40 inputs

40 outputs

4 CAN interfaces

ISOBUS stack
(with VT client + AUX-N client)

CODESYS 2.3

8...32 V DC

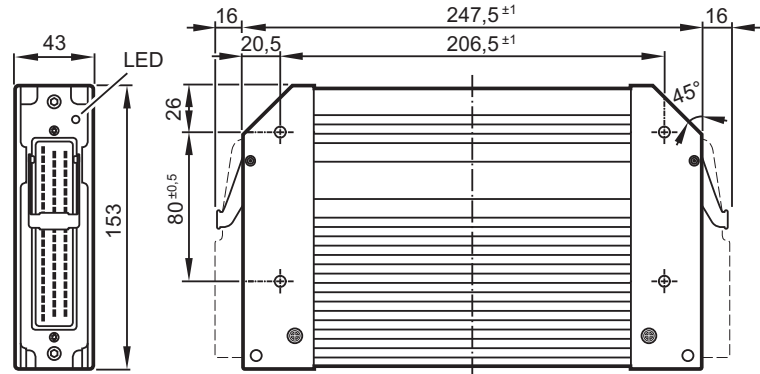

UK

Technical data

Mechanical data

Housing

Dimensions (H x W x D)

Installation

Connection

Weight

Housing/storage temperature

Protection rating

Electrical data

Input/output channels (total)

Inputs

Outputs type 1

Outputs type 2

Operating voltage

Overvoltage

Input voltage gradient

Reverse polarity protection

Current consumption

CAN interfaces 1...4

Baud rate

Communication profile

CAN interface 4

Controller as black-box system to implement a central or decentralised system design

Closed, screened metal housing with flange fastening

153 x 247.5 x 43 mm

Screw connection by means of 4 M5 x L screws to ISO 7380, DIN 7984 or DIN 7500
Mounting position horizontal or vertical to the mounting wall

2 55-pin connectors, latched, protected against reverse polarity, type AMP or
Framatome
AMP junior timer contacts, crimp connection 0.5/2.5 mm²

1.6 kg

- 40...85 °C (depending on the load) / - 40...85 °C

IP 67 (for inserted connector with individually sealed cores, e.g. EC2084)

80 (40 inputs / 40 outputs)

Configurable
Digital for positive/negative sensor signals, positive with diagnostic capabilities
Analogue (0...10 / 32 V, 0...20 mA, ratiometric)
Frequency (\leq 30 kHz)
Resistance measurement (0.016...30 k Ω , 3... 690 Ω)

Configurable
Digital positive/negative switching (high/low side)
PWM output (20...250 Hz, 16 x max. 4 A, 16 x max. 3 A)
Current-controlled (16 x 0.02...4 A, 16 x 0.02...3 A)

Digital, positive switching (high side, 8 x max. 2 A)

For the number of inputs/outputs and configuration options also see the wiring diagrams

8...32 V DC

36 V for $t \leq 10$ s

> 1.3 V/s

yes

≤ 320 mA (without external load at 24 V DC)

CAN Interface 2.0 A/B, ISO 11898
50 Kbits/s...1 Mbit/s (default 125 Kbits/s)
CANopen, CiA DS 301 V4.01, CiA DS 306 V1.3
or SAE J 1939 or free protocol

ISOBUS, VT and AUX-N client, can only be used with the system start-up software
CP9200

CR0253	Technical data																								
Serial interface Baud rate Topology Protocol	RS-232 C 9.6...115.2 Kbits/s (default 115.2 Kbits/s) Point-to-point (max. 2 participants); master-slave connection Predefined ifm protocol (INTELHEX)																								
Virtual COM port	USB, max. 1 MBaud																								
Processor	32-bit CPU Infineon TriCore 1796																								
Device monitoring	Undervoltage monitoring Watchdog function Checksum test for program and system Excess temperature monitoring																								
Process monitoring concept	Second switch-off mode for 8 outputs each via a relay																								
Physical memory	Flash: 2 Mbytes RAM: 2 Mbytes Remanent memory: 128 Kbytes																								
Memory allocation	See system manual www.ifm.com → Data sheet search → CR0253 → More information																								
Software/programming																									
Programming system	CODESYS version 2.3 (IEC 61131-3)																								
Indicators																									
Status LED	Three-colour LED (R/G/B)																								
Operating states No longer valid if the colours and/or flashing modes are changed by the application program.	<table border="1"> <thead> <tr> <th>LED colour</th> <th>Status</th> <th>Description</th> </tr> </thead> <tbody> <tr> <td>–</td> <td>off</td> <td>No operating voltage or fatal error</td> </tr> <tr> <td>Yellow</td> <td>1 x on</td> <td>Initialisation or reset checks</td> </tr> <tr> <td>Orange</td> <td>on</td> <td>Error in the start-up phase</td> </tr> <tr> <td rowspan="3">Green</td> <td>5 Hz</td> <td>No operating system loaded</td> </tr> <tr> <td>2 Hz</td> <td>Run</td> </tr> <tr> <td>on</td> <td>Stop</td> </tr> <tr> <td rowspan="2">Red</td> <td>2 Hz</td> <td>Run with error</td> </tr> <tr> <td>on</td> <td>Fatal error or stop with error</td> </tr> </tbody> </table>	LED colour	Status	Description	–	off	No operating voltage or fatal error	Yellow	1 x on	Initialisation or reset checks	Orange	on	Error in the start-up phase	Green	5 Hz	No operating system loaded	2 Hz	Run	on	Stop	Red	2 Hz	Run with error	on	Fatal error or stop with error
LED colour	Status	Description																							
–	off	No operating voltage or fatal error																							
Yellow	1 x on	Initialisation or reset checks																							
Orange	on	Error in the start-up phase																							
Green	5 Hz	No operating system loaded																							
	2 Hz	Run																							
	on	Stop																							
Red	2 Hz	Run with error																							
	on	Fatal error or stop with error																							

7.2 Test standards and regulations

CR0253	Technical data	
Test standards and regulations		
CE marking	EN 61000-6-2	Electromagnetic compatibility (EMC) Noise immunity
	EN 61000-6-4	Electromagnetic compatibility (EMC) Emission standard
	EN 61010	Safety requirements for electrical equipment for measurement, control and laboratory use
E1 marking	UN/ECE-R10	Emission standard Noise immunity with 100 V/m
Electrical tests	ISO 7637-2	Pulse 1, severity level: IV; function state C Pulse 2a, severity level: IV; function state A Pulse 2b, severity level: IV; function state C Pulse 3a, severity level: IV; function state A Pulse 3b, severity level: IV; function state A Pulse 4, severity level: IV; function state A Pulse 5, severity level: III; function state C (data valid for the 24V system) Pulse 4, severity level: III; function state C (data valid for the 12 V system)
Climatic tests	EN 60068-2-30	Damp heat, cyclic upper temperature 55°C, number of cycles: 6
	EN 60068-2-78	Damp heat, steady state Test temperature 40°C / 93% RH, Test duration: 21 days
	EN 60068-2-52	Salt spray test Severity level 3 (vehicle)
Mechanical tests	ISO 16750-3	Test VII; vibration, random Mounting location: vehicle body
	EN 60068-2-6	Vibration, sinusoidal 10...500 Hz; 0.72 mm/10 g; 10 cycles/axis
	ISO 16750-3	Bumps 30 g/6 ms; 24,000 shocks

UK

7.3 St side / input characteristics

CR0253	St side / input characteristics												
I00...07 Multifunction inputs with supply voltage independent levels for frequency measurement	<table border="1"> <tr> <td>Resolution</td> <td>12 bits</td> </tr> <tr> <td>Accuracy</td> <td>± 1 % FS (in the measuring range 0...20 mA: ± 2 % FS)</td> </tr> <tr> <td>Measuring ranges</td> <td>0...10 V, 0...32 V, 0...20 mA, ratiometric</td> </tr> </table>	Resolution	12 bits	Accuracy	± 1 % FS (in the measuring range 0...20 mA: ± 2 % FS)	Measuring ranges	0...10 V, 0...32 V, 0...20 mA, ratiometric						
	Resolution	12 bits											
	Accuracy	± 1 % FS (in the measuring range 0...20 mA: ± 2 % FS)											
	Measuring ranges	0...10 V, 0...32 V, 0...20 mA, ratiometric											
	Current input 0...20 mA (A)	<table border="1"> <tr> <td>Input resistance</td> <td>390 Ω</td> </tr> <tr> <td>Input frequency</td> <td>≤ 1 kHz (default 35 Hz)</td> </tr> </table>	Input resistance	390 Ω	Input frequency	≤ 1 kHz (default 35 Hz)							
	Input resistance	390 Ω											
Input frequency	≤ 1 kHz (default 35 Hz)												
Voltage input 0...10 V (A)	<table border="1"> <tr> <td>Input resistance</td> <td>65.6 kΩ</td> </tr> <tr> <td>Input frequency</td> <td>≤ 1 kHz (default 35 Hz)</td> </tr> </table>	Input resistance	65.6 kΩ	Input frequency	≤ 1 kHz (default 35 Hz)								
Input resistance	65.6 kΩ												
Input frequency	≤ 1 kHz (default 35 Hz)												
Voltage input 0...32 V (A)	<table border="1"> <tr> <td>Input resistance</td> <td>50.7 kΩ</td> </tr> <tr> <td>Input frequency</td> <td>≤ 1 kHz (default 35 Hz)</td> </tr> </table>	Input resistance	50.7 kΩ	Input frequency	≤ 1 kHz (default 35 Hz)								
Input resistance	50.7 kΩ												
Input frequency	≤ 1 kHz (default 35 Hz)												
Voltage input ratiometric (A)	<table border="1"> <tr> <td>Input resistance</td> <td>50.7 kΩ</td> </tr> <tr> <td>Input frequency</td> <td>≤ 1 kHz (default 35 Hz)</td> </tr> </table>	Input resistance	50.7 kΩ	Input frequency	≤ 1 kHz (default 35 Hz)								
Input resistance	50.7 kΩ												
Input frequency	≤ 1 kHz (default 35 Hz)												
Frequency input (FRQ)	<table border="1"> <tr> <td>Input resistance</td> <td>3.2 kΩ</td> </tr> <tr> <td>Input frequency</td> <td>≤ 30 kHz</td> </tr> <tr> <td>Switch-on level</td> <td>> 0.35...0.55 U_B</td> </tr> <tr> <td>Switch-off level</td> <td>< 0.29 U_B</td> </tr> </table>	Input resistance	3.2 kΩ	Input frequency	≤ 30 kHz	Switch-on level	> 0.35...0.55 U _B	Switch-off level	< 0.29 U _B				
Input resistance	3.2 kΩ												
Input frequency	≤ 30 kHz												
Switch-on level	> 0.35...0.55 U _B												
Switch-off level	< 0.29 U _B												
Digital input (B _{LH})	<table border="1"> <tr> <td>Input resistance</td> <td>3.2 kΩ</td> </tr> <tr> <td>Input frequency</td> <td>≤ 1 kHz (default 35 Hz)</td> </tr> <tr> <td>Switch-on level</td> <td>> 0.7 U_B</td> </tr> <tr> <td>Switch-off level</td> <td>< 0.3 U_B</td> </tr> <tr> <td>Diagnostics* Short circuit to VBB</td> <td>> 0.95 U_B</td> </tr> <tr> <td>Diagnostics* Short circuit to GND / wire break</td> <td>< 1 V</td> </tr> </table> <p>*) only binary low-side (B_L)</p>	Input resistance	3.2 kΩ	Input frequency	≤ 1 kHz (default 35 Hz)	Switch-on level	> 0.7 U _B	Switch-off level	< 0.3 U _B	Diagnostics* Short circuit to VBB	> 0.95 U _B	Diagnostics* Short circuit to GND / wire break	< 1 V
Input resistance	3.2 kΩ												
Input frequency	≤ 1 kHz (default 35 Hz)												
Switch-on level	> 0.7 U _B												
Switch-off level	< 0.3 U _B												
Diagnostics* Short circuit to VBB	> 0.95 U _B												
Diagnostics* Short circuit to GND / wire break	< 1 V												
I08...11 Multifunction inputs with fixed levels for frequency measurement	<table border="1"> <tr> <td>Resolution</td> <td>12 bits</td> </tr> <tr> <td>Accuracy</td> <td>± 1 % FS (in the measuring range 0...20 mA: ± 2 % FS)</td> </tr> <tr> <td>Measuring ranges</td> <td>0...10 V, 0...32 V, 0...20 mA, ratiometric</td> </tr> </table>	Resolution	12 bits	Accuracy	± 1 % FS (in the measuring range 0...20 mA: ± 2 % FS)	Measuring ranges	0...10 V, 0...32 V, 0...20 mA, ratiometric						
	Resolution	12 bits											
	Accuracy	± 1 % FS (in the measuring range 0...20 mA: ± 2 % FS)											
Measuring ranges	0...10 V, 0...32 V, 0...20 mA, ratiometric												
Current input 0...20 mA (A)	<table border="1"> <tr> <td>Input resistance</td> <td>390 Ω</td> </tr> <tr> <td>Input frequency</td> <td>≤ 1 kHz (default 35 Hz)</td> </tr> </table>	Input resistance	390 Ω	Input frequency	≤ 1 kHz (default 35 Hz)								
Input resistance	390 Ω												
Input frequency	≤ 1 kHz (default 35 Hz)												
Voltage input 0...10 V (A)	<table border="1"> <tr> <td>Input resistance</td> <td>65.6 kΩ</td> </tr> <tr> <td>Input frequency</td> <td>≤ 1 kHz (default 35 Hz)</td> </tr> </table>	Input resistance	65.6 kΩ	Input frequency	≤ 1 kHz (default 35 Hz)								
Input resistance	65.6 kΩ												
Input frequency	≤ 1 kHz (default 35 Hz)												

CR0253

Voltage input 0...32 V (A)

Input resistance	50.7 kΩ
Input frequency	≤ 1 kHz (default 35 Hz)

Voltage input ratiometric (A)

Input resistance	50.7 kΩ
Input frequency	≤ 1 kHz (default 35 Hz)

Frequency input (FRQ*)

Input resistance	3.2 kΩ / 50.7 kΩ in case of corresponding parameter setting
Input frequency	≤ 30 kHz
Switch-on level	> 4 V
Switch-off level	< 2 V

Digital input (B_i)

Input resistance	3.2 kΩ
Input frequency	≤ 1 kHz (default 35 Hz)
Switch-on level	> 0.7 U _B
Switch-off level	< 0.3 U _B
Diagnostics Short circuit to VBB	> 0.95 U _B
Diagnostics Short circuit to GND / wire break	< 1 V

**I12...14
Digital / resistor inputs**Digital input (B_i)

Resolution	12 bits
Input resistance	3.2 kΩ
Input frequency	≤ 1 kHz (default 35 Hz)
Switch-on level	> 0.7 U _B
Switch-off level	< 0.3 U _B
Diagnostics Short circuit to VBB	> 0.95 U _B
Diagnostics Short circuit to GND / wire break	< 1 V
Voltage on the pin when not connected	≤ 0.2 V

Resistor input (R)

Measuring current	< 2.0 mA
Input frequency	50 Hz
Measuring range	0.016...30 kΩ
Accuracy	± 2 % FS: 0.016...3 kΩ ± 5 % FS: 3...15 kΩ ± 10 % FS: 15...30 kΩ
Diagnostics Short circuit to VBB / wire break	> 31 kΩ

CR0253
I15 Digital / resistor input
Digital input (B _L)
Resistor input (R)
Note
Test input (pin 50)
ISOBUS documentation
Abbreviations

St side / input characteristics	
Resolution	12 bits
Input resistance	3.2 kΩ
Input frequency	≤ 1 kHz (default 35 Hz)
Switch-on level	> 0.7 U _B
Switch-off level	< 0.3 U _B
Diagnostics Short circuit to VBB	> 0.95 U _B
Diagnostics Short circuit to GND / wire break	< 1 V
Voltage on the pin when not connected	≤ 0.2 V
Measuring current	< 5.0 mA
Input frequency	50 Hz
Measuring range	3...680 Ω
Accuracy	± 4 % FS
Diagnostics Short circuit to VBB / wire break	> 700 Ω
<p>During the test mode (e.g. programming) the connector pin must be connected to VBB_s (8...32 V DC). For the "RUN" mode, connect the test input to GND.</p>	
<p>Programming manual (supplement) "ISOBUS in the ecomatmobile controller" www.ifm.com → Service → Download → Systems for mobile machines</p>	
<p>Observe the notes on the configuration of the inputs/outputs! (system manual "ExtendedController CR0235")</p>	
A	Analogue
B _H	Binary high side
B _L	Binary low side
FRQ	Frequency / pulse inputs with levels depending on the supply voltage
FRQ*	Frequency / pulse inputs with fixed levels
H	H-bridge function
PWM	Pulse width modulation
R	Resistor input
VBB _O	Supply outputs
VBB _s	Supply sensors/module
VBB _R	Supply via relay

7.4 St side / output characteristics

CR0253	St side / output characteristics																														
Q00...03 Q08...11 Digital/PWM outputs (type 1)	<table border="1"> <tr> <td>Protective circuit for inductive loads</td> <td>Integrated</td> </tr> <tr> <td>Diagnosis wire break</td> <td>via current feedback</td> </tr> <tr> <td>Diagnosis short circuit</td> <td>via current feedback</td> </tr> </table> <table border="1"> <tr> <td>Switching voltage</td> <td>8...32 V DC</td> </tr> <tr> <td>Switching current</td> <td>0.01...2 A / 0.02...4 A (of which 4 with H-bridge function)</td> </tr> </table> <table border="1"> <tr> <td>Output frequency</td> <td>20...250 Hz (per channel)</td> </tr> <tr> <td>Pulse/pause ratio</td> <td>1...1000 ‰ (adjustable via software)</td> </tr> <tr> <td>Resolution</td> <td>1 ‰</td> </tr> <tr> <td>Switching current</td> <td>0.01...2 A / 0.02...4 A (of which 4 with H-bridge function)</td> </tr> </table> <table border="1"> <tr> <td>Output frequency</td> <td>20...250 Hz (per channel)</td> </tr> <tr> <td>Control range</td> <td>0.01...2 A / 0.02...4 A</td> </tr> <tr> <td>Setting resolution</td> <td>1 mA</td> </tr> <tr> <td>Control resolution</td> <td>1 mA / 2 mA</td> </tr> <tr> <td>Load resistance</td> <td>≥ 6 Ω / ≥ 3 Ω (at 12 V DC) ≥ 12 Ω / ≥ 6 Ω (at 24 V DC)</td> </tr> <tr> <td>Accuracy</td> <td>± 2 % FS (for inductive loads)</td> </tr> </table>	Protective circuit for inductive loads	Integrated	Diagnosis wire break	via current feedback	Diagnosis short circuit	via current feedback	Switching voltage	8...32 V DC	Switching current	0.01...2 A / 0.02...4 A (of which 4 with H-bridge function)	Output frequency	20...250 Hz (per channel)	Pulse/pause ratio	1...1000 ‰ (adjustable via software)	Resolution	1 ‰	Switching current	0.01...2 A / 0.02...4 A (of which 4 with H-bridge function)	Output frequency	20...250 Hz (per channel)	Control range	0.01...2 A / 0.02...4 A	Setting resolution	1 mA	Control resolution	1 mA / 2 mA	Load resistance	≥ 6 Ω / ≥ 3 Ω (at 12 V DC) ≥ 12 Ω / ≥ 6 Ω (at 24 V DC)	Accuracy	± 2 % FS (for inductive loads)
Protective circuit for inductive loads	Integrated																														
Diagnosis wire break	via current feedback																														
Diagnosis short circuit	via current feedback																														
Switching voltage	8...32 V DC																														
Switching current	0.01...2 A / 0.02...4 A (of which 4 with H-bridge function)																														
Output frequency	20...250 Hz (per channel)																														
Pulse/pause ratio	1...1000 ‰ (adjustable via software)																														
Resolution	1 ‰																														
Switching current	0.01...2 A / 0.02...4 A (of which 4 with H-bridge function)																														
Output frequency	20...250 Hz (per channel)																														
Control range	0.01...2 A / 0.02...4 A																														
Setting resolution	1 mA																														
Control resolution	1 mA / 2 mA																														
Load resistance	≥ 6 Ω / ≥ 3 Ω (at 12 V DC) ≥ 12 Ω / ≥ 6 Ω (at 24 V DC)																														
Accuracy	± 2 % FS (for inductive loads)																														
Digital output (B _n and B _{nL})																															
PWM output (PWM)																															
Current-controlled output (PWM _i)																															
Q04...07 Q12...15 Digital/PWM outputs (type 1)	<table border="1"> <tr> <td>Protective circuit for inductive loads</td> <td>Integrated</td> </tr> <tr> <td>Diagnosis wire break</td> <td>via current feedback</td> </tr> <tr> <td>Diagnosis short circuit</td> <td>via current feedback</td> </tr> </table> <table border="1"> <tr> <td>Switching voltage</td> <td>8...32 V DC</td> </tr> <tr> <td>Switching current</td> <td>0.02...3 A</td> </tr> </table> <table border="1"> <tr> <td>Output frequency</td> <td>20...250 Hz (per channel)</td> </tr> <tr> <td>Pulse/pause ratio</td> <td>1...1000 ‰ (adjustable via software)</td> </tr> <tr> <td>Resolution</td> <td>1 ‰</td> </tr> <tr> <td>Switching current</td> <td>0.02...3 A</td> </tr> </table> <table border="1"> <tr> <td>Output frequency</td> <td>20...250 Hz (per channel)</td> </tr> <tr> <td>Control range</td> <td>0.02...3 A</td> </tr> <tr> <td>Setting resolution</td> <td>1 mA</td> </tr> <tr> <td>Control resolution</td> <td>2 mA</td> </tr> <tr> <td>Load resistance</td> <td>≥ 4 Ω / (at 12 V DC) ≥ 8 Ω / (at 24 V DC)</td> </tr> <tr> <td>Accuracy</td> <td>± 2 % FS (for inductive loads)</td> </tr> </table>	Protective circuit for inductive loads	Integrated	Diagnosis wire break	via current feedback	Diagnosis short circuit	via current feedback	Switching voltage	8...32 V DC	Switching current	0.02...3 A	Output frequency	20...250 Hz (per channel)	Pulse/pause ratio	1...1000 ‰ (adjustable via software)	Resolution	1 ‰	Switching current	0.02...3 A	Output frequency	20...250 Hz (per channel)	Control range	0.02...3 A	Setting resolution	1 mA	Control resolution	2 mA	Load resistance	≥ 4 Ω / (at 12 V DC) ≥ 8 Ω / (at 24 V DC)	Accuracy	± 2 % FS (for inductive loads)
Protective circuit for inductive loads	Integrated																														
Diagnosis wire break	via current feedback																														
Diagnosis short circuit	via current feedback																														
Switching voltage	8...32 V DC																														
Switching current	0.02...3 A																														
Output frequency	20...250 Hz (per channel)																														
Pulse/pause ratio	1...1000 ‰ (adjustable via software)																														
Resolution	1 ‰																														
Switching current	0.02...3 A																														
Output frequency	20...250 Hz (per channel)																														
Control range	0.02...3 A																														
Setting resolution	1 mA																														
Control resolution	2 mA																														
Load resistance	≥ 4 Ω / (at 12 V DC) ≥ 8 Ω / (at 24 V DC)																														
Accuracy	± 2 % FS (for inductive loads)																														
Digital output (B _n)																															
PWM output (PWM)																															
Current-controlled output (PWM _i)																															

CR0253	St side / output characteristics								
Reference voltage $V_{REF\ OUT}$ (sensor supply)	For sensors and joysticks 5/10 V, 400 mA, accuracy $\pm 7\%$ Short-circuit proof and overload protected (10 V reference only from a supply voltage $U_b \geq 13\text{ V}$)								
Internal relays	NO contacts for the second switch-off way of the outputs. One relay in series of 8 semiconductor outputs each. Forced control via the hardware and additional control via the user program. The relays must always be switched without load!								
	<table border="1"> <tr> <td>Switching current</td> <td>0.1...15 A</td> </tr> <tr> <td>Overload current</td> <td>20 A</td> </tr> <tr> <td>Number of operating cycles (without load)</td> <td>$\geq 10^6$</td> </tr> <tr> <td>Switching time constant</td> <td>$\leq 3\text{ ms}$</td> </tr> </table>	Switching current	0.1...15 A	Overload current	20 A	Number of operating cycles (without load)	$\geq 10^6$	Switching time constant	$\leq 3\text{ ms}$
Switching current	0.1...15 A								
Overload current	20 A								
Number of operating cycles (without load)	$\geq 10^6$								
Switching time constant	$\leq 3\text{ ms}$								
Load current per output group (VBB_R, VBB_O)	$\leq 12\text{ A}$ (for continuous operation $\leq 6\text{ A}$; i.e. operation $\geq 10\text{ min}$)								
Overload protection (valid for all outputs)	$\leq 5\text{ minutes}$ (at 100% overload)								
Short-circuit strength to GND	Switch-off of the outputs is carried out via the output driver								
Abbreviations	<p>A Analogue B_H Binary high side B_L Binary low side FRQ Frequency / pulse inputs with levels depending on the supply voltage FRQ* Frequency / pulse inputs with fixed levels H H-bridge function PWM Pulse width modulation R Resistor input VBB_O Supply outputs VBB_S Supply sensors/module VBB_R Supply via relay</p>								

7.5 Ex side / input characteristics

CR0253	Ex side / input characteristics												
I00_E...23_E Analogue / digital inputs	<table border="1"> <tr> <td>Resolution</td> <td>12 bits</td> </tr> <tr> <td>Accuracy</td> <td>$\pm 1\%$ FS (in the measuring range 0...20 mA: $\pm 2\%$ FS)</td> </tr> <tr> <td>Measuring ranges</td> <td>0...10 V, 0...32 V, 0...20 mA, ratiometric</td> </tr> </table>	Resolution	12 bits	Accuracy	$\pm 1\%$ FS (in the measuring range 0...20 mA: $\pm 2\%$ FS)	Measuring ranges	0...10 V, 0...32 V, 0...20 mA, ratiometric						
Resolution	12 bits												
Accuracy	$\pm 1\%$ FS (in the measuring range 0...20 mA: $\pm 2\%$ FS)												
Measuring ranges	0...10 V, 0...32 V, 0...20 mA, ratiometric												
Current input 0...20 mA (A)	<table border="1"> <tr> <td>Input resistance</td> <td>390 Ω</td> </tr> <tr> <td>Input frequency</td> <td>≤ 1 kHz (default 35 Hz)</td> </tr> </table>	Input resistance	390 Ω	Input frequency	≤ 1 kHz (default 35 Hz)								
Input resistance	390 Ω												
Input frequency	≤ 1 kHz (default 35 Hz)												
Voltage input 0...10 V (A)	<table border="1"> <tr> <td>Input resistance</td> <td>65.6 kΩ</td> </tr> <tr> <td>Input frequency</td> <td>≤ 1 kHz (default 35 Hz)</td> </tr> </table>	Input resistance	65.6 k Ω	Input frequency	≤ 1 kHz (default 35 Hz)								
Input resistance	65.6 k Ω												
Input frequency	≤ 1 kHz (default 35 Hz)												
Voltage input 0...32 V (A)	<table border="1"> <tr> <td>Input resistance</td> <td>50.7 kΩ</td> </tr> <tr> <td>Input frequency</td> <td>≤ 1 kHz (default 35 Hz)</td> </tr> </table>	Input resistance	50.7 k Ω	Input frequency	≤ 1 kHz (default 35 Hz)								
Input resistance	50.7 k Ω												
Input frequency	≤ 1 kHz (default 35 Hz)												
Voltage input ratiometric (A)	<table border="1"> <tr> <td>Input resistance</td> <td>50.7 kΩ</td> </tr> <tr> <td>Input frequency</td> <td>≤ 1 kHz (default 35 Hz)</td> </tr> </table>	Input resistance	50.7 k Ω	Input frequency	≤ 1 kHz (default 35 Hz)								
Input resistance	50.7 k Ω												
Input frequency	≤ 1 kHz (default 35 Hz)												
Frequency input (FRQ) only I00_E...15_E	<table border="1"> <tr> <td>Input resistance</td> <td>3.2 kΩ</td> </tr> <tr> <td>Input frequency</td> <td>≤ 30 kHz</td> </tr> <tr> <td>Switch-on level</td> <td>$> 0.35...0.55 U_B$</td> </tr> <tr> <td>Switch-off level</td> <td>$< 0.29 U_B$</td> </tr> </table>	Input resistance	3.2 k Ω	Input frequency	≤ 30 kHz	Switch-on level	$> 0.35...0.55 U_B$	Switch-off level	$< 0.29 U_B$				
Input resistance	3.2 k Ω												
Input frequency	≤ 30 kHz												
Switch-on level	$> 0.35...0.55 U_B$												
Switch-off level	$< 0.29 U_B$												
Digital input (B_{LH})	<table border="1"> <tr> <td>Input resistance</td> <td>3.2 kΩ</td> </tr> <tr> <td>Input frequency</td> <td>≤ 1 kHz (default 35 Hz)</td> </tr> <tr> <td>Switch-on level</td> <td>$> 0.7 U_B$</td> </tr> <tr> <td>Switch-off level</td> <td>$< 0.3 U_B$</td> </tr> <tr> <td>Diagnostics* Short circuit to VBB</td> <td>$> 0.95 U_B$</td> </tr> <tr> <td>Diagnostics* Short circuit to GND / wire break</td> <td>< 1 V</td> </tr> </table>	Input resistance	3.2 k Ω	Input frequency	≤ 1 kHz (default 35 Hz)	Switch-on level	$> 0.7 U_B$	Switch-off level	$< 0.3 U_B$	Diagnostics* Short circuit to VBB	$> 0.95 U_B$	Diagnostics* Short circuit to GND / wire break	< 1 V
Input resistance	3.2 k Ω												
Input frequency	≤ 1 kHz (default 35 Hz)												
Switch-on level	$> 0.7 U_B$												
Switch-off level	$< 0.3 U_B$												
Diagnostics* Short circuit to VBB	$> 0.95 U_B$												
Diagnostics* Short circuit to GND / wire break	< 1 V												
	*) only binary low-side (B_L)												

UK

7.6 Ex side / output characteristics

CR0253	Ex side / output characteristics																														
Q00_E...03_E Q08_E...11_E Digital/PWM outputs (type 1)	<table border="1"> <tr> <td>Protective circuit for inductive loads</td> <td>Integrated</td> </tr> <tr> <td>Diagnosis wire break</td> <td>via current feedback</td> </tr> <tr> <td>Diagnosis short circuit</td> <td>via current feedback</td> </tr> </table> <table border="1"> <tr> <td>Switching voltage</td> <td>8...32 V DC</td> </tr> <tr> <td>Switching current</td> <td>0.01...2 A / 0.02...4 A (of which 4 with H-bridge function)</td> </tr> </table> <table border="1"> <tr> <td>Output frequency</td> <td>20...250 Hz (per channel)</td> </tr> <tr> <td>Pulse/pause ratio</td> <td>1...1000 ‰ (adjustable via software)</td> </tr> <tr> <td>Resolution</td> <td>1 ‰</td> </tr> <tr> <td>Switching current</td> <td>0.01...2 A / 0.02...4 A (of which 4 with H-bridge function)</td> </tr> </table> <table border="1"> <tr> <td>Output frequency</td> <td>20...250 Hz (per channel)</td> </tr> <tr> <td>Control range</td> <td>0.01...2 A / 0.02...4 A</td> </tr> <tr> <td>Setting resolution</td> <td>1 mA</td> </tr> <tr> <td>Control resolution</td> <td>1 mA / 2 mA</td> </tr> <tr> <td>Load resistance</td> <td>≥ 6 Ω / ≥ 3 Ω (at 12 V DC) ≥ 12 Ω / ≥ 6 Ω (at 24 V DC)</td> </tr> <tr> <td>Accuracy</td> <td>± 2 % FS (for inductive loads)</td> </tr> </table>	Protective circuit for inductive loads	Integrated	Diagnosis wire break	via current feedback	Diagnosis short circuit	via current feedback	Switching voltage	8...32 V DC	Switching current	0.01...2 A / 0.02...4 A (of which 4 with H-bridge function)	Output frequency	20...250 Hz (per channel)	Pulse/pause ratio	1...1000 ‰ (adjustable via software)	Resolution	1 ‰	Switching current	0.01...2 A / 0.02...4 A (of which 4 with H-bridge function)	Output frequency	20...250 Hz (per channel)	Control range	0.01...2 A / 0.02...4 A	Setting resolution	1 mA	Control resolution	1 mA / 2 mA	Load resistance	≥ 6 Ω / ≥ 3 Ω (at 12 V DC) ≥ 12 Ω / ≥ 6 Ω (at 24 V DC)	Accuracy	± 2 % FS (for inductive loads)
Protective circuit for inductive loads	Integrated																														
Diagnosis wire break	via current feedback																														
Diagnosis short circuit	via current feedback																														
Switching voltage	8...32 V DC																														
Switching current	0.01...2 A / 0.02...4 A (of which 4 with H-bridge function)																														
Output frequency	20...250 Hz (per channel)																														
Pulse/pause ratio	1...1000 ‰ (adjustable via software)																														
Resolution	1 ‰																														
Switching current	0.01...2 A / 0.02...4 A (of which 4 with H-bridge function)																														
Output frequency	20...250 Hz (per channel)																														
Control range	0.01...2 A / 0.02...4 A																														
Setting resolution	1 mA																														
Control resolution	1 mA / 2 mA																														
Load resistance	≥ 6 Ω / ≥ 3 Ω (at 12 V DC) ≥ 12 Ω / ≥ 6 Ω (at 24 V DC)																														
Accuracy	± 2 % FS (for inductive loads)																														
Digital output (B _n and B _{nL})																															
PWM output (PWM)																															
Current-controlled output (PWM _i)																															
Q04_E...07_E Q12_E...15_E Digital/PWM outputs (type 1)	<table border="1"> <tr> <td>Protective circuit for inductive loads</td> <td>Integrated</td> </tr> <tr> <td>Diagnosis wire break</td> <td>via current feedback</td> </tr> <tr> <td>Diagnosis short circuit</td> <td>via current feedback</td> </tr> </table> <table border="1"> <tr> <td>Switching voltage</td> <td>8...32 V DC</td> </tr> <tr> <td>Switching current</td> <td>0.02...3 A</td> </tr> </table> <table border="1"> <tr> <td>Output frequency</td> <td>20...250 Hz (per channel)</td> </tr> <tr> <td>Pulse/pause ratio</td> <td>1...1000 ‰ (adjustable via software)</td> </tr> <tr> <td>Resolution</td> <td>1 ‰</td> </tr> <tr> <td>Switching current</td> <td>0.02...3 A</td> </tr> </table> <table border="1"> <tr> <td>Output frequency</td> <td>20...250 Hz (per channel)</td> </tr> <tr> <td>Control range</td> <td>0.02...3 A</td> </tr> <tr> <td>Setting resolution</td> <td>1 mA</td> </tr> <tr> <td>Control resolution</td> <td>2 mA</td> </tr> <tr> <td>Load resistance</td> <td>≥ 4 Ω / (at 12 V DC) ≥ 8 Ω / (at 24 V DC)</td> </tr> <tr> <td>Accuracy</td> <td>± 2 % FS (for inductive loads)</td> </tr> </table>	Protective circuit for inductive loads	Integrated	Diagnosis wire break	via current feedback	Diagnosis short circuit	via current feedback	Switching voltage	8...32 V DC	Switching current	0.02...3 A	Output frequency	20...250 Hz (per channel)	Pulse/pause ratio	1...1000 ‰ (adjustable via software)	Resolution	1 ‰	Switching current	0.02...3 A	Output frequency	20...250 Hz (per channel)	Control range	0.02...3 A	Setting resolution	1 mA	Control resolution	2 mA	Load resistance	≥ 4 Ω / (at 12 V DC) ≥ 8 Ω / (at 24 V DC)	Accuracy	± 2 % FS (for inductive loads)
Protective circuit for inductive loads	Integrated																														
Diagnosis wire break	via current feedback																														
Diagnosis short circuit	via current feedback																														
Switching voltage	8...32 V DC																														
Switching current	0.02...3 A																														
Output frequency	20...250 Hz (per channel)																														
Pulse/pause ratio	1...1000 ‰ (adjustable via software)																														
Resolution	1 ‰																														
Switching current	0.02...3 A																														
Output frequency	20...250 Hz (per channel)																														
Control range	0.02...3 A																														
Setting resolution	1 mA																														
Control resolution	2 mA																														
Load resistance	≥ 4 Ω / (at 12 V DC) ≥ 8 Ω / (at 24 V DC)																														
Accuracy	± 2 % FS (for inductive loads)																														
Digital output (B _n)																															
PWM output (PWM)																															
Current-controlled output (PWM _i)																															

CR0253	Ex side / output characteristics						
Q16_E...Q23_E Digital outputs (type 2)	<table border="1"> <tr> <td>Switching voltage</td> <td>8...32 V DC</td> </tr> <tr> <td>Switching current</td> <td>8 x 0.01...2 A</td> </tr> <tr> <td>Diagnosis via voltage feedback</td> <td>Wire break/short circuit</td> </tr> </table>	Switching voltage	8...32 V DC	Switching current	8 x 0.01...2 A	Diagnosis via voltage feedback	Wire break/short circuit
Switching voltage	8...32 V DC						
Switching current	8 x 0.01...2 A						
Diagnosis via voltage feedback	Wire break/short circuit						
Digital output (B _H)							
Internal relays	<p>NO contacts for the second switch-off way of the outputs. One relay in series of 8 semiconductor outputs each. Forced control via the hardware and additional control via the user program.</p> <p>The relays must always be switched without load!</p>						
Load current per output group (VBB ₁ , VBB ₂ , VBB ₃)	<p>≤ 12 A (for continuous operation ≤ 6 A; i.e. operation ≥ 10 min)</p>						
Overload protection (valid for all outputs)	<p>≤ 5 minutes (at 100% overload)</p>						
Short-circuit strength to GND	<p>Switch-off of the outputs is carried out via the output driver</p>						

UK

7.7 St side / wiring

CR0253

Technical data

Wiring

St side

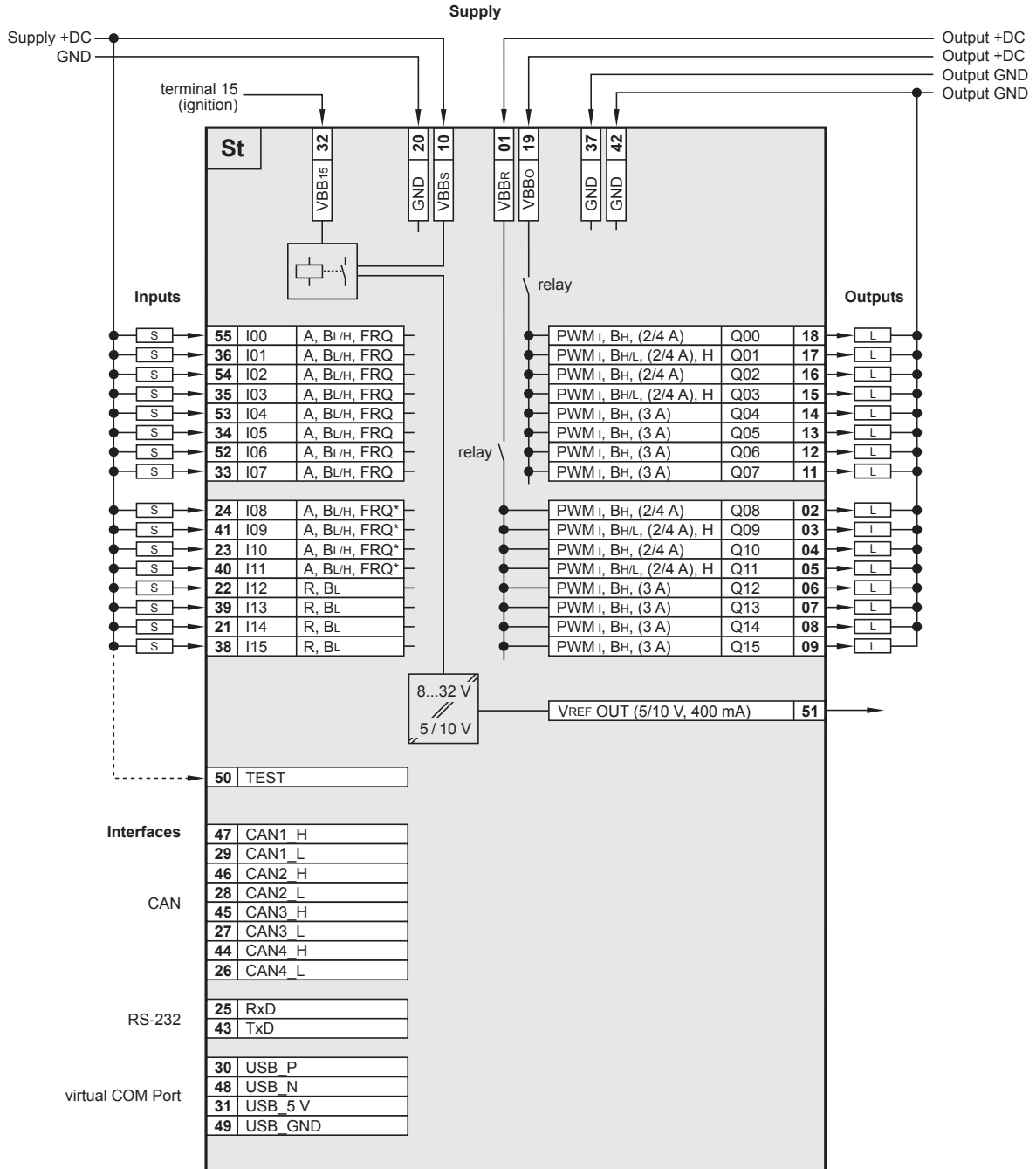

Abbreviations

- A Analogue
- B_H Binary high side
- B_L Binary low side
- FRQ Frequency / pulse inputs with levels depending on the supply voltage
- FRQ* Frequency / pulse inputs with fixed levels
- H H-bridge function
- PWM Pulse width modulation
- R Resistor input
- VBB_o Supply outputs
- VBB_s Supply sensors/module
- VBB_r Supply via relay

7.8 Ex side / wiring

CR0253

Technical data

Wiring

Ex side

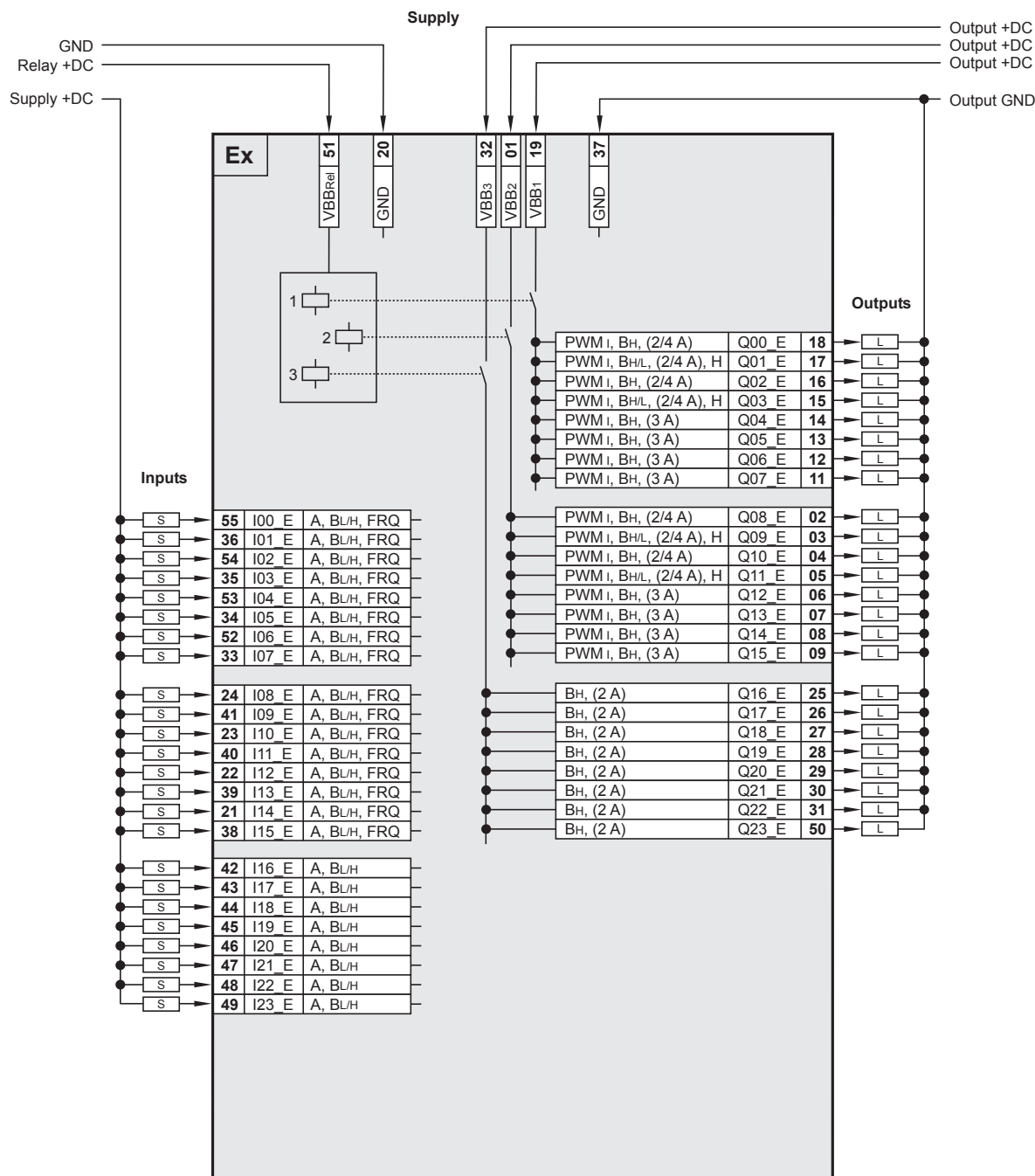

Abbreviations

- A Analogue
- B_H Binary high side
- B_L Binary low side
- FRQ Frequency/pulse inputs
- H H-bridge function
- PWM Pulse width modulation
- VBB... Supply output group
- St Standard side
- Ex Extended side

8 Maintenance, repair and disposal

The device is maintenance-free.

- ▶ Do not open the housing as the device does not contain any components which can be repaired by the user. The device must only be repaired by the manufacturer.
- ▶ Dispose of the device in accordance with the national environmental regulations.

9 Approvals/standards

Test standards and regulations (→ 7 Technical data)

The EC declaration of conformity and approvals can be found at:
www.ifm.com → Data sheet search → CR0253 → More information