

ifm electronic

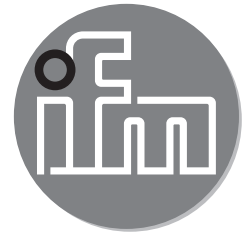

Installation Instructions
Protective cover

efector500[®]

E30101 / E30104

UK

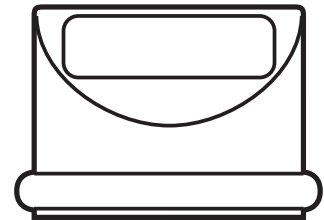

05/2011

706012/00

ifm electronic gmbh • Friedrichstr. 1 • 45128 Essen • Germany
<http://www.ifm.com> • e-mail: info@ifm.com

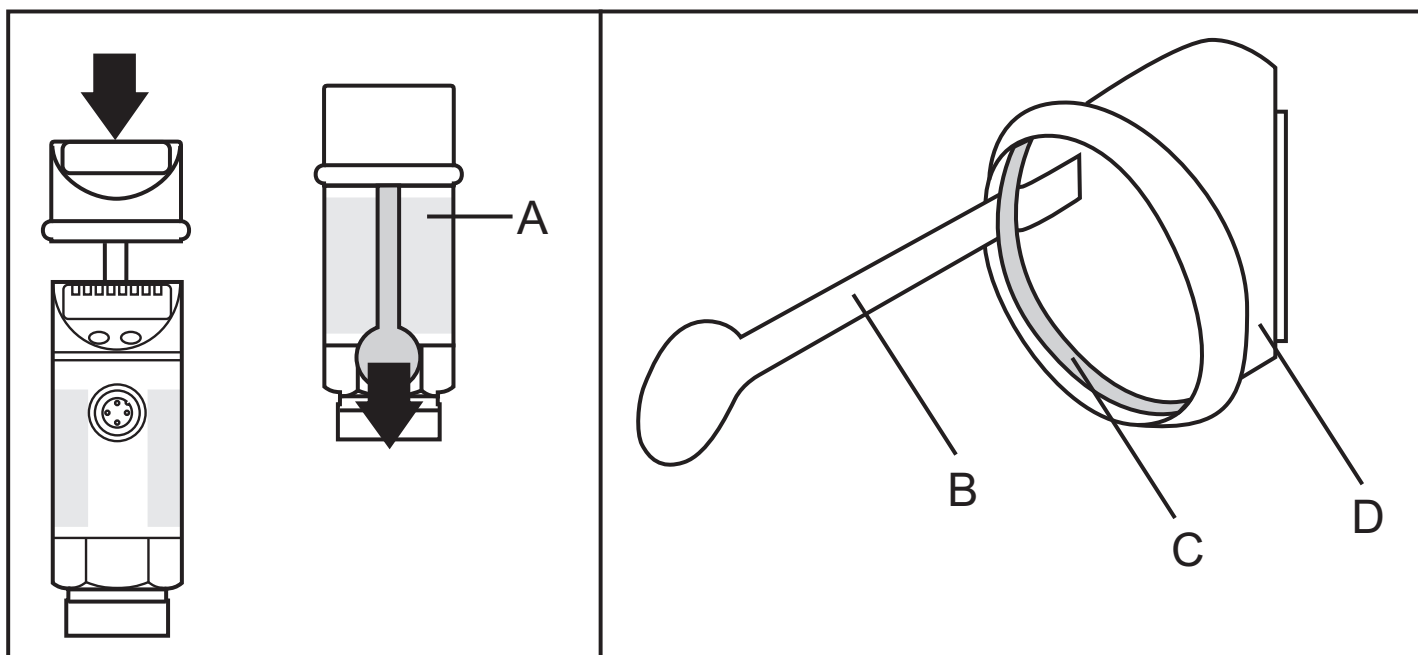

A: label; B: ventilation strip; C: O-ring; D: protective cover

Program the sensor before mounting the protective cover. After mounting the programming buttons will no longer be accessible.

Mounting

- ▶ Make sure that the interior of the protective cover and the sensor head are clean. Slightly grease the O-ring with paste. The paste must be suitable and approved for the application and compatible with the O-ring.
- ▶ Slip the protective cover onto the sensor head. Turn it so that the display of the sensor remains visible.
NOTE: The protective cover must not be slipped over the type label of the sensor. This affects the sealing effect. Reposition the type label, if necessary.
- ▶ Remove the ventilation strip to ensure sealing.

Removal / Remounting

- ▶ Slightly turn the cover and remove it.
- ▶ Insert the ventilation strip before remounting (between the O-ring and the wall of the protective cover). Use the original strip or a stable plastic strip with a strength of max. 0.4 mm.