

Installation instructions  
Welding adapter

**E30407**

**UK**

80284747 / 00 09 / 2019

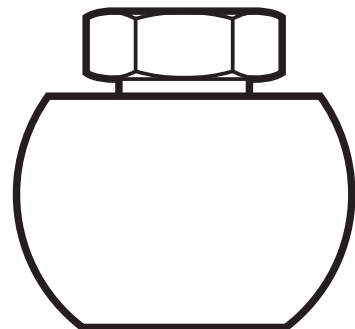

# 1 Items supplied

- Nut
- Clamping ring
- Adapter

# 2 Installation

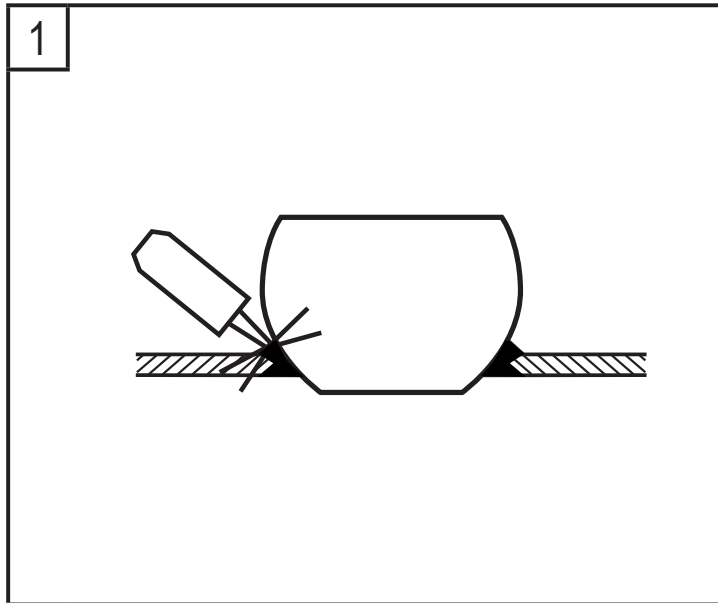

▶ Weld the adapter into the tank / pipe.

**!** The adapter must only be welded by qualified personnel.

▶ Use welding methods suited for the material (high-grade stainless steel 316L/1.4404).

▶ Make sure that the adapter does not warp.

▶ Let the adapter cool down.

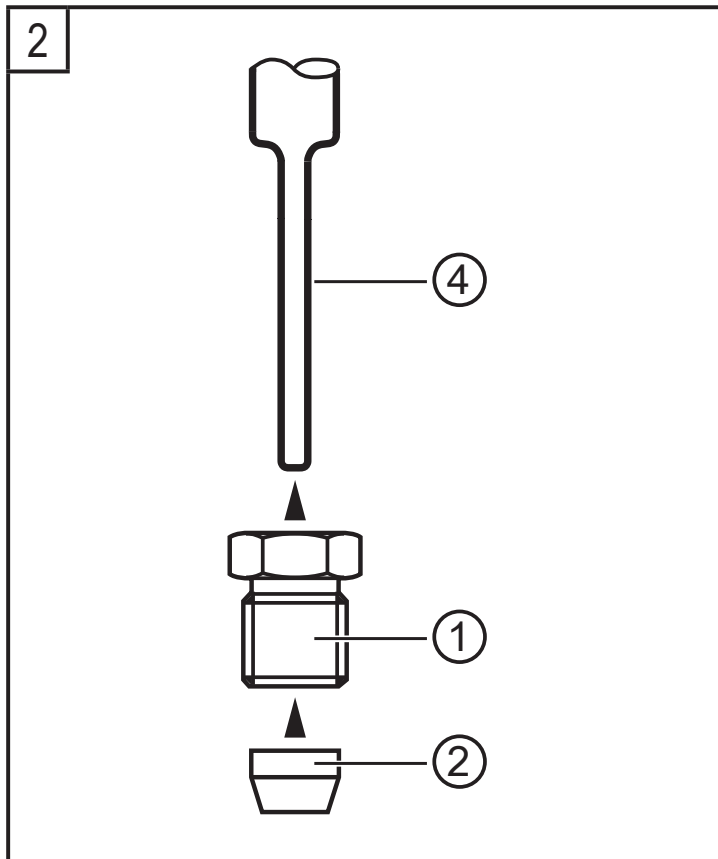

▶ Slide the nut (B) onto the probe of the temperature sensor (4).

▶ Slide the clamping ring (2) onto the probe of the temperature sensor (4).

**!** The chamfered end must be positioned in the direction of the sensor tip.

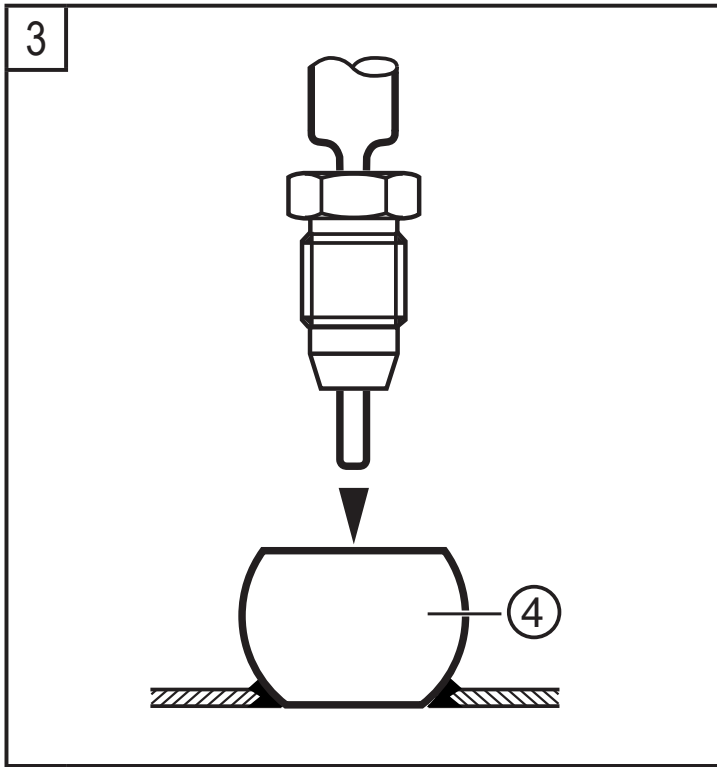

- ▶ Insert the sensor with the attached nut and clamping ring in the adapter (4).
- ▶ Tighten the nut by hand.

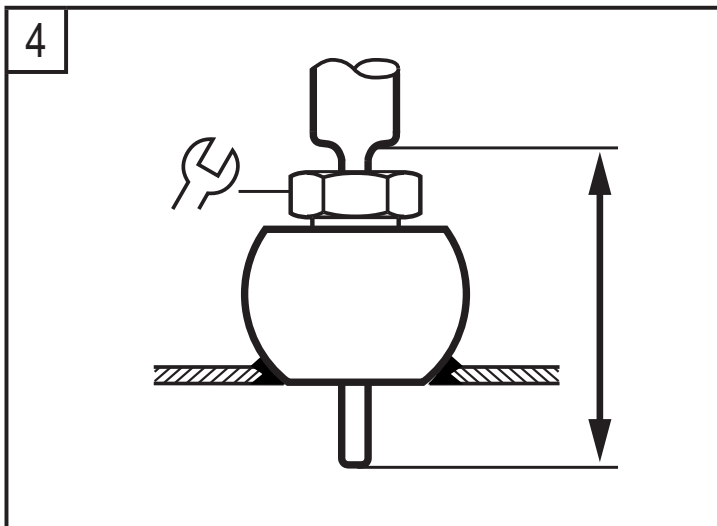

- ▶ Adjust the sensor to the required installation depth.
- ▶ Hold the sensor and use a suitable tool to tighten the nut with a tightening torque of 8-10 Nm.