

Position Sensors

2-WIRE POSITION TRANSMITTER

(rotary motion type; 90 degrees)

Functions & Features

- Detecting rotating angle of a valve actuator or moving positions of other rotating machines and transmitting standard 4 to 20 mA DC proportional to the position
- Light weight and compact design
- High resolution
- Excellent reliability & durability
- Field selectable direct or reverse action
- Rugged enclosure

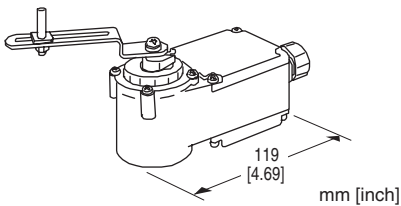

MODEL: VOS2T-R-[1][2][3][4]

ORDERING INFORMATION

- Code number: VOS2T-R-[1][2][3][4]
- Specify a code from below for each of [1] through [4].
(e.g. VOS2T-R-11L0)
- Input angle
- Shipped with input angle adjusted as specified.
If not specified it is adjusted to -45 - 45°.

[1] LEVER

- 0: None
- 1: Effective radius 15 - 40 mm (0.59" - 1.57")
- 2: Effective radius 40 - 130 mm (1.57" - 5.12")
- 3: Effective radius 35 - 80 mm (1.38" - 3.15")

[2] LEVER POSITION

- 1: Upper side
- 2: Lower side

[3] RETURN SPRING

- 0: None
- L: Counterclockwise return (Seen from the lever side)
- R: Clockwise return (Seen from the lever side)

[4] WIRING CONDUIT

- 0: G 1/2
- 1: 1/2" NPT fitting
- 2: G 1/2 with cable connector
- 4: Cables connected (approx. 1 meter or 3.3 ft)

RELATED PRODUCTS

- Link set (model: VOLK)
- When using in combination with link set (model: VOLK), specify the module with lever.

GENERAL SPECIFICATIONS

- Degree of protection:** IP66
(Screw torque for cover: 1.2 - 1.6 N·m)
- Action:** Direct or reverse; field selectable by change of the jumper pins' positions; factory set to direct action
- Wiring conduit:** G 1/2
- Connection:** M3.5 screw terminals (torque 0.8 N·m)
- Materials**
 - Housing:** Cast aluminium
 - Screw terminals:** Nickel-plated steel
 - Cable connector:** Nylon 66
(applicable cable's external dia. 6.5 - 8.5 mm)
 - Lever:** Stainless-steel
 - Painting color:** Silver
- Isolation:** Output to metal housing
- Zero adjustment:** -4.5 - +4.5° of input angle
The Zero indicates such input angle where the transmitter outputs 12 mA.
- Span adjustment:** 45 - 90° of input angle
The Span indicates the absolute difference between such input angle for 4 mA and that for 20 mA.

INPUT SPECIFICATIONS

- Input:** Mechanical rotating angle
- Effective rotating angle:** Approx. -55 - +55° (110°)
- Linearity assured range:** -45 - +45° (90°)
- Input angle adjustment:** Angle for positive and negative with center 0°. (-22.5 - +22.5° to -45 - +45°)
- Stopper strength:** 1.37 N·m (1.011 ft·lbf)
with static load

OUTPUT SPECIFICATIONS

- Output:** 4 - 20 mA DC
- Operational range:** 3.5 - 23 mA DC
- Load resistance v.s. supply voltage:**
Load Resistance (Ω) = (Supply Voltage (V) - 12 (V)) ÷ 0.02 (A) (including leadwire resistance)
(Refer to the graphic on the end of the section)
- Output characteristics:** Proportional to the input angle

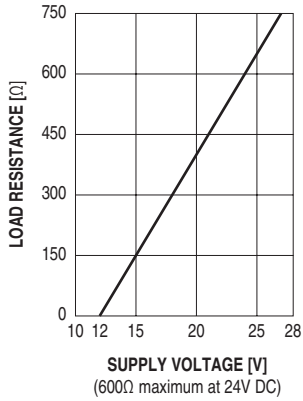

INSTALLATION

Supply voltage: 15 - 28 V DC

Operating temperature: -5 to +60°C (23 to 140°F)

Operating humidity: 30 to 90 % RH (non-condensing inside)

Environment: Protect from strong magnetic field.

Vibration: ≤ 2 G (19.6 m/s²)

Mounting position: All directions

Weight: 550 g (1.21 lb) without lever and cable

PERFORMANCE in percentage of span

Linearity: 1.0 %

Temp. coefficient: ±0.03 %/°C (±0.02 %/°F)

Insulation resistance: ≥ 100 MΩ with 500 V DC

Dielectric strength: 500 V AC @ 1 minute

(output to metal housing)

STANDARDS & APPROVALS

EU conformity:

EMC Directive

EMI EN 61000-6-4

EMS EN 61000-6-2

RoHS Directive

EXTERNAL DIMENSIONS unit: mm [inch]

■ Lever Attached to the Lower Side

- Effective radius 15 – 40 mm
- Effective radius 40 – 130 mm or 35 – 80 mm

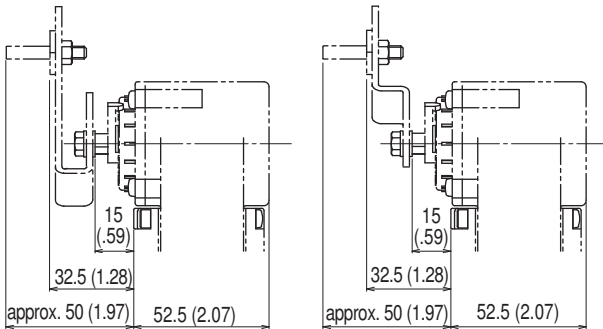

LEVER SIZE mm (inch)

LEVER TYPE	A	B
Effective Radius 15 – 40 mm (.59" – 1.57")	R12 (.47) – R45 (1.77)	54 (2.13)
Effective Radius 40 – 130 mm (1.57" – 5.12")	R38 (1.50) – R132 (5.20)	141 (5.55)
Effective Radius 35 – 80 mm (1.38" – 3.15")	R30 (1.18) – R82.5 (3.25)	91.5 (3.60)

■ Lever Attached to the Upper Side

- Effective radius 40 – 130 mm or 35 – 80 mm

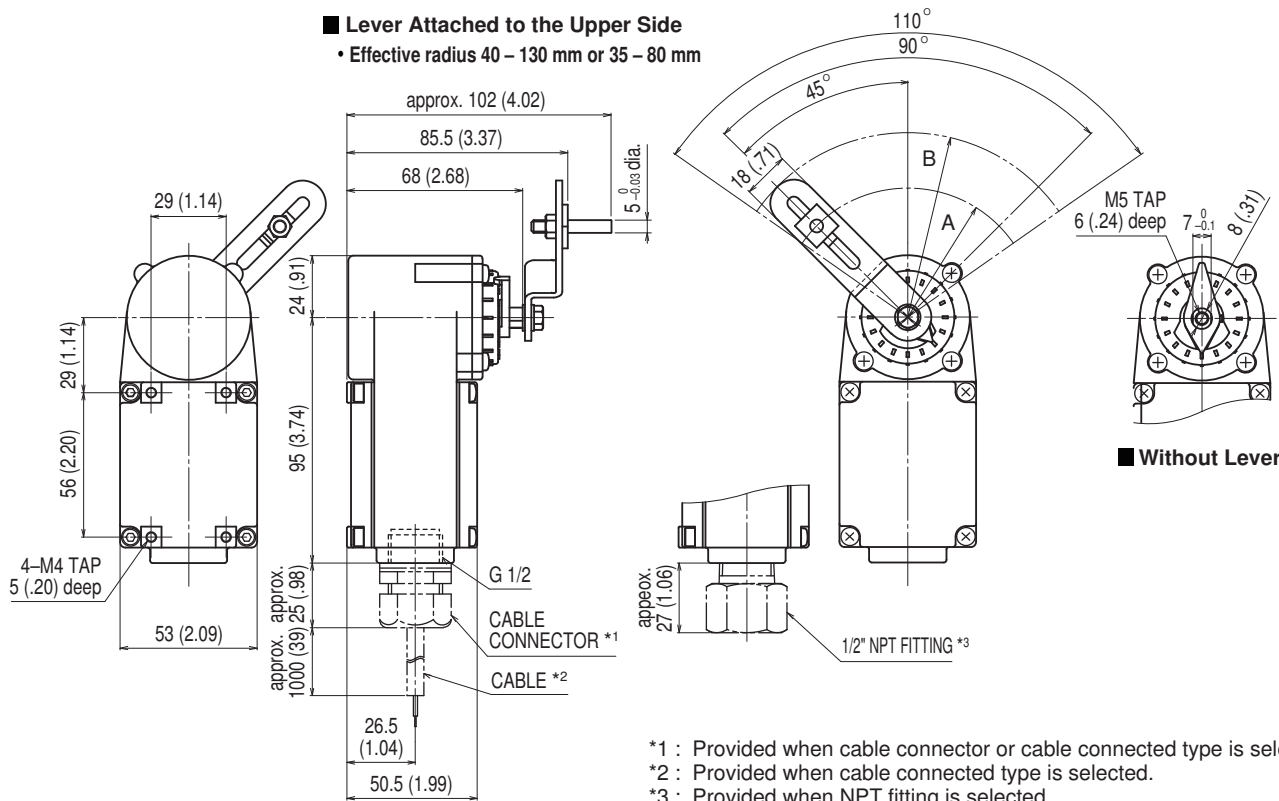

■ Without Lever

- *1 : Provided when cable connector or cable connected type is selected.
- *2 : Provided when cable connected type is selected.
- *3 : Provided when NPT fitting is selected.

• Effective radius 15 – 40 mm

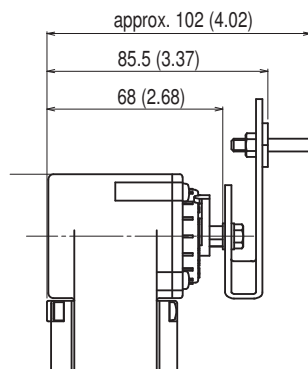

SCHEMATIC CIRCUITRY & CONNECTION DIAGRAM

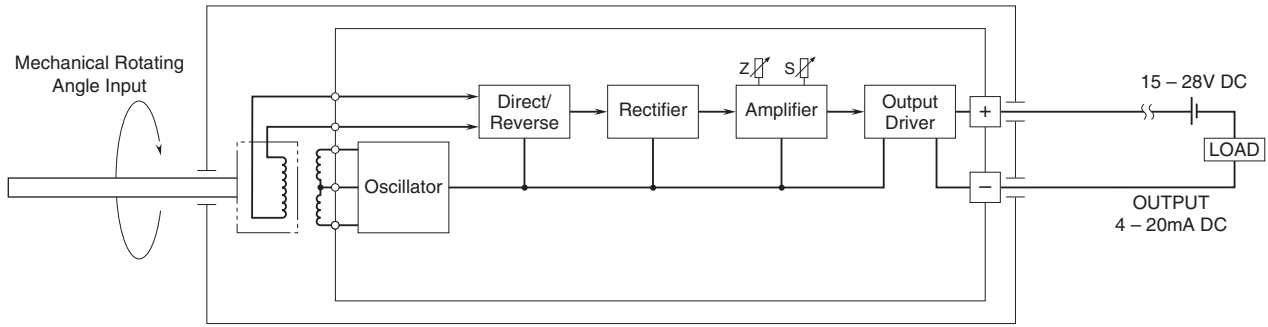

■ Cable Connected Type

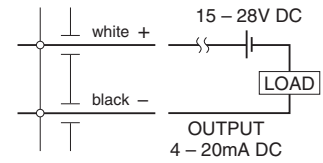

Specifications are subject to change without notice.