



Visualisation; Diagnostics

Easy to Configure

Programming IEC 61131-3

Rapid Installation

## PSEN cs1.13p ATEX

**PILZ**  
THE SPIRIT OF SAFETY

► PSEN sensor technology

This document is the original document.

All rights to this documentation are reserved by Pilz GmbH & Co. KG. Copies may be made for the user's internal purposes. Suggestions and comments for improving this documentation will be gratefully received.

Source code from third-party manufacturers or open source software has been used for some components. The relevant licence information is available on the Internet on the Pilz homepage.

Pilz®, PIT®, PMI®, PNOZ®, Primo®, PSEN®, PSS®, PVIS®, SafetyBUS p®, SafetyEYE®, SafetyNET p®, the spirit of safety® are registered and protected trademarks of Pilz GmbH & Co. KG in some countries.



SD means Secure Digital

<b>Introduction</b> .....	<b>5</b>
Validity of documentation .....	5
Using the documentation .....	5
Definition of symbols .....	5
<b>Safety</b> .....	<b>6</b>
Intended use .....	6
Safety regulations .....	7
Safety assessment .....	7
Additional documents that apply .....	7
Use of qualified personnel .....	7
Warranty and liability .....	8
Disposal .....	8
For your safety .....	8
<b>Unit features</b> .....	<b>9</b>
<b>Function description</b> .....	<b>10</b>
Safety Device Diagnostics .....	11
Operating distances .....	12
Lateral and vertical offset .....	12
<b>Wiring</b> .....	<b>13</b>
Terminal assignment connectors .....	14
<b>Connection to evaluation devices</b> .....	<b>15</b>
<b>Teaching in the actuator</b> .....	<b>21</b>
<b>Installation</b> .....	<b>21</b>
<b>Periodic test</b> .....	<b>24</b>
<b>Adjustment</b> .....	<b>24</b>
<b>Operation</b> .....	<b>24</b>
<b>Dimensions in mm</b> .....	<b>25</b>
<b>Technical details</b> .....	<b>25</b>
Safety characteristic data .....	28
<b>Supplementary data</b> .....	<b>29</b>
Radio approval .....	29
<b>Order reference</b> .....	<b>29</b>
System .....	29
Accessories .....	29

**EC declaration of conformity ..... 31**

## Introduction

### Validity of documentation

This documentation is valid for the product PSEN cs1.13p from Version 2.0.

This operating manual explains the function and operation, describes the installation and provides guidelines on how to connect the product.

### Using the documentation

This document is intended for instruction. Only install and commission the product if you have read and understood this document. The document should be retained for future reference.

### Definition of symbols

Information that is particularly important is identified as follows:



#### **DANGER!**

This warning must be heeded! It warns of a hazardous situation that poses an immediate threat of serious injury and death and indicates preventive measures that can be taken.



#### **WARNING!**

This warning must be heeded! It warns of a hazardous situation that could lead to serious injury and death and indicates preventive measures that can be taken.



#### **CAUTION!**

This refers to a hazard that can lead to a less serious or minor injury plus material damage, and also provides information on preventive measures that can be taken.



#### **NOTICE**

This describes a situation in which the product or devices could be damaged and also provides information on preventive measures that can be taken. It also highlights areas within the text that are of particular importance.



### INFORMATION

This gives advice on applications and provides information on special features.

## Safety

### Intended use

The safety switch is approved for use in potentially explosive atmospheres in accordance with EN 60079-0, EN 60079-7, EN 60079-18, EN 60079-31.

Ex area Group II, Category 3G, Zone 2 (Gas): II 3G Ex ec mc IIC 90°C(T5) Gc and Category 3D, Zone 22 (dust): II 3D Ex mc tc IIIC T90°C Dc.

The safety functions of the safety switch are:

- ▶ Safe shutdown of safety outputs when the actuator is removed beyond the assured release distance  $s_{ar}$  or when the actuator is not detected
- ▶ Remain shut down safely after the actuator has been removed

The safety switch meets the requirements in accordance with:

- ▶ EN 60947-5-3: PDDb with the actuator PSEN cs1.1
- ▶ EN 62061: SIL CL 3
- ▶ EN ISO 13849-1: PL e (Cat. 4)
- ▶ EN ISO 14119: Coding level Low, type 4

The safety switch may only be used with the corresponding actuator PSEN cs1.1.

The safety level PL e (Cat. 4)/SIL CL 3 is only achieved if

- ▶ the safety outputs use 2-channel processing.

The following is deemed improper use in particular

- ▶ Any component, technical or electrical modification to the product,
- ▶ Use of the product outside the areas described in this manual,
- ▶ Use of the product outside the technical details (see [Technical details](#)  25]).



### NOTICE

#### EMC-compliant electrical installation

The product is designed for use in an industrial environment. The product may cause interference if installed in other environments. If installed in other environments, measures should be taken to comply with the applicable standards and directives for the respective installation site with regard to interference.

## Safety regulations

### Safety assessment

Before using a device it is necessary to perform a safety assessment in accordance with the Machinery Directive.

Functional safety is guaranteed for the product as a single component. However, this does not guarantee the functional safety of the overall plant/machine. In order to achieve the required safety level for the overall plant/machine, define the safety requirements for the plant/machine and then define how these must be implemented from a technical and organisational standpoint.

### Additional documents that apply

Please read and take note of the following documents.

#### Only for use of the Safety Device Diagnostics (SDD):

- ▶ Operating manual for the fieldbus module, for example SDD ES ETH or SDD ES PROFIBUS
- ▶ System description "Safety Device Diagnostics"

#### For the use of passive junctions:

- ▶ Operating manual of a passive junction, for example:
  - PSEN ix2 F4 code
  - PSEN ix2 F8 code
  - PDP67 F 4 code
  - PSEN Y junction M12 sensor
  - PSEN Y junction M12 cable

You will need to be conversant with the information in these documents in order to fully understand this operating manual.

### Use of qualified personnel

The products may only be assembled, installed, programmed, commissioned, operated, maintained and decommissioned by competent persons.

A competent person is a qualified and knowledgeable person who, because of their training, experience and current professional activity, has the specialist knowledge required. To be able to inspect, assess and operate devices, systems and machines, the person has to be informed of the state of the art and the applicable national, European and international laws, directives and standards.

It is the company's responsibility only to employ personnel who

- ▶ Are familiar with the basic regulations concerning health and safety / accident prevention,
- ▶ Have read and understood the information provided in the section entitled Safety
- ▶ Have a good knowledge of the generic and specialist standards applicable to the specific application.

### Warranty and liability

All claims to warranty and liability will be rendered invalid if

- ▶ The product was used contrary to the purpose for which it is intended,
- ▶ Damage can be attributed to not having followed the guidelines in the manual,
- ▶ Operating personnel are not suitably qualified,
- ▶ Any type of modification has been made (e.g. exchanging components on the PCB boards, soldering work etc.).

### Disposal

- ▶ In safety-related applications, please comply with the mission time  $T_M$  in the safety-related characteristic data.
- ▶ When decommissioning, please comply with local regulations regarding the disposal of electronic devices (e.g. Electrical and Electronic Equipment Act).

### For your safety



#### WARNING!

#### Loss of safety function due to manipulation of the interlocking device

Manipulation of the interlocking device may lead to serious injury and death.

- You should prevent any possibility of the interlocking device being manipulated through the use of a spare actuator.
- Keep the substitute actuator in a safe place and protect it from unauthorised access.
- If spare actuators are used, these must be installed as described in [Installation](#) [ 21].
- If the original actuators are replaced with substitute actuators, the original actuators must be destroyed before disposal.



#### WARNING!

#### Ignition spark from cable separator/connector within the potentially explosive area can trigger an explosion

When the cable separators/connectors are used within the potentially explosive area, sparks can be caused and lead to an explosion.

- Make sure that the cable separators/connectors are used only within the potentially explosive area.

- ▶ Do not remove the connector's protective cap until you are just about to connect the unit. This will prevent potential contamination.
- ▶ Switch off the supply voltage before disconnecting the plug-in connection.
- ▶ Make sure that when connecting or separating the connector the pollution degree 1 or 2 is maintained.

- ▶ The connector should be protected from accidental loosening (e.g. using a cable tie).
- ▶ The IP protection type (see [Technical details \[25\]](#)) has been determined in accordance with DIN EN 60529 with a safety switch that is as new.

### Unit features

- ▶ Transponder technology for presence detection
- ▶ Pilz coding type: Coded
- ▶ Dual-channel operation
- ▶ 2 safety inputs for series connection of multiple safety switches
- ▶ 2 safety outputs
- ▶ Safety Device Diagnostics (SDD)
  - Safety Device Diagnostics can be used to poll sensor information, to perform actions and to read configuration parameters
  - Manipulation protection in accordance with ISO 14119 (chap. 7.2.d) is possible by verifying the short name of the actuator through the controller via SDD communication
- ▶ Diagnostic input for Y1 for Safety Device Diagnostics (SDD)
- ▶ Signal output/diagnostic output Y32 for Safety Device Diagnostics
- ▶ LED display for:
  - State of the actuator
  - State of the inputs
  - Supply voltage/fault
- ▶ 4 directions of actuation

### Function description

The safety outputs may have a high or low signal, depending on the position of the actuator and the signal status of the inputs.

In a safe condition the safety outputs are in the OFF state.

**Electrical states of the inputs and outputs (when switch is ready for operation: Power/Fault LED is green):**

Actuator in the re-sponse range	Safety input S11	Safety input S21	Safety out-put 12	Safety out-put 22	Signal out-put Y32 (without use of the SDD)
Yes	High	High	High	High	High
Yes	Low	Low	Low	Low	High
No	x	x	Low	Low	Low
Yes	High	Low	High	Low	High
Yes	Low	High	Low	High	High

x: High or low signal

#### Feasibility monitoring for safety inputs S11 and S21

- ▶ If one safety input switches from high to low, while the other safety input remains high, an unequal status is displayed: **Input LED flashes yellow**
- ▶ If this safety input switches back from low to high, while the other safety input remains high, a feasibility error is displayed and a partial operation lock is triggered: **Input LED flashes yellow**

A switch to a high signal will only lead to normal switch operation if both inputs had a low signal. From this moment on, the switch to high may occur (partial operation lock see [Error display \[📖 24\]](#)).

#### ▶ Diagnostic input Y1

If a fieldbus module of the SDD is used, the diagnostic input Y1 is automatically activated and data is read.

If no fieldbus module of the SDD is used, the diagnostic input Y1 is not used.

#### ▶ Signal output/diagnostic output Y32

The status of the actuator is output. If a fieldbus module of the SDD is used, the signal output/diagnostic output for the writing of data is activated.

### Block diagram

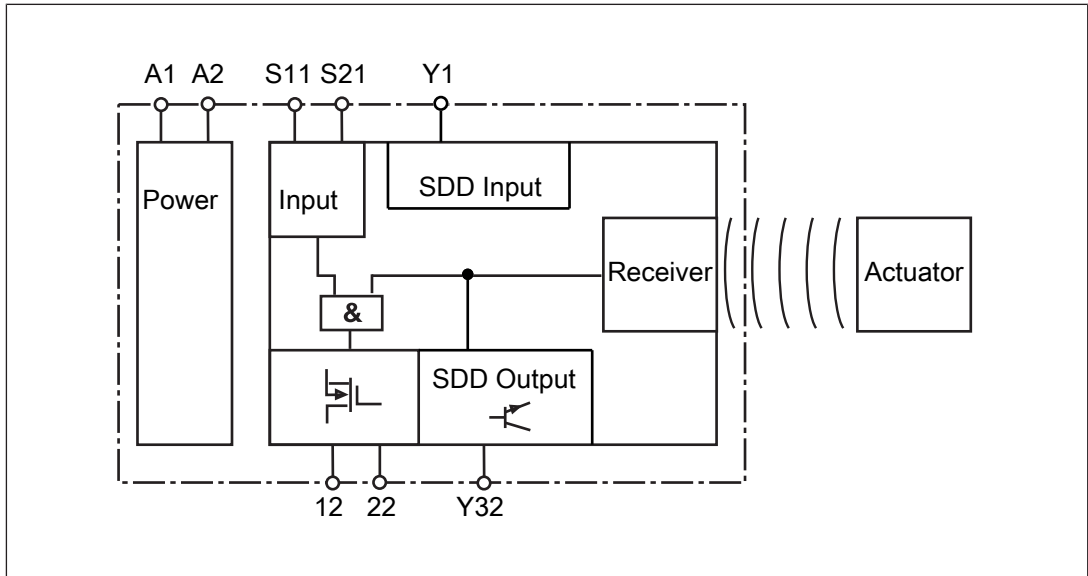

### Safety Device Diagnostics

Safety Device Diagnostics is an option that can be selected independently of the safety-related wiring.

When using the Safety Device Diagnostics, up to 16 sensors connected in series can be connected as a subscriber to a fieldbus module.

The communication of the sensors with the fieldbus module is automatically built up again with **each** new supply of the supply voltage. As a result, a sensor can be exchanged, e.g. when servicing, without the need for special measures.

An exchange can be detected via the fieldbus module e.g. through the serial number.

► With Safety Device Diagnostics there are the following diagnostic options for the fieldbus module:

- Poll information of the sensors (examples: what sensor in the series has switched, at what point could there be an open circuit in the series connection)
- Read configuration parameters of the sensors (examples: Number of remaining teach-in processes, serial number of the switch)
- Perform actions (example: poll updated actuator name)

The results of the sensor diagnostics can be checked already during the installation phase via the display in the fieldbus module, without the need to connect the fieldbus module to the network.

► With Safety Device Diagnostics there are the following diagnostic options for the fieldbus module for simple wiring:

- Information is passed on via the fieldbus module directly to the network
- Mappings of the signal outputs to the sensor are automated by the SDD.

This prevents wiring errors and an expansion or reduction of the sensors is possible without the need to change existing wiring.

- Wiring in accordance with IP20: Rapid installation in the control cabinet is enabled.

- Wiring in accordance with IP67: Various passive junctions can be used (see [Order references for accessories](#) [29]) to connect several sensors with only one cable from the field in the control cabinet.

Further information on Safety Device Diagnostics can be found in [Additional documents that apply](#) [7].

**Operating distances**

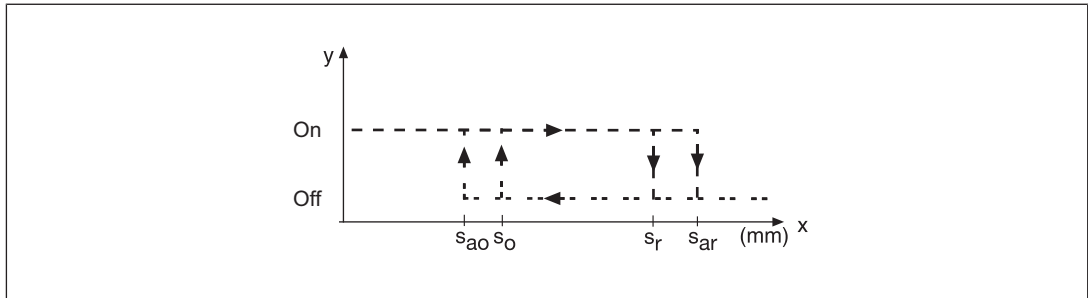

**Legend:**

- ▶  $S_{ao}$ : Assured operating distance: 15 mm
- ▶  $S_o$ : Typical operating distance: 21 mm
- ▶  $S_r$ : Typical release distance: 32 mm
- ▶  $S_{ar}$ : Assured release distance: 40 mm

**Lateral and vertical offset**

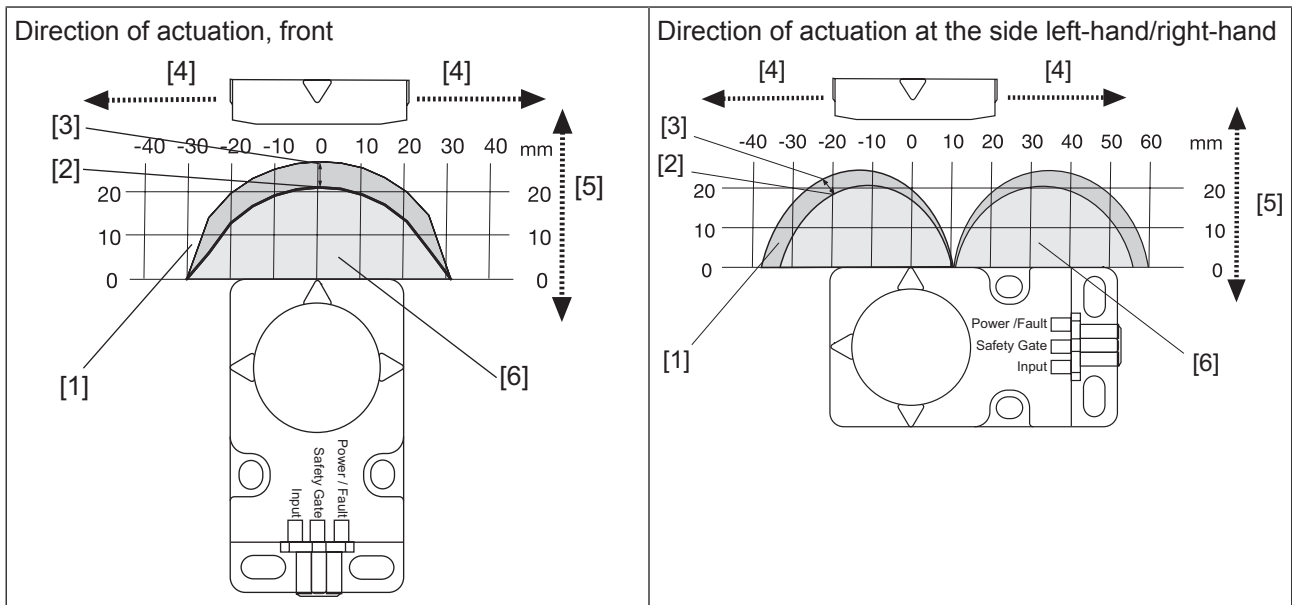

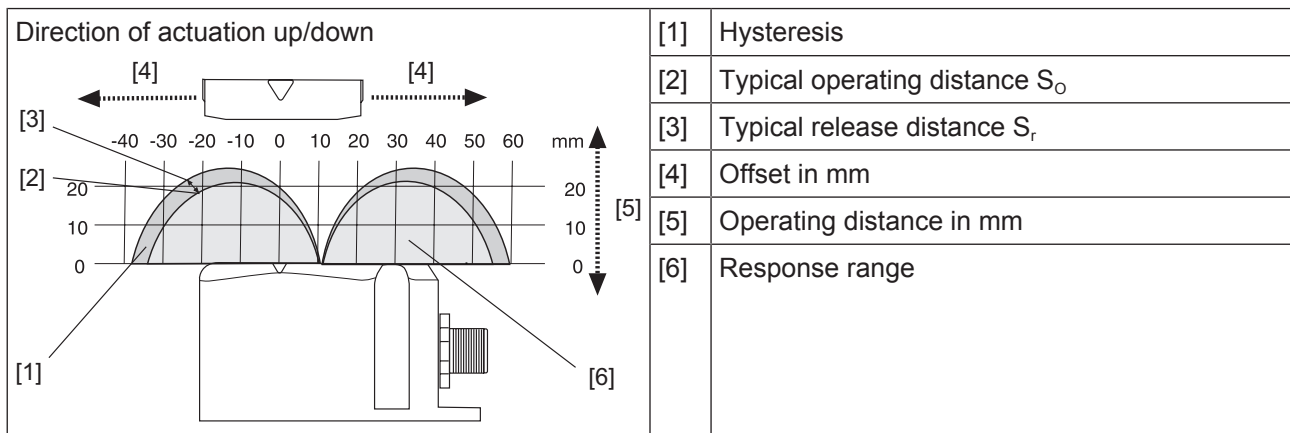

## Wiring

Please note:

- ▶ Information given in the [Technical details \[25\]](#) must be followed.
- ▶ The max. cable length  $l_{max}$  in the input circuit is calculated from
  - the max. cable capacitance at the safety outputs (see [Technical data \[25\]](#)).
  - the minimum permitted supply voltage at the sensor (19.2 V).
- ▶ When the safety inputs of the safety switch are controlled by an upstream device, and they are not wired with 24 V,
  - They must be monitored for shorts across the contacts in dependence of the Performance Level or SIL level to be achieved **or**
  - The faults at the safety inputs that can occur by shorts across contact will have to be excluded by suitable measures (e.g. wiring in accordance with EN 602041).
- ▶ The power supply must meet the regulations for extra low voltages with protective separation (SELV, PELV).
- ▶ The inputs and outputs of the safety switch must have a protective separation to voltages over 60 VDC.



### INFORMATION

Only use safety relays with a 24 VDC supply voltage. Safety relays with a wide-range power supply or in AC device versions have internal potential isolation and are not suitable as evaluation devices.

- ▶ The supply voltage to the safety switch must be protected with a 2 A to 4 A quick-acting fuse.
- ▶ Ensure the wiring and EMC requirements of EN 60204-1 are met.
- ▶ Refer to the notes on wiring in EN 60079-14.
- ▶ When connecting in series, consider the requirements of manipulation protection and the protection against bypassing or from overriding the safety switch (EN ISO 14119).
- ▶ Ensure that the connector of the safety switch in the EX area is not removed or inserted.
- ▶ Any metallic parts (also accessories) must be connected to the equipotential bonding in case of a risk of charging.

**Terminal assignment connectors**

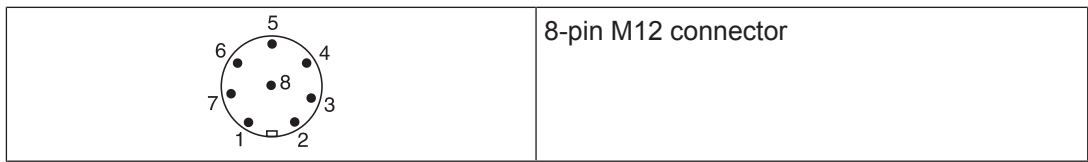

PIN	Connection designation	Function	Wire colour
1	S21	Input, channel 2	white
2	A1	+24 VUB	brown
3	12	Output, channel1	green
4	22	Output, channel2	yellow
5	Y32	Signal output/diagnostic output	grey
6	S11	Input, channel 1	pink
7	A2	0 V UB	blue
8	Y1	Diagnostics input	red

The wire colour also applies for the cable available from Pilz as an accessory.

### Connection to evaluation devices

Make sure that the selected evaluation device has the following properties:

- ▶ 2-channel with feasibility monitoring
- ▶ OSSD signals are evaluated

Please note:

- ▶ The use of Safety Device Diagnostics is described in the System Description "Safety Device Diagnostics".



**CAUTION!**

**Do not connect the signal output to 0 V!**

If the signal output Y32 is connected to 0 V, the safety switch may be damaged as a result. Connect the signal output Y32 to a consumer, e.g. to the input on a control system, or leave the signal output unconnected. Also note the max. current (see [Technical details \[25\]](#)).

#### Connection diagram, single connection without SDD

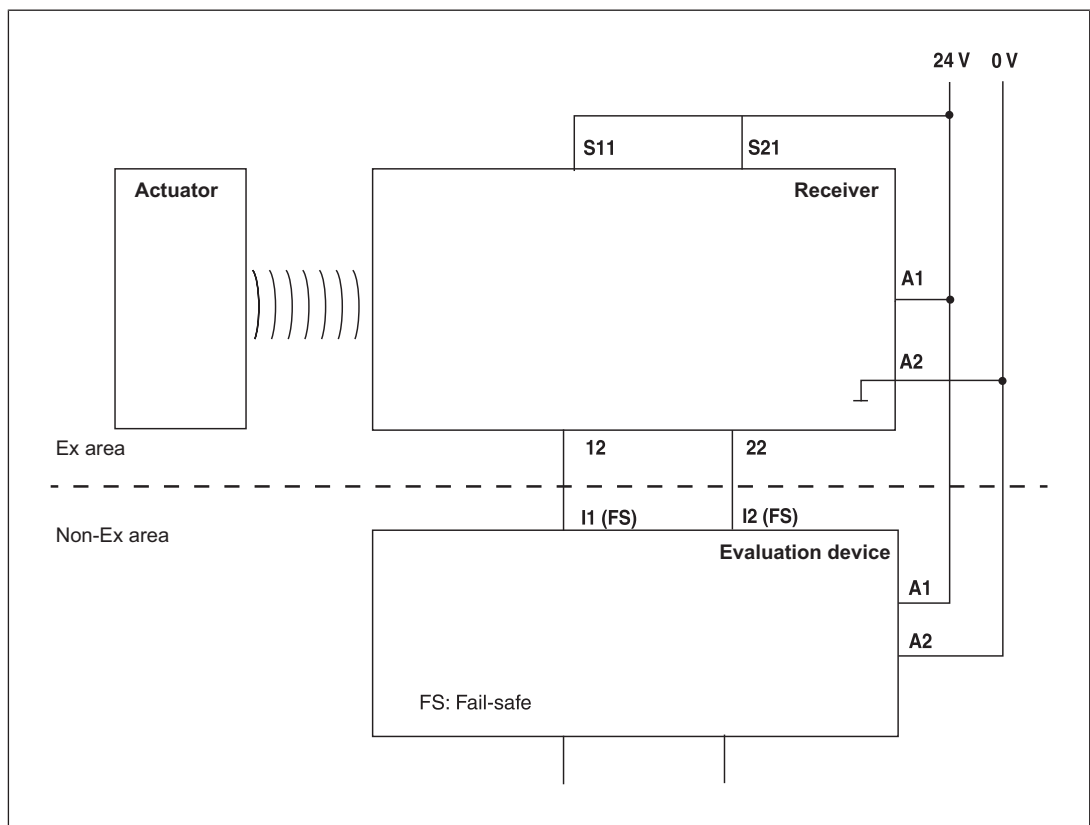

**Connection diagram, single connection with SDD**

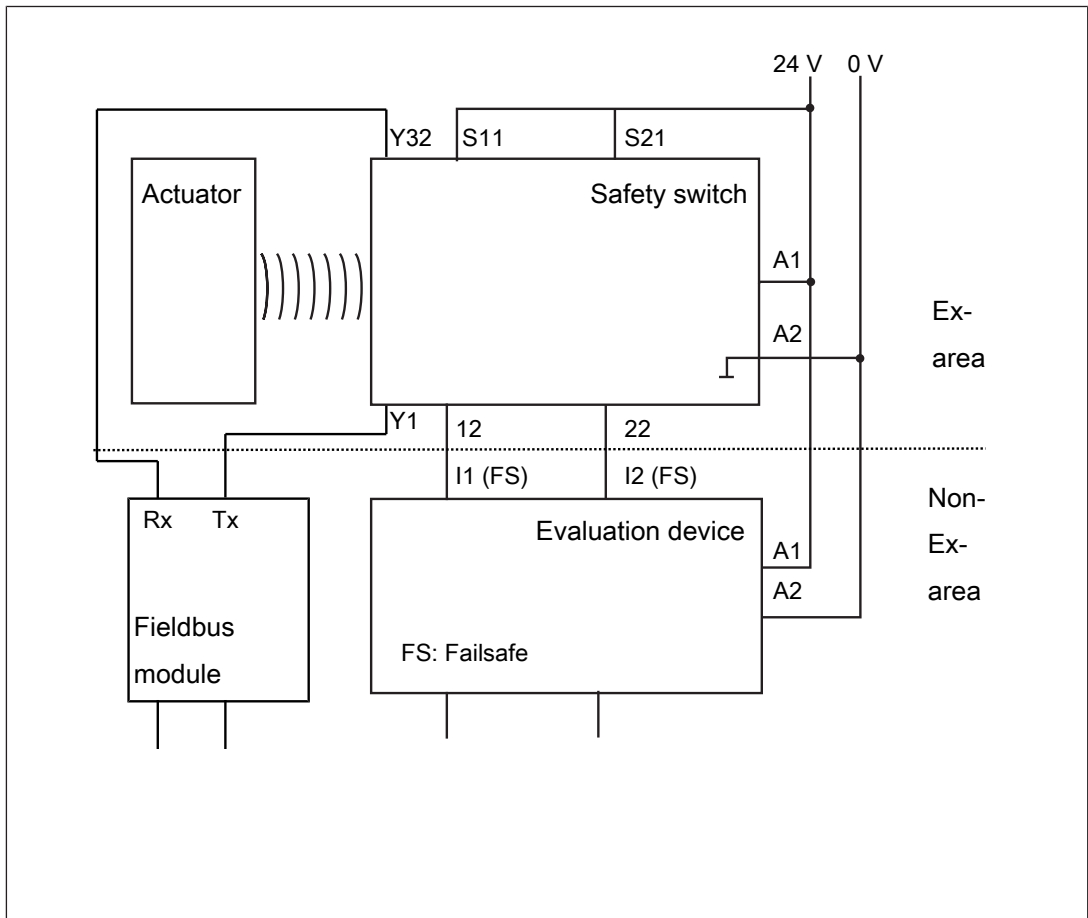

**Series connection**

The safety sensors PSENcode are also suitable for series connection with other sensors.

Maximum number of PSENcode sensors switched in series connections for SIL CL 3 using SDD

- ▶ PSENcode large design (PSEN cs1.xp - cs2.xp): 8

When using other SDD-compatible sensors, the number must be recalculated.

In practice, the maximum possible number will be limited by the following parameters, among others:

- ▶ The required SIL level (e.g. SIL CL 3),
- ▶ the required performance level (e.g. PL e (Cat. 4)),
- ▶ the maximum delay or risk time permitted by the application.

Ensure there is sufficient supply voltage, taking inrush currents and fusing into consideration.



**CAUTION!**

**Extension of delay-on de-energisation**

When several (n) devices are connected in series, the delay-on de-energisation time adds with the number of interconnected safety switches.

The may. delay-on de-energisation is composed of

max. delay-on de-energisation actuator

+ (n-1) x max. delay-on de-energisation of the inputs

+ delay-on de-energisation of the evaluation device

▶ When making series connections using SDD, only use the following passive junctions.

- PSEN ix2 F4 code
- PSEN ix2 F8 code
- PSEN Y junction M8-M12/M12 PIGTAIL
- PSEN Y junction M12-M12/M12 PIGTAIL
- PSEN Y junction M12 SENSOR
- PSEN Y junction M12 cable channel

Connection diagram, series connection without SDD

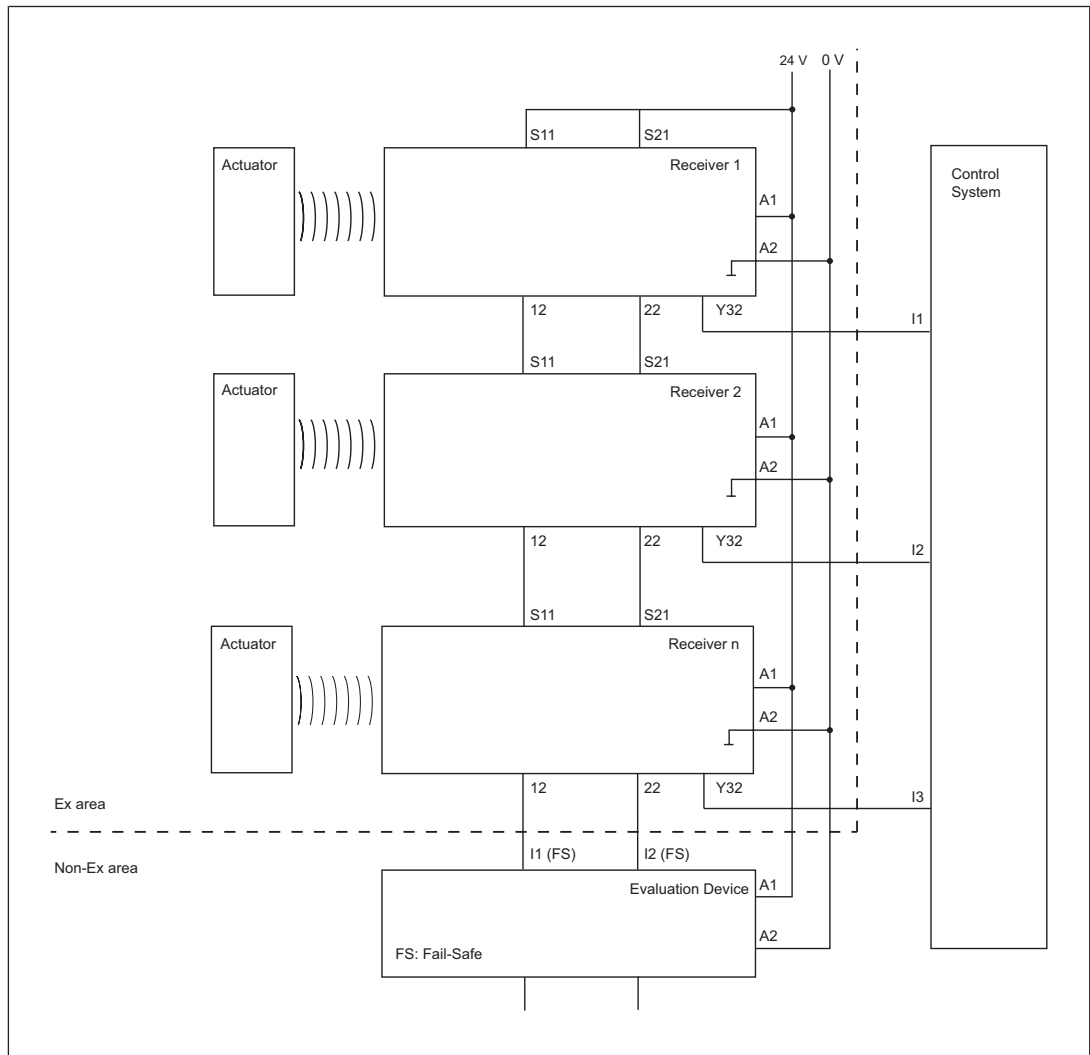

Connection diagram, series connection with SDD

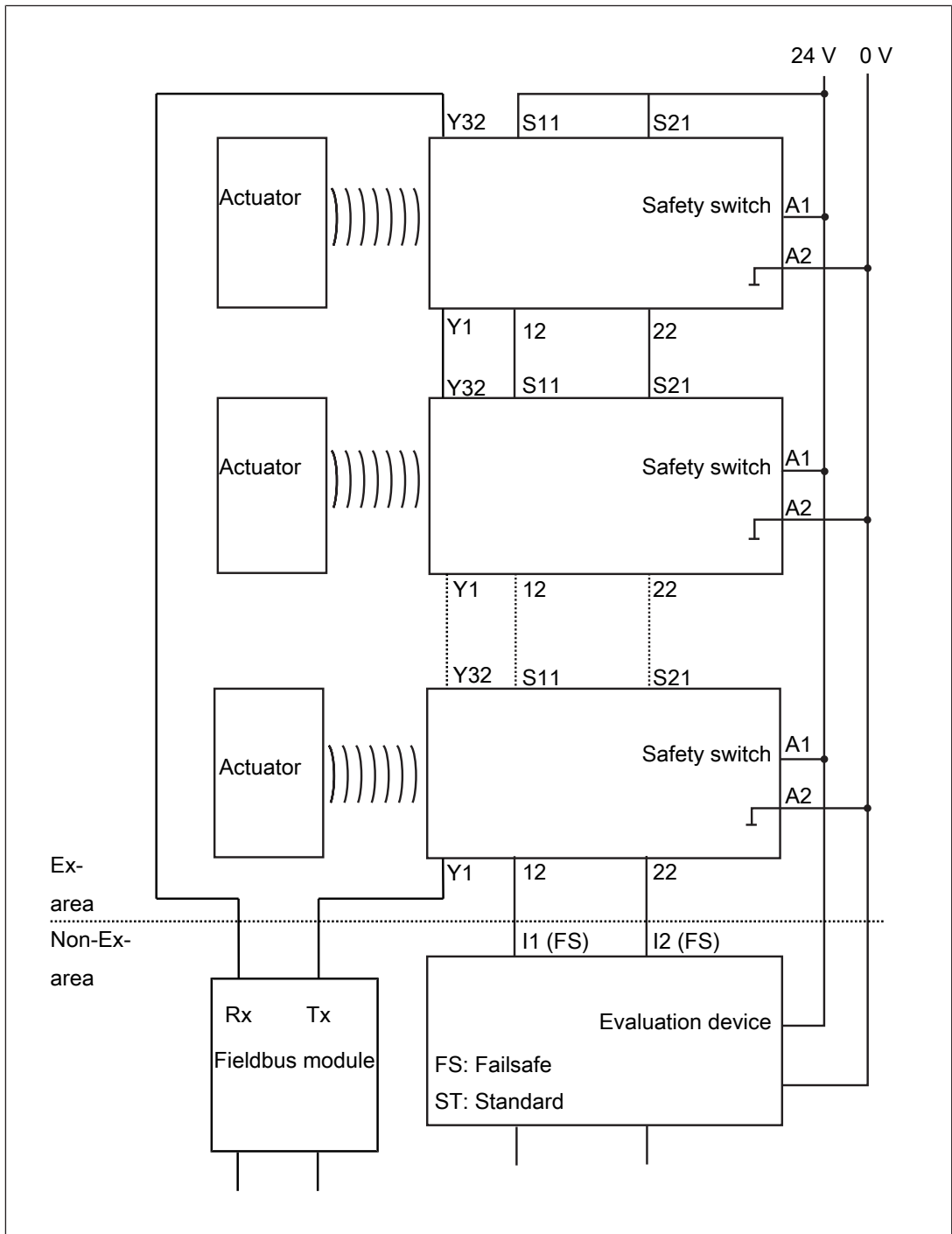

**Connection to Pilz evaluation devices**

Suitable Pilz evaluation devices are, for example:

- ▶ PNOZelog for safety gate monitoring
- ▶ PNOZpower for safety gate monitoring
- ▶ PNOZsigma for safety gate monitoring
- ▶ PNOZ X for safety gate monitoring

- ▶ PNOZmulti for safety gate monitoring  
Configure the switch in the PNOZmulti Configurator with switch type 3.
- ▶ PSS for safety gate monitoring with standard function block SB064, SB066 or FS\_Safety Gate
- ▶ PSSuniversal PLC for safety gate monitoring with function block FS\_SafetyGate

The correct connection to the respective evaluation device is described in the operating manual for the evaluation device. Make sure that the connection is made in accordance with the specifications in the operating manual for the selected evaluation device.

The connections to two evaluation devices are shown on the following pages, by way of example:

- ▶ PNOZ s3 and
- ▶ PNOZmulti

**PNOZ s3**

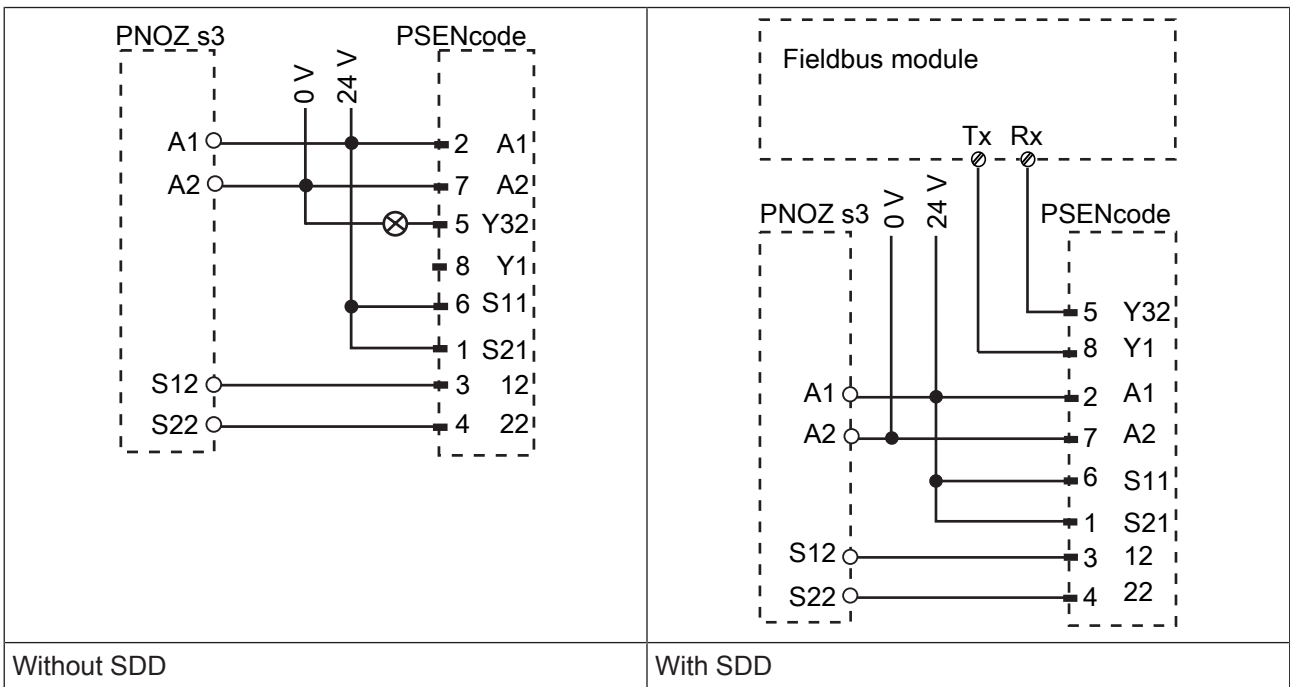

**PNOZmulti**

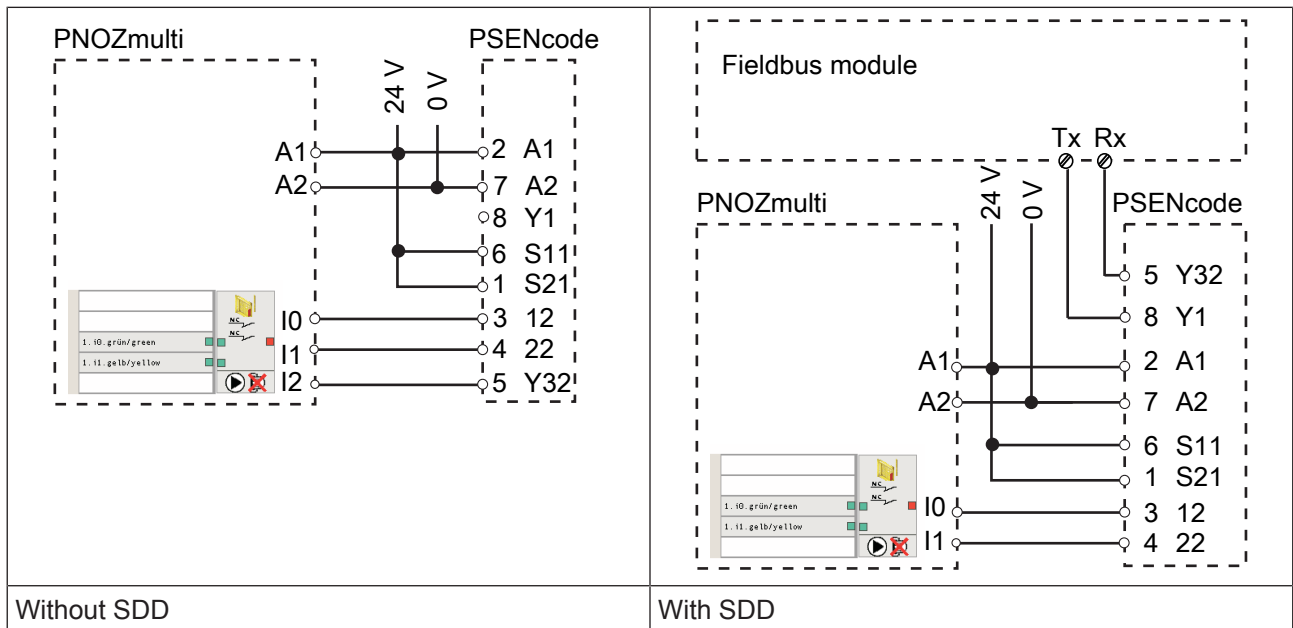

**Legend:**

I0	Input OSSD
I1	Input OSSD
I2	Signal input

**Teaching in the actuator**

Any approved Pilz actuator is detected as soon as it is brought into the response range.

**Installation**



**DANGER!**

**Risk of sparking due to electrostatic charging of the safety switch in the potentially explosive area**

In order to avoid electrostatic charging, clean the safety switch with a damp cloth.

Do not expose the safety switch to high charge-generating processes.

**DANGER!**

**Risk of damage due to mechanical load. Live components on the safety switch in the potentially explosive area may become exposed**

Protect the edges of the safety switch base from shock. This can be achieved by full face installation (see [Installation](#) [📖 21]).

Protect the plug-in connector on the safety switch from shock (e.g by using the PSEN cs1/2 bracket cable fix, see [Order references for accessories](#) [📖 29]).

Please note the information given in the "Installation" section.

- ▶ Any metallic parts (also accessories) must be connected to the equipotential bonding in case of a risk of charging.
- ▶ Make sure that the earthing is in accordance with the specifications in EN 60079-14.

**CAUTION!**

**Potential loss of safety function due to changed device properties**

The unit's properties may be affected if installed in an environment containing electrically or magnetically conductive material.

- Please check the operating distances and the assured release distance.

- ▶ The safety switch and actuator should be installed opposite each other in parallel.
  - Make sure that the actuator is aligned to the marking on the sensor that guarantees the operating distance required by the plant design (see [Operating distances](#) [📖 12]).
- ▶ Safety switches and actuators should be permanently secured using M5 safety screws with a flat head (e.g. M5 cheese-head or pan head screws).
- ▶ Protect the actuator from contamination.
- ▶ Torque setting: Please note the information provided under [Technical details](#) [📖 25].
- ▶ The distance between two safety switches must be maintained (see [Technical details](#) [📖 25]).
- ▶ Make sure that the safety switch and actuator cannot be used as an end stop.
- ▶ Please note the installation measures in accordance with EN ISO 14119 for a safety switch design 4 and with level of coding Low.
- ▶ For simpler installation, the mounting brackets (see [Order reference for Accessories](#) [📖 29]) can be used.
- ▶ If using angled connector plugs, note the defined angle of the cable routing.

**CAUTION!****Possible loss of the safety function by changing the release distance  $S_{ar}$  with non-flush installation**

Installing the safety switch non-flush within electrically or magnetically conductive material, the value for the assured release distance  $S_{ar}$  can change.

- Check the assured release distance  $S_{ar}$ .

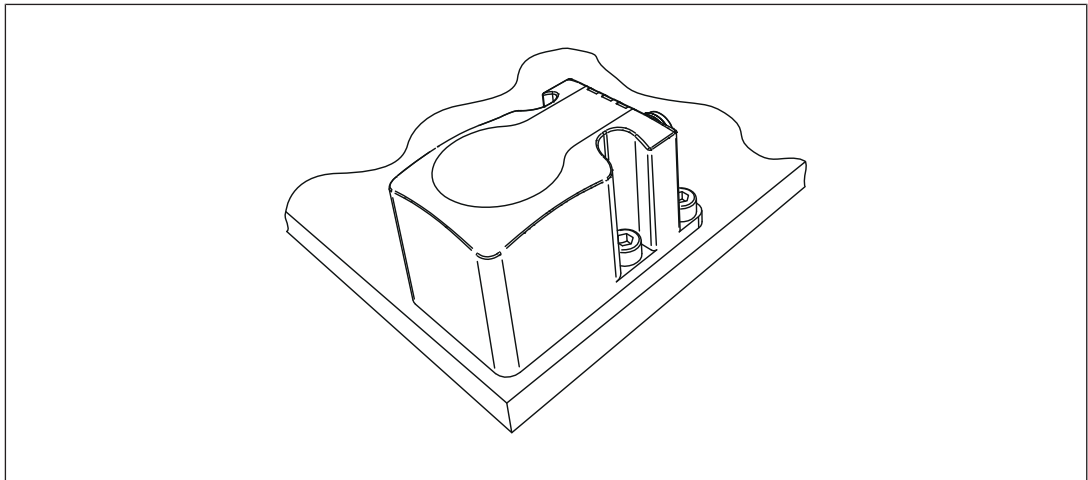

Installation example:

The full face of the safety switch is installed on the subplate.

As a result, the edges of the safety switch base are protected from shock.



**Procedure:**

Fig.: Sensing faces on the sensor

1. Drill holes (for M5 screws) in the mounting surface to secure the actuator and sensor (see [Dimensions in mm](#)  25]).
2. Use a screw to fix the sensor to the mounting surface.

Make sure that the sensor marking that is be used for operation can be operated using the actuator from the right side.

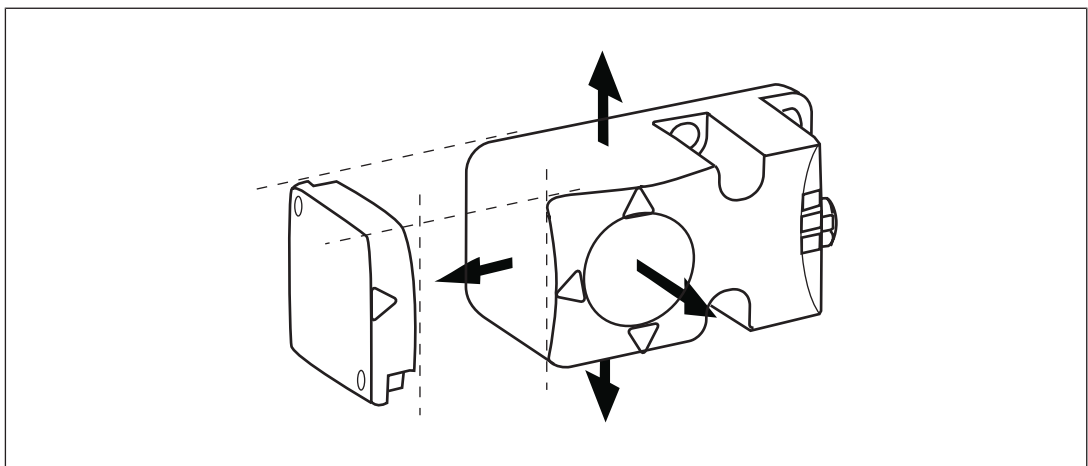

3. Do not fully tighten the second screw on the safety switch.

4. Use a screw to fix the actuator to the mounting surface.  
Make sure that the actuator with the printed side points towards the marking on the sensor.
5. Do not fully tighten the second screw on the actuator.
6. Align the safety switch and tighten the screws.
7. Align the actuator and tighten the screws.

### Periodic test

- ▶ Make sure that the work is **not** performed in an explosive atmosphere.
- ▶ Carry out a monthly function test on the safety switch and actuator.
- ▶ Always test the function with a connected evaluation device.
- ▶ The safety function may only be checked by qualified personnel.
- ▶ Refer to the notes on checking the safety switch in EN 60079-17 and EN 60079-19.

### Adjustment

- ▶ The stated operating distances (see [Technical details](#)  25) only apply when the safety switch and actuator are installed facing each other in parallel. Operating distances may deviate if other arrangements are used.
- ▶ Note the maximum permitted lateral and vertical offset (see [Operating distances](#)  12] and [Lateral and vertical offset](#)  12]).

### Operation



#### NOTICE

The safety function should be checked after initial commissioning and each time the plant/machine is changed. The safety functions may only be checked by qualified personnel.

#### Status indicators:

- ▶ "Power/Fault" LED lights up green: The unit is ready for operation
- ▶ "Safety Gate" LED lights up yellow: Actuator is within the response range
- ▶ "Input" LED lights up yellow: There is a high signal at both inputs

#### Fault indicator:

- ▶ "Input" LED lights up yellow: the signal switches from high to low at one input, while a high signal remains on the other input (partial operation).  
Remedy: Open both channels of the input circuit.
- ▶ "Power/Fault" LED lights up red: Error message  
Remedy: Rectify fault and interrupt power supply.

Please note the different times for

- ▶ The switch-on delay after UB is applied

- ▶ The recovery time of the sensor and evaluation device.

## Dimensions in mm

### Safety switch

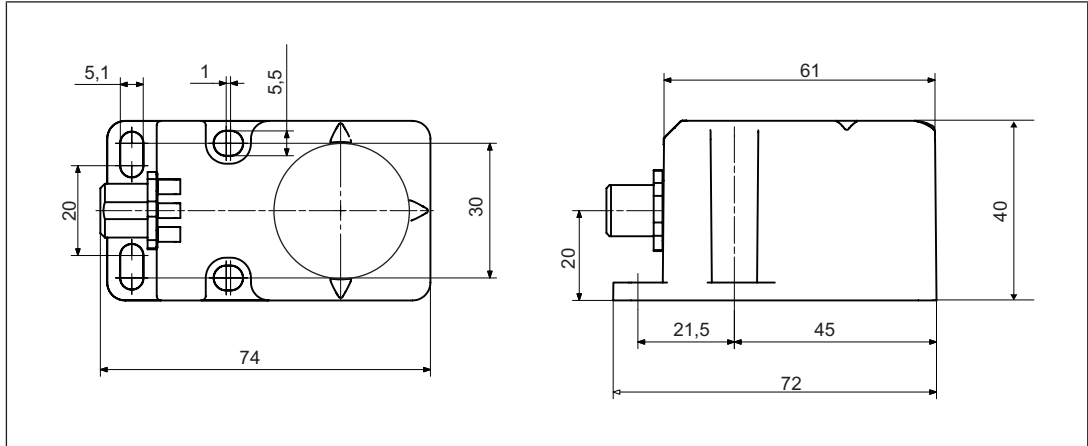

### Actuator

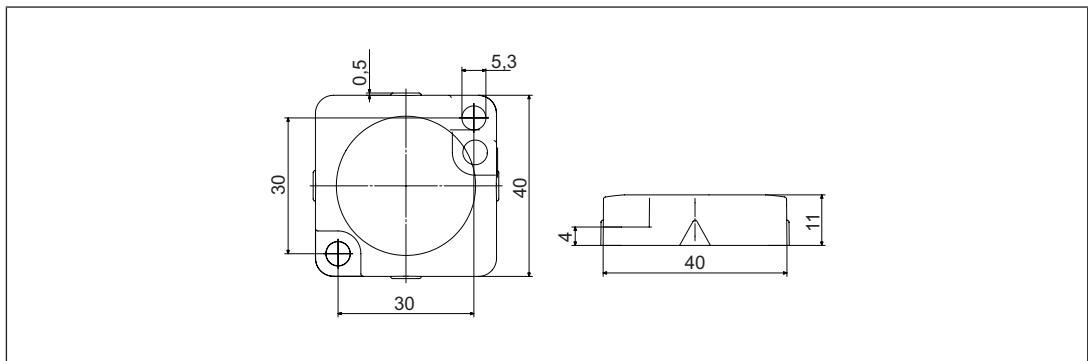

## Technical details

### General

Certifications	<b>ATEX, CE, EAC (Eurasian), ECOLAB, FCC, IC, TÜV, cULus Listed, electrosuisse</b>
Sensor's mode of operation	<b>Transponder</b>
Coding level in accordance with EN ISO 14119	<b>Low</b>
Design in accordance with EN ISO 14119	<b>4</b>
Classification in accordance with EN 60947-5-3	<b>PDDB</b>
Pilz coding type	<b>Coded</b>

### Transponder

Frequency band	<b>122 kHz - 128 kHz</b>
Max. transmitter output	<b>7 dBm</b>

**Electrical data**

Supply voltage	
Voltage	<b>24 V</b>
Kind	<b>DC</b>
Voltage tolerance	<b>-20 %/+20 %</b>
Output of external power supply (DC)	<b>2 W</b>
Max. inrush current at UB	<b>0,12 A</b>
Max. switching frequency	<b>3 Hz</b>
Max. cable capacitance at the safety outputs	
No-load, PNOZ with relay contacts	<b>40 nF</b>
PNOZmulti, PNOZelog, PSS	<b>70 nF</b>
No-load current	<b>50 mA</b>

**Inputs**

Number	<b>2</b>
Voltage at inputs	<b>24 V DC</b>
Input current range	<b>5 mA</b>
Max. overall cable resistance R <sub>lmax</sub>	
Single-channel at UB DC	<b>1000 Ohm</b>

**Semiconductor outputs**

OSSD safety outputs	<b>2</b>
Signal outputs	<b>1</b>
Switching current per output	<b>500 mA</b>
Breaking capacity per output	<b>12 W</b>
Potential isolation from system voltage	<b>No</b>
Short circuit-proof	<b>yes</b>
Residual current at outputs	<b>10 µA</b>
Voltage drop at OSSDs	<b>3,5 V</b>
Lowest operating current	<b>0 mA</b>
Utilisation category in accordance with EN 60947-1	<b>DC-12</b>

**Times**

Test pulse duration, safety outputs	<b>450 µs</b>
Switch-on delay	
after UB is applied	<b>1 s</b>
Inputs typ.	<b>13 ms</b>
Inputs max.	<b>20 ms</b>
Actuator typ.	<b>60 ms</b>
Actuator max.	<b>150 ms</b>
Delay-on de-energisation	
Inputs typ.	<b>15 ms</b>
Inputs max.	<b>20 ms</b>
Actuator typ.	<b>40 ms</b>
Actuator max.	<b>260 ms</b>
Risk time in accordance with EN 60947-5-3	<b>260 ms</b>
Supply interruption before de-energisation	<b>20 ms</b>
Simultaneity, channel 1 and 2 max.	<b>∞</b>

<b>Environmental data</b>	
ATEX certification	<b>SEV 12 ATEX 0122 X</b>
ATEX category, gas	<b>II 3G Ex ec mc IIC 90°C(T5) Gc</b>
ATEX category, dust	<b>II 3D Ex mc tc IIIC T90°C Dc</b>
Application area	<b>X: -25°C ≤ ta ≤ +40°C</b>
Ambient temperature	
In accordance with the standard	<b>EN 60068-2-14</b>
Temperature range	<b>-25 - 40 °C</b>
Max. at max. operating height	<b>+40 °C</b>
Max. at max. operating height <2000 m	<b>+40 °C</b>
Storage temperature	
In accordance with the standard	<b>EN 60068-2-1/-2</b>
Climatic suitability	
In accordance with the standard	<b>EN 60068-2-78</b>
Humidity	<b>93 % r. h. at 40 °C</b>
Max. operating height above sea level	<b>4000 m</b>
EMC	<b>EN 60947-5-3</b>
Vibration	
In accordance with the standard	<b>EN 60947-5-2</b>
Frequency	<b>10 - 55 Hz</b>
Amplitude	<b>1 mm</b>
Shock stress	
In accordance with the standard	<b>EN 60947-5-2</b>
Acceleration	<b>30g</b>
Duration	<b>11 ms</b>
Airgap creepage	
Overvoltage category	<b>III</b>
Pollution degree	<b>3</b>
Rated insulation voltage	<b>75 V</b>
Rated impulse withstand voltage	<b>0,8 kV</b>
Protection type	
Housing	<b>IP67</b>
<b>Mechanical data</b>	
Actuator 1	<b>PSEN cs1.1</b>
Operating distances	
Assured operating distance Sao	<b>15 mm</b>
Typical operating distance So	<b>21 mm</b>
Assured release distance Sar	<b>40 mm</b>
Typical release distance Sr	<b>32 mm</b>
Repetition accuracy switching distances	<b>10 %</b>
Change of operating distance with temperature changes	<b>+0,01mm/°C</b>
Typ. Hysteresis	<b>3 mm</b>
Min. distance between safety switches	<b>400 mm</b>
Sensor flush installation in accordance with EN 60947-5-2	<b>Yes, follow installation guidelines</b>

Mechanical data	
Connection type	<b>M12, 8-pin male connector</b>
Material	
Top	<b>PBT</b>
Max. torque setting for fixing screws	<b>1 Nm</b>
Dimensions	
Height	<b>75 mm</b>
Width	<b>40 mm</b>
Depth	<b>40 mm</b>
Actuator dimensions	
Height	<b>11 mm</b>
Width	<b>40 mm</b>
Depth	<b>40 mm</b>
Weight of safety switch	<b>130 g</b>
Weight of actuator	<b>20 g</b>
Weight	<b>150 g</b>

Where standards are undated, the 2016-10 latest editions shall apply.

#### Safety characteristic data



#### NOTICE

You must comply with the safety characteristic data in order to achieve the required safety level for your plant/machine.

Operating mode	EN ISO 13849-1: 2015	EN ISO 13849-1: 2015	EN 62061 SIL CL	EN 62061 PFH <sub>D</sub> [1/h]	IEC 61511 SIL	IEC 61511 PFD	EN ISO 13849-1: 2015 T <sub>M</sub> [year]
	PL	Category					
2-ch. OSSD	<b>PL e</b>	<b>Cat. 4</b>	<b>SIL CL 3</b>	<b>4,10E-09</b>	<b>–</b>	<b>1,10E-04</b>	<b>20</b>

Explanatory notes for the safety-related characteristic data:

- ▶ The SIL CL value in accordance with EN 62061 corresponds to the SIL value in accordance with EN 61508.
- ▶ T<sub>M</sub> is the maximum mission time in accordance with EN ISO 13849-1. The value also applies as the retest interval in accordance with EN 61508-6 and IEC 61511 and as the proof test interval and mission time in accordance with EN 62061.

All the units used within a safety function must be considered when calculating the safety characteristic data.



#### INFORMATION

A safety function's SIL/PL values are **not** identical to the SIL/PL values of the units that are used and may be different. We recommend that you use the PAScal software tool to calculate the safety function's SIL/PL values.

## Supplementary data

### Radio approval

USA/Canada

**FCC** ID: VT8-PSENCs1  
**IC:** 7482A-PSENCs1

FCC/IC-Requirements:

This product complies with Part 15 of the FCC Rules and with Industry Canada licence-exempt RSS standards.

Operation is subject to the following two conditions:

- 1) this product may not cause harmful interference, and
- 2) this product must accept any interference received, including interference that may cause undesired operation.

Changes or modifications made to this product not expressly approved by Pilz may void the FCC authorization to operate this equipment.

NOTE: This equipment has been tested and found to comply with the limits for a Class A digital device, pursuant to Part 15 of the FCC Rules. These limits are designed to provide reasonable protection against harmful interference when the equipment is operated in a commercial environment. This equipment generates, uses, and can radiate radio frequency energy and, if not installed and used in accordance with the instruction manual, may cause harmful interference to radio communications. Operation of this equipment in a residential area is likely to cause harmful interference in which case the user will be required to correct the interference at his own expense.

Le présent produit est conforme aux CNR d'Industrie Canada applicables aux appareils radio exempts de licence. L'exploitation est autorisée aux deux conditions suivantes:

- (1) le produit ne doit pas produire de brouillage, et
- (2) l'utilisateur de le produit doit accepter tout brouillage radioélectrique subi, même si le brouillage est susceptible d'en compromettre le fonctionnement.

### Order reference

#### System

Product type	Features	Connection type	Order no.
PSEN cs1.13p/PSEN cs1.1	Safety switch with transponder technology, coded, with actuator with assured operating distance 15 mm	8-pin M12 connector	540 005
PSEN cs1.1	Actuator with transponder technology		540 080

#### Accessories

#### Installation materials

Product type	Features	Order no.
PSEN bracket	Mounting bracket	532 110
PSEN mag/cs bracket straight	Mounting aid	532 111
PSEN screw M5x10 10pcs	Safety screws made from stainless steel with one-way slot	540 311
PSEN screw M5x20 10pcs	Safety screws made from stainless steel with one-way slot	540 312

PSEN cs1/2 bracket cable fix	Mechanical protection against defeat, protecting against unauthorised cable disconnection or damage for safety switches PSENcode cs1/2, PSENcode cs5/6 M12, PSENslock	532 112
------------------------------	--	---------

**Cable**

Product type	Connection 1	Connection 2	Length	Order no.
PSEN cable M12-8sf	Straight, M12, 8-pin, socket	Open cable	3 m	540 319
			5 m	540 320
			10 m	540 321
			20 m	540 333
			30 m	540 326
PSEN cable M12-8af	Angled, M12, 8-pin, socket	Open cable	3 m	540 322
			5 m	540 323
			10 m	540 324
			30 m	540 325
PSEN cable M12-8sf M12-8sm	straight, M12, 8-pin, socket	Straight, M12, 8-pin, pin	2 m	540 340
			5 m	540 341
			10	540 342
			20 m	540 343
			30 m	540 344

**Series connection**

Product type	Connection X1	Connection X2	Connec- tion X3	Order no.
PSEN Y junction M12 SENSOR	M12, 8-pin, pin	M12, 8-pin, socket	M12, 8- pin, socket	540 315
PSEN Y junction M12 cable channel	M12, 8-pin, pin	M12, 8-pin, socket	M12, 8- pin, socket	540 316
PSEN T junction M12	M12, 8-pin, socket	M12, 8-pin, pin	M8, 4-pin, pin	540 331
PSEN Y junction M8-M12/ M12 PIGTAIL	M12, 8-pin, socket	M12, 8-pin, pin	M8, 8-pin, socket	540 337
PSEN Y junction M12-M12/ M12 PIGTAIL	M12, 8-pin, socket	M12, 8-pin, pin	M12, 8- pin, socket	540 338
PDP67 F 4 code	Decentralised passive junction			773 603
PDP67 F 4 code VA	Decentralised passive junction, V2A ring nut			773 613

### Safety Device Diagnostics

Product type	Features	Connection type	Order no.
PSEN ix2 F4 code	Interface for connecting max. 4 PSEN safety sensors	Spring-loaded terminal	535 111
PSEN ix2 F8 code	Interface for connecting max. 8 PSEN safety sensors	Spring-loaded terminal	535 112
SDD ES ETH	Fieldbus module Modbus/TCP for Safety Device Diagnostics	Spring-loaded terminal	540 130
SDD ES Profibus	Fieldbus module Profibus for Safety Device Diagnostics	Spring-loaded terminal	540 132
SDD ES Profinet	Fieldbus module for Safety Device Diagnostics	Spring-loaded terminal	540 138

### EC declaration of conformity

This product/these products meet the requirements of the following directives of the European Parliament and of the Council.

- ▶ 2006/42/EC on machines
- ▶ 2014/34/EU (ATEX)
- ▶ 2014/53/EC on radio equipment

The complete EC Declaration of Conformity is available on the Internet at [www.pilz.com/downloads](http://www.pilz.com/downloads).

Representative: Norbert Fröhlich, Pilz GmbH & Co. KG, Felix-Wankel-Str. 2, 73760 Ostfildern, Germany

# ► Support

Technical support is available from Pilz round the clock.

## Americas

### Brazil

+55 11 97569-2804

### Canada

+1 888-315-PILZ (315-7459)

### Mexico

+52 55 5572 1300

### USA (toll-free)

+1 877-PILZUSA (745-9872)

## Asia

### China

+86 21 60880878-216

### Japan

+81 45 471-2281

### South Korea

+82 31 450 0680

## Australia

+61 3 95600621

## Europe

### Austria

+43 1 7986263-0

### Belgium, Luxembourg

+32 9 3217575

### France

+33 3 88104000

### Germany

+49 711 3409-444

### Ireland

+353 21 4804983

### Italy, Malta

+39 0362 1826711

## Scandinavia

+45 74436332

## Spain

+34 938497433

## Switzerland

+41 62 88979-30

## The Netherlands

+31 347 320477

## Turkey

+90 216 5775552

## United Kingdom

+44 1536 462203

## You can reach our international hotline on:

+49 711 3409-444

support@pilz.com

Pilz develops environmentally-friendly products using ecological materials and energy-saving technologies. Offices and production facilities are ecologically designed, environmentally-aware and energy-saving. So Pilz offers sustainability, plus the security of using energy-efficient products and environmentally-friendly solutions.

*Energy*  
saving by Pilz



Pilz GmbH & Co. KG  
Felix-Wankel-Straße 2  
73760 Ostfildern, Germany  
Tel.: +49 711 3409-0  
Fax: +49 711 3409-133  
info@pilz.com  
www.pilz.com

**PILZ**  
THE SPIRIT OF SAFETY

CMSE®, IndurANET p®, PAS4000®, PASscal®, PASconfig®, Pilz®, PIT®, PLID®, PMCPprime®, PMCPprotect®, PMCIendo®, PMD®, PMi®, PNOZ®, Pirmo®, PSEN®, PSENi®, PSS®, PVIS®, SafetyBUS SafetyEYE®, SafetyNET p®, THE SPIRIT OF SAFETY® are registered and protected trademarks of Pilz GmbH & Co. KG in some countries. We would point out that product features mentioned in the details stated in this document, depending on the status at the time of publication and the scope of the equipment. We accept no responsibility for the validity, accuracy and entirety of the text and graphics presented in this information. Please contact our Technical Support if you have any questions.