



## PSEN cs4.2n

**PILZ**  
THE SPIRIT OF SAFETY

- ▶ PSEN sensor technology

This document is the original document.

All rights to this documentation are reserved by Pilz GmbH & Co. KG. Copies may be made for the user's internal purposes. Suggestions and comments for improving this documentation will be gratefully received.

Source code from third-party manufacturers or open source software has been used for some components. The relevant licence information is available on the Internet on the Pilz homepage.

Pilz®, PIT®, PMI®, PNOZ®, Primo®, PSEN®, PSS®, PVIS®, SafetyBUS p®, SafetyEYE®, SafetyNET p®, the spirit of safety® are registered and protected trademarks of Pilz GmbH & Co. KG in some countries.



SD means Secure Digital

<b>Introduction</b> .....	<b>5</b>
Validity of documentation .....	5
Using the documentation .....	5
Definition of symbols .....	5
<b>Safety</b> .....	<b>6</b>
Intended use .....	6
Safety regulations .....	7
Safety assessment .....	7
Use of qualified personnel .....	7
Warranty and liability .....	7
Disposal .....	7
For your safety .....	8
<b>Unit features</b> .....	<b>8</b>
<b>Function description</b> .....	<b>9</b>
Basic function .....	9
Block diagram .....	9
Operating distances .....	10
Lateral and vertical offset .....	10
<b>Wiring</b> .....	<b>12</b>
Pin assignment, connector and cable .....	12
<b>Connection to evaluation devices</b> .....	<b>13</b>
<b>Teaching in the actuator</b> .....	<b>15</b>
<b>Installation</b> .....	<b>15</b>
General .....	15
Safety switch .....	15
Actuator cs2.1 or cs4.1 .....	16
Actuator cs3.1 low profile .....	17
Align safety switch and actuator .....	21
<b>Adjustment</b> .....	<b>21</b>
<b>Operation</b> .....	<b>22</b>
<b>Dimensions in mm</b> .....	<b>23</b>
Safety switch .....	23
Actuator .....	24

<b>Technical details safety switch</b> .....	<b>26</b>
<b>Technical details actuator</b> .....	<b>29</b>
<b>Classification according to ZVEI, CB24I</b> .....	<b>31</b>
<b>Safety characteristic data</b> .....	<b>32</b>
<b>Supplementary data</b> .....	<b>33</b>
Radio approval.....	33
<b>Order reference</b> .....	<b>33</b>
Safety switch.....	33
Actuator .....	33
Complete systems .....	33
Accessories .....	34
<b>EC declaration of conformity</b> .....	<b>35</b>

## Introduction

### Validity of documentation

This documentation is valid for the product PSEN cs4.2n. It is valid until new documentation is published.

This operating manual explains the function and operation, describes the installation and provides guidelines on how to connect the product.

### Using the documentation

This document is intended for instruction. Only install and commission the product if you have read and understood this document. The document should be retained for future reference.

### Definition of symbols

Information that is particularly important is identified as follows:



#### **DANGER!**

This warning must be heeded! It warns of a hazardous situation that poses an immediate threat of serious injury and death and indicates preventive measures that can be taken.



#### **WARNING!**

This warning must be heeded! It warns of a hazardous situation that could lead to serious injury and death and indicates preventive measures that can be taken.



#### **CAUTION!**

This refers to a hazard that can lead to a less serious or minor injury plus material damage, and also provides information on preventive measures that can be taken.



#### **NOTICE**

This describes a situation in which the product or devices could be damaged and also provides information on preventive measures that can be taken. It also highlights areas within the text that are of particular importance.



### INFORMATION

This gives advice on applications and provides information on special features.

## Safety

### Intended use

The safety functions of the safety switch are:

- ▶ Safe shutdown of safety outputs when the actuator is removed beyond the assured release distance  $s_{ar}$  or when the actuator is not detected
- ▶ Remain shut down safely after the actuator has been removed

The safety switch meets the requirements in accordance with:

- ▶ EN 60947-5-3: PDDb with one of the approved actuators
- ▶ EN 62061: SIL CL 3
- ▶ EN ISO 13849-1: PL e (Cat. 4)
- ▶ EN ISO 14119: Coding level High, type 4

The safety switch may only be used with one of the approved actuators.

The safety level PL e (Cat. 4)/SIL CL 3 is only achieved if

- ▶ the safety outputs use 2-channel processing.

The following is deemed improper use in particular

- ▶ Any component, technical or electrical modification to the product,
- ▶ Use of the product outside the areas described in this manual,
- ▶ Use of the product outside the technical details (see [Technical details](#)  26]).



### NOTICE

#### EMC-compliant electrical installation

The product is designed for use in an industrial environment. The product may cause interference if installed in other environments. If installed in other environments, measures should be taken to comply with the applicable standards and directives for the respective installation site with regard to interference.

Approved actuators:

- ▶ PSEN cs4.1
- ▶ PSEN cs2.1
- ▶ PSEN cs4.1 low profile glue
- ▶ PSEN cs4.1 low profile screw

## Safety regulations

### Safety assessment

Before using a device it is necessary to perform a safety assessment in accordance with the Machinery Directive.

Functional safety is guaranteed for the product as a single component. However, this does not guarantee the functional safety of the overall plant/machine. In order to achieve the required safety level for the overall plant/machine, define the safety requirements for the plant/machine and then define how these must be implemented from a technical and organisational standpoint.

### Use of qualified personnel

The products may only be assembled, installed, programmed, commissioned, operated, maintained and decommissioned by competent persons.

A competent person is a qualified and knowledgeable person who, because of their training, experience and current professional activity, has the specialist knowledge required. To be able to inspect, assess and operate devices, systems and machines, the person has to be informed of the state of the art and the applicable national, European and international laws, directives and standards.

It is the company's responsibility only to employ personnel who

- ▶ Are familiar with the basic regulations concerning health and safety / accident prevention,
- ▶ Have read and understood the information provided in the section entitled Safety
- ▶ Have a good knowledge of the generic and specialist standards applicable to the specific application.

### Warranty and liability

All claims to warranty and liability will be rendered invalid if

- ▶ The product was used contrary to the purpose for which it is intended,
- ▶ Damage can be attributed to not having followed the guidelines in the manual,
- ▶ Operating personnel are not suitably qualified,
- ▶ Any type of modification has been made (e.g. exchanging components on the PCB boards, soldering work etc.).

### Disposal

- ▶ In safety-related applications, please comply with the mission time  $T_M$  in the safety-related characteristic data.
- ▶ When decommissioning, please comply with local regulations regarding the disposal of electronic devices (e.g. Electrical and Electronic Equipment Act).

### For your safety



#### **WARNING!**

#### **Loss of safety function due to manipulation of the interlocking device**

Manipulation of the interlocking device may lead to serious injury and death.

- You should prevent any possibility of the interlocking device being manipulated through the use of a spare actuator.
- Keep the substitute actuator in a safe place and protect it from unauthorised access.
- If spare actuators are used, these must be installed as described in [Installation](#) [ 15].
- If the original actuators are replaced with substitute actuators, the original actuators must be destroyed before disposal.

- ▶ Do not remove the connector's protective cap until you are just about to connect the unit. This will prevent potential contamination.

### Unit features

- ▶ Transponder technology for presence detection
- ▶ Pilz coding type: uniquely coded
- ▶ Dual-channel operation
- ▶ 2 safety outputs
- ▶ LED display for:
  - State of the actuator
  - Supply voltage/fault
- ▶ 1 direction of actuation
- ▶ 5-pin M12 male connector

## Function description

### Basic function

The safety outputs may have a high or low signal, depending on the position of the actuator.

In a safe condition the safety outputs are in the OFF state.

State of the outputs:

Actuator in the response range	Safety output 12	Safety output 22
Yes	High	High
No	Low	Low

### Block diagram

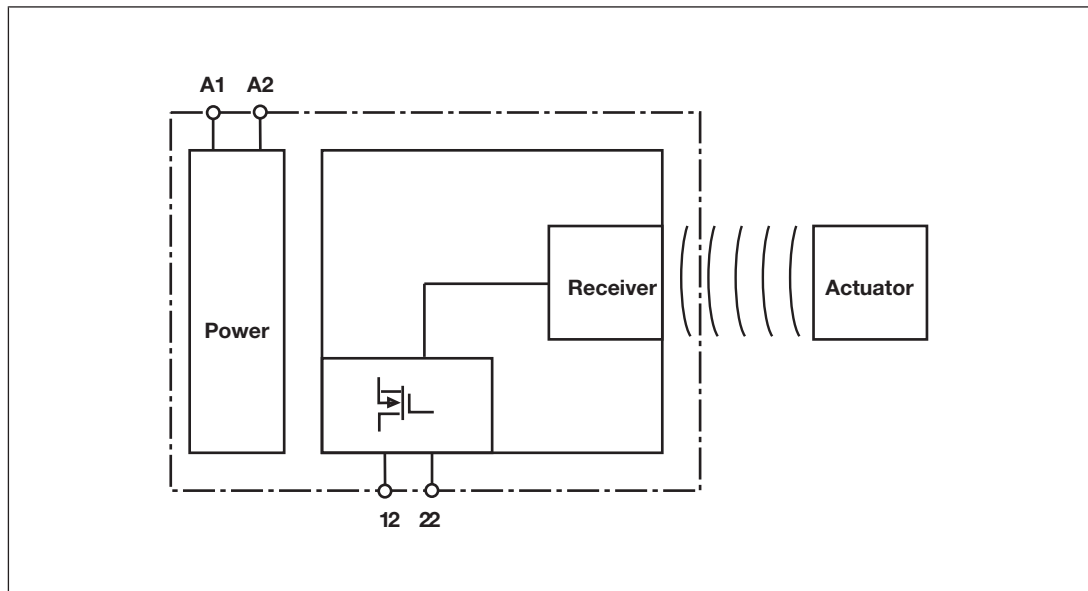

### Operating distances

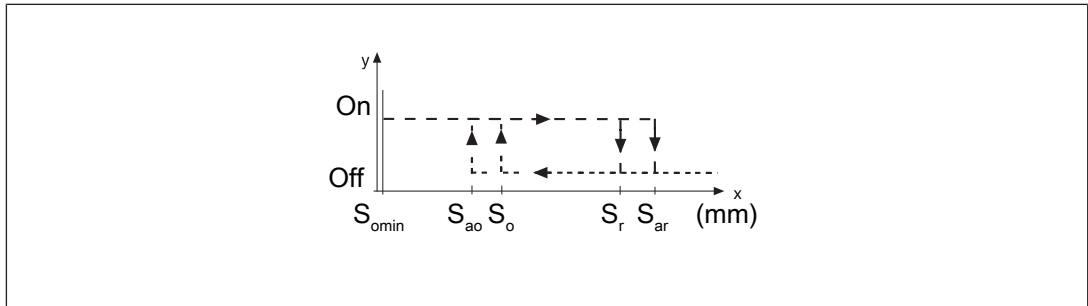

### Legend

- $S_{ao}$  Assured operating distance
- $S_{omin}$  Min. operating distance
- $S_{ar}$  Assured release distance

The offset-independent values for the switching distances are included in the [Technical details](#) [📖 26].

### Lateral and vertical offset

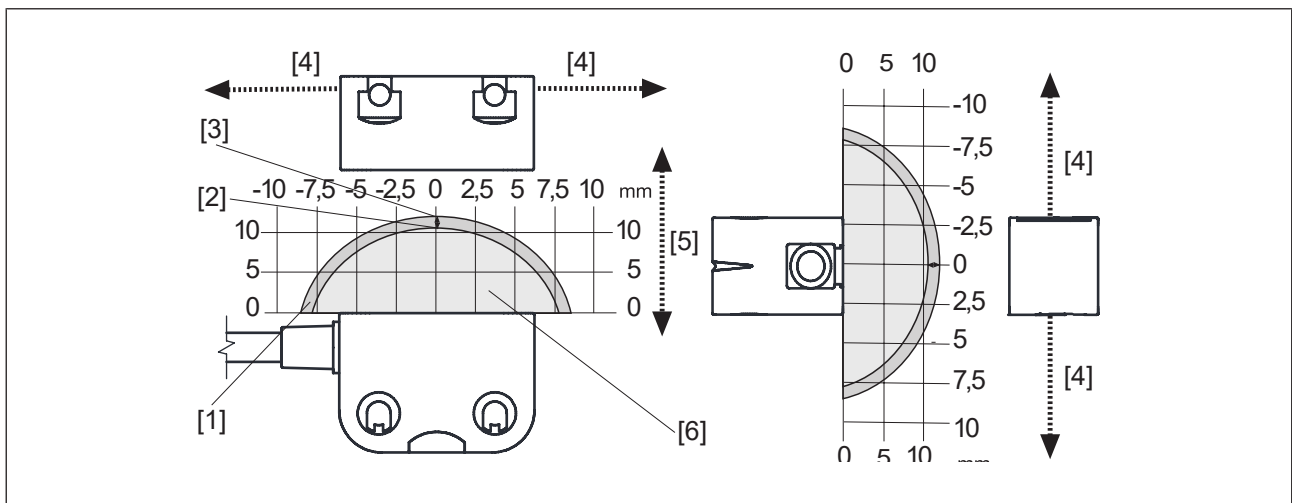

Fig.: Safety switches PSEN cs4.2n with actuator PSEN cs4.1

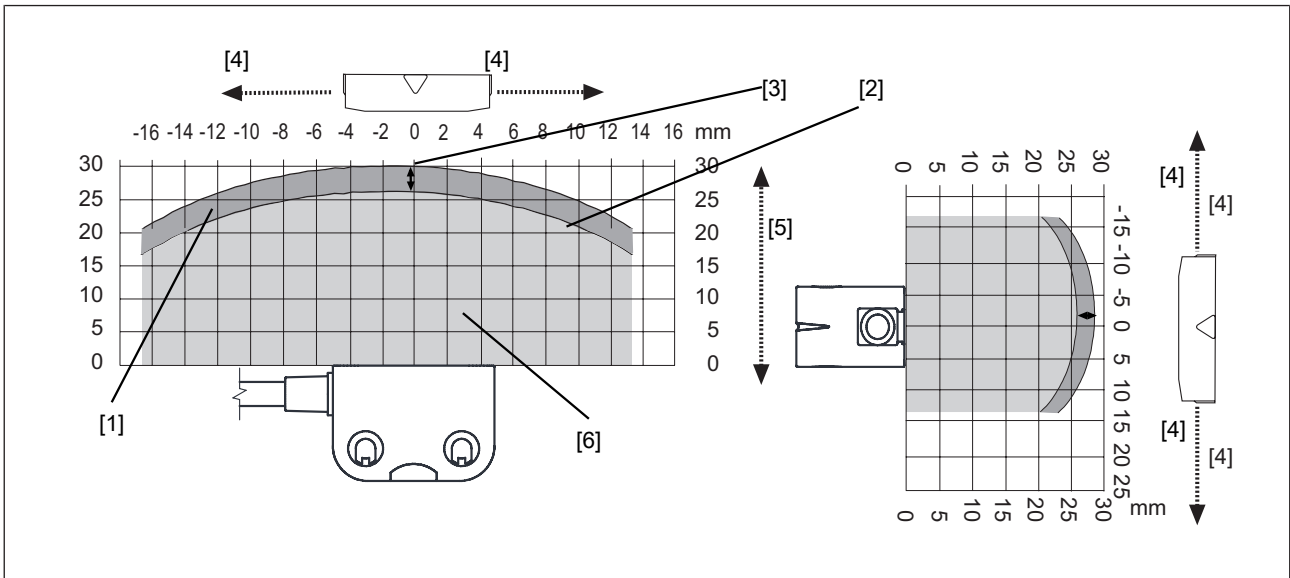

Fig.: Safety switches PSEN cs4.2n with actuator PSEN cs2.1

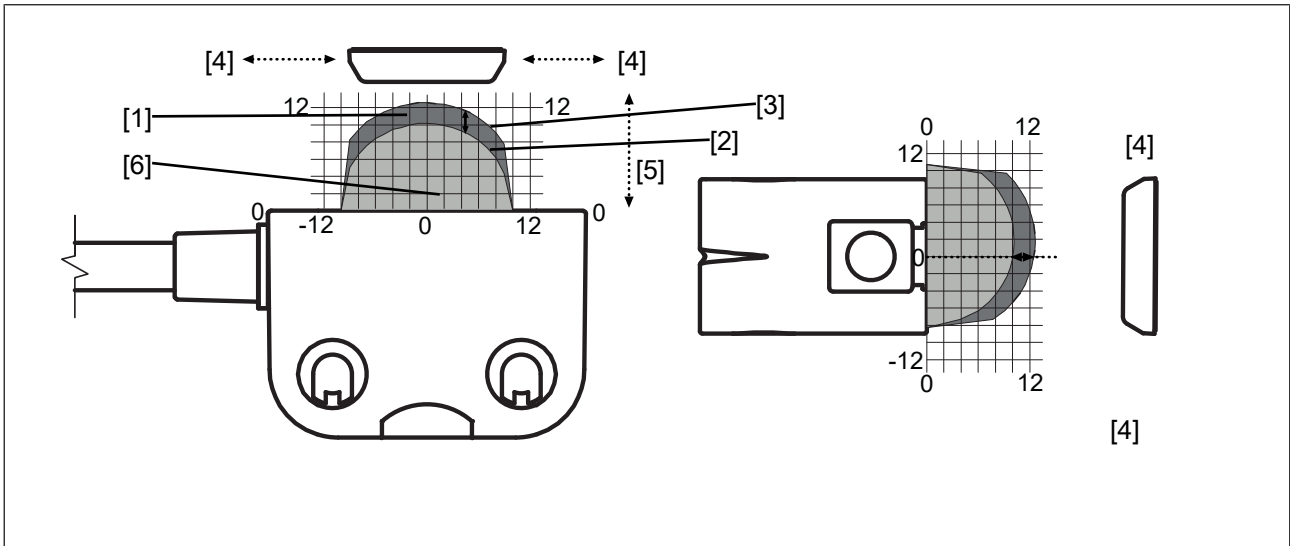

Fig.: Safety switches PSEN cs4.2n with actuator PSEN cs4.1 low profile glue or PSEN cs4.1 low profile screw

**Legend**

- [1] Hysteresis
- [2] Typical operating distance  $S_o$
- [3] Typical release distance  $S_r$
- [4] Offset in mm
- [5] Operating distance in mm
- [6] Response range

## Wiring

Please note:

- ▶ Information given in the "Technical details" must be followed.
- ▶ Switch off the supply voltage before disconnecting the plug-in connection.
- ▶ Make sure that when connecting or separating the connector the pollution degree 1 or 2 is maintained.
- ▶ The power supply must meet the regulations for extra low voltages with protective electrical separation (SELV, PELV).
- ▶ The outputs of the safety switch must have a protective separation to voltages over 60 V AC.
- ▶ The supply voltage to the safety switch must be protected with a 2 A to 4 A quick-acting fuse.
- ▶ Ensure the wiring and EMC requirements of EN 60204-1 are met.

### Pin assignment, connector and cable

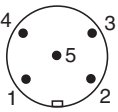
	5-pin M12 male connector
--	--------------------------

PIN	Pin designation	Function	Wire colour
1	A1	+24 UB	Brown
2	12	Output, channel1	White
3	A2	0 V UB	Blue
4	22	Output, channel2	Black
5	-	Do not connect	Grey

The wire colour also applies for the cable available from Pilz as an accessory.

## Connection to evaluation devices

Make sure that the selected evaluation device has the following property:

- ▶ OSSD signals are evaluated through 2 channels with plausibility monitoring

Please note:

- ▶ Information given in the [Technical details \[26\]](#) must be followed.

### Connection diagram, single connection

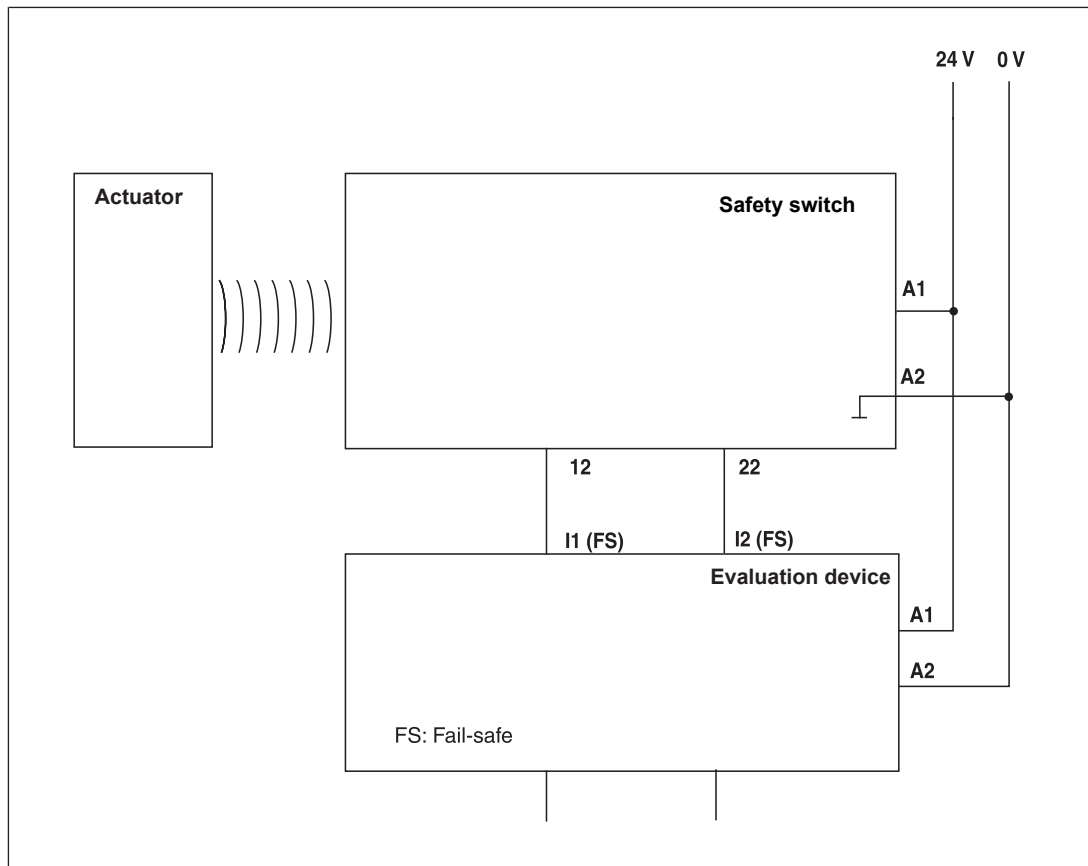

Suitable Pilz evaluation devices are, for example:

- ▶ PNOZelog for safety gate monitoring
- ▶ PNOZpower for safety gate monitoring
- ▶ PNOZsigma for safety gate monitoring
- ▶ PNOZ X for safety gate monitoring
- ▶ PNOZmulti for safety gate monitoring  
Configure the switch in the PNOZmulti Configurator with switch type 3.
- ▶ PSS for safety gate monitoring with standard function block SB064, SB066 or FS\_Safety Gate
- ▶ PSSuniversal PLC for safety gate monitoring with function block FS\_SafetyGate

The correct connection to the respective evaluation device is described in the operating manual for the evaluation device. Make sure that the connection is made in accordance with the specifications in the operating manual for the selected evaluation device.

The connections to two evaluation devices are shown on the following pages, by way of example:

- ▶ PNOZ s3 and
- ▶ PNOZmulti

**PNOZ s3**

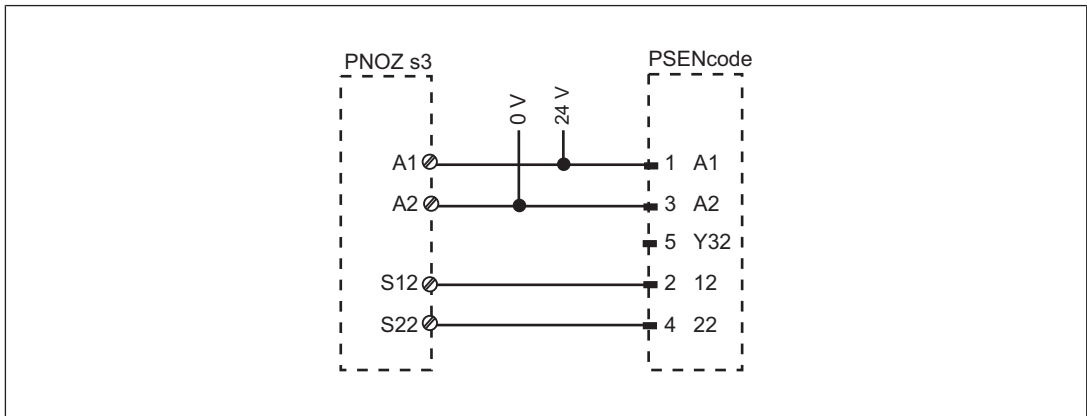

**PNOZmulti**

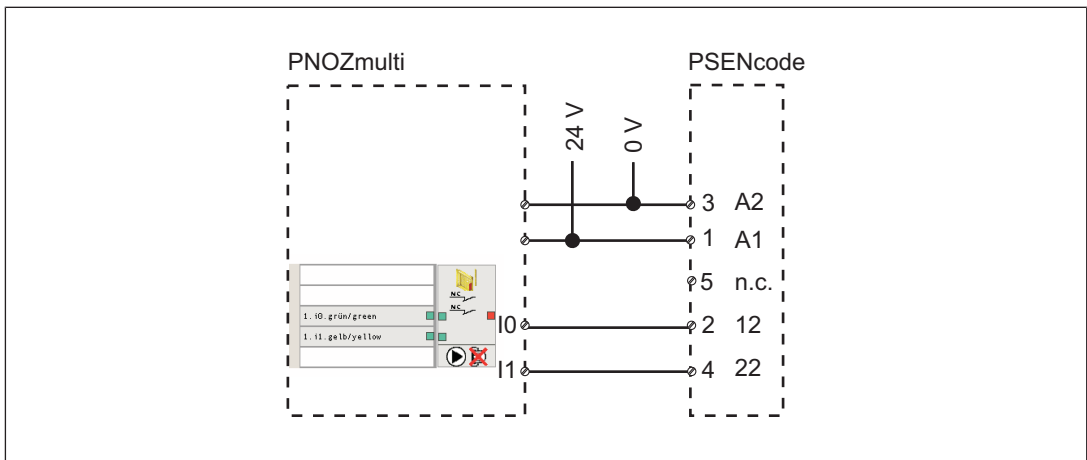

## Teaching in the actuator

The first actuator to be detected by the safety switch (see Intended use) is taught in automatically as soon as it is brought into the response range.



### NOTICE

No other actuator may be taught in once this actuator has been taught.

## Installation

### General







### CAUTION!

#### Potential loss of safety function due to changed device properties

The unit's properties may be affected if installed in an environment containing electrically or magnetically conductive material.

- Please check the operating distances and the assured release distance.

- ▶ The safety switch and actuator should be installed opposite each other in parallel.
- ▶ Torque setting: Please note the information provided under [Technical details](#)  26].
- ▶ The distance between two safety switches must be maintained (see [Technical details](#)  26]).
- ▶ Make sure that the safety switch and actuator cannot be used as an end stop.
- ▶ Please note the installation measures in accordance with EN ISO 14119 for a safety switch design 4 and with level of coding High.
- ▶ Please note the permitted bending radii for the cable (see [Technical details](#)  26]), to avoid excessive force on the individual strands.
- ▶ Make sure that the bend protection is not damaged. Such damage can cause the whole product to fail.
- ▶ For simpler installation, the mounting brackets (see [Order reference for Accessories](#)  34]) can be used.

### Safety switch

- ▶ Safety switches should only be secured using M4 screws with a flat head (e.g. M4 cheese-head or pan head screws).

### Procedure:

1. Provide the mounting surface with two drill holes for fastening the safety switch (see [Dimensions in mm](#)  23]).
2. Use two screws to fix the safety switch in place. Do not fully tighten the 2nd screw on the safety switch.

**Actuator cs2.1 or cs4.1**

**Procedure actuator PSEN cs4.1:**

1. Only use M4 screws with a flat head (e.g. M4 cheese-head or pan head screws).  
Provide the mounting surface with two drill holes for the screw connection of the actuator (see [Dimensions in mm](#) [📖 23]).
2. Attach the screws for the actuator, leaving a distance of 3 ... 6 mm between the screw head and plate.
3. Slide the actuator on to the screws. The arrows on the labelled surfaces of the safety switch and actuator must face each other. Align the actuator and tighten the screws.
4. The actuator should be protected from unauthorised removal and from contamination. Close the mounting holes using the seals provided. The use of seals should be regarded as equivalent to using permanent fastenings in accordance with EN ISO 14119.

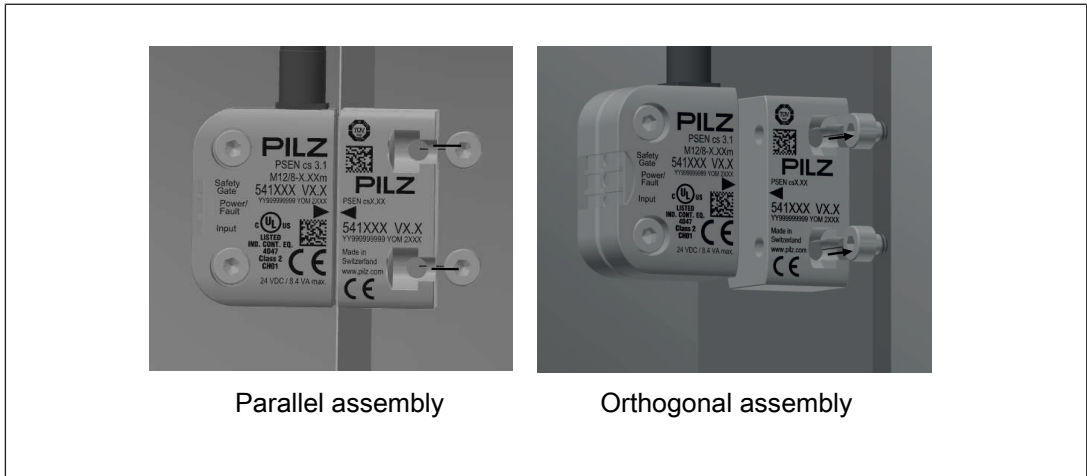

**Procedure actuator PSEN cs2.1:**

1. Use permanently secured M5 safety screws with a flat head (e.g. M5 cheese-head or pan head screws).

Provide the mounting surface with two drill holes for the screw connection of the actuator (see [Dimensions in mm](#) [ 23]).

2. Use two screws to fix the actuator in place. Align the actuator and tighten the screws.

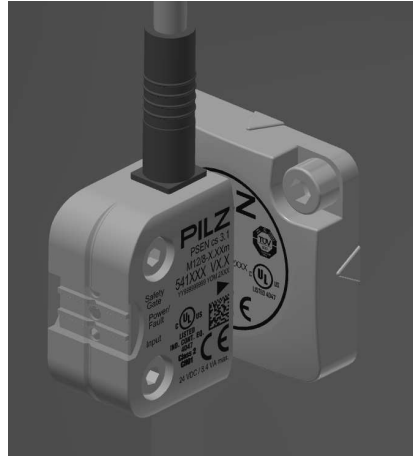
**Actuator cs3.1 low profile****WARNING!****Loss of the manipulation protection by inadequate environmental conditions**

The loss of the manipulation protection can allow manipulation of the interlocking device and it may lead to serious injury or death.

- Make sure that the actuator has no direct or repetitive contact with materials such as methyl ethyl ketone (MEK), petrol or isopropanol.

- ▶ The actuator is secured against unauthorised removal, and against contamination by the sealing. The seal should be regarded as equivalent to using permanent fastenings in accordance with EN ISO 14119.
- ▶ By removing the actuator, the actuator will be destroyed.
- ▶ The actuator's adhesive force on the materials aluminium, stainless steel, polycarbonate and glass was checked. For deviating surface materials check the adhesive force on the surface.
- ▶ After a cure time of 24 hours, 90 % of the final adhesive force are achieved. The hardening must take place at min. 20 °C. With lower temperatures the cure time is clearly extended.
- ▶ No continuous force must affect the actuator.

### Procedure actuator PSEN cs4.1 low profile glue

1. To seal the low profile actuators correctly, it is necessary to prepare the surface to which the actuator is to be attached.

The surface must be clean, dry and free of grease.

Wipe off any solved grease and contaminations with a new, dry paper cloth.

Clean the surface with 70% isopropanol. Use lint-free paper cloths and change the paper cloths frequently.

The adhesive surface is clean when the paper remains clean.

The cleaned surfaces must be sealed immediately to prevent any new contamination by dust and fingerprints.

2. Remove the protective foil from the assembly aid and fix it to the sensing area of the safety switch.
3. Place the actuator into the assembly aid so that the actuator's covered adhesive surface is on the surface.

Make sure that the actuator's centre is on the same level as the orientation arrows of the sensor and in the centre of the sensor.

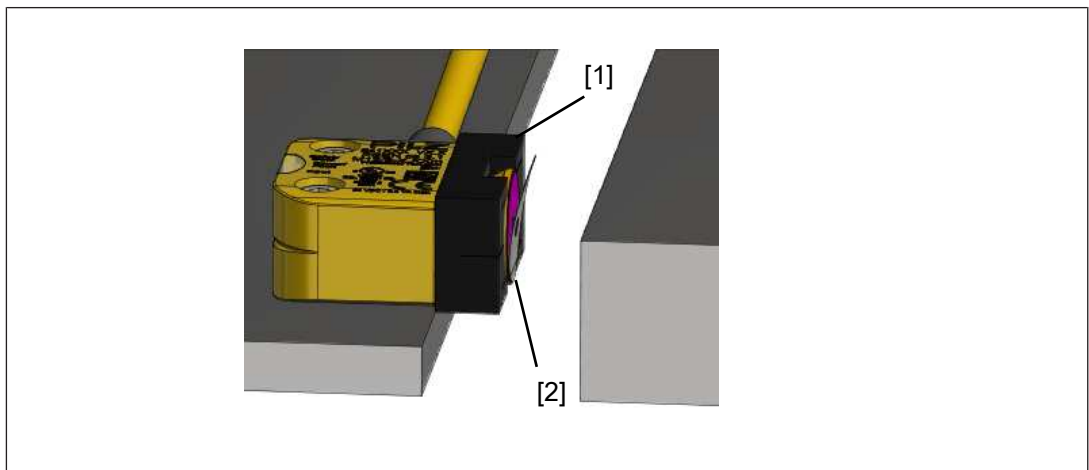

Fig.: Safety switch with assembly aid and low profile actuator

### Legend

[1] Assembly aid for low profile actuator

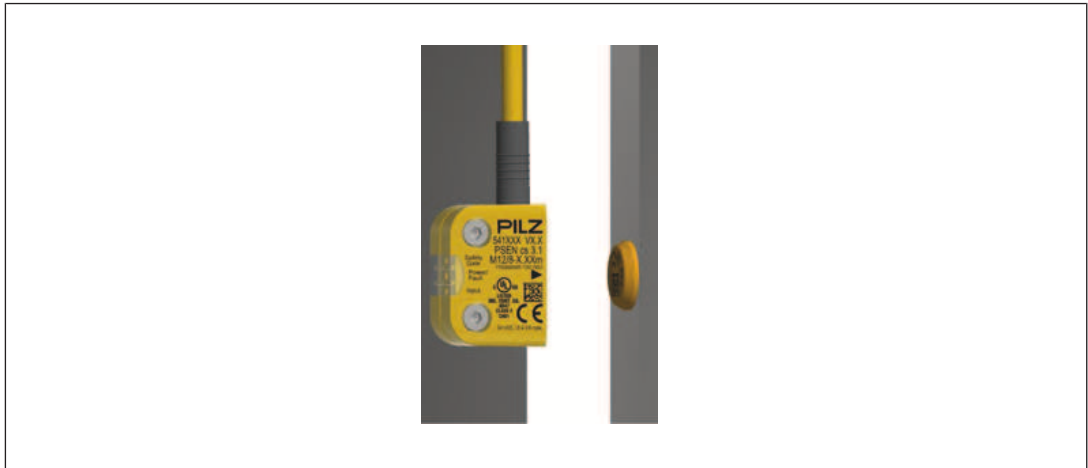

[2] low profile actuator

4. Remove the protective foil from the adhesive foil of the actuator.  
Do not touch the adhesive foil after removing the protective foil!
5. Close the safety gate carefully and then press the actuator to the adhesive position.
6. Press on the actuator for at least 3 seconds with approx. 50 N.  
After this time, an adhesive force of approx. 50 % is achieved. The full adhesive force is achieved after 72 hours at an ambient temperature of at least 20 °C.



7. Check the adhesive force of the glue after 10 minutes.  
The actuator must no move when pressed sideways.
8. Remove the assembly aid from the safety switch and clean the sensing area of the safety switch.

#### Procedure actuator PSEN cs4.1 low profile screw

1. Provide the mounting surface with a drill hole for an additional screw connection of the actuator (see [Dimensions in mm](#)  23]).
2. To seal the low profile actuators correctly, it is necessary to prepare the surface to which the actuator is to be attached.  
The surface must be clean, dry and free of grease.  
Wipe off any solved grease and contaminations with a new, dry paper cloth.  
Clean the surface with 70% isopropanol. Use lint-free paper cloths and change the paper cloths frequently.  
The adhesive surface is clean when the paper remains clean.  
The cleaned surfaces must be sealed immediately to prevent any new contamination by dust and fingerprints.
3. Remove the protective foil from the assembly aid and fix it to the sensing area of the safety switch.
4. Place the actuator into the assembly aid so that the actuator's covered adhesive surface is on the surface.  
Make sure that the actuator's centre is on the same level as the orientation arrows of the sensor and in the centre of the sensor.
5. Remove the protective foil from the adhesive foil of the actuator.  
Do not touch the adhesive foil after removing the protective foil!
6. Insert the screw into the actuator's hole and position the screw at the hole on the mounting surface.  
To screw on the actuator, use the supplied plastic M3 countersunk screw.  
When using a screw mad from metal the operating distance change, please note the [Warning](#)  15].

7. Press on the actuator for at least 3 seconds with approx. 50 N.

After this time, an adhesive force of approx. 50 % is achieved. The full adhesive force is achieved after 72 hours at an ambient temperature of at least 20 °C.

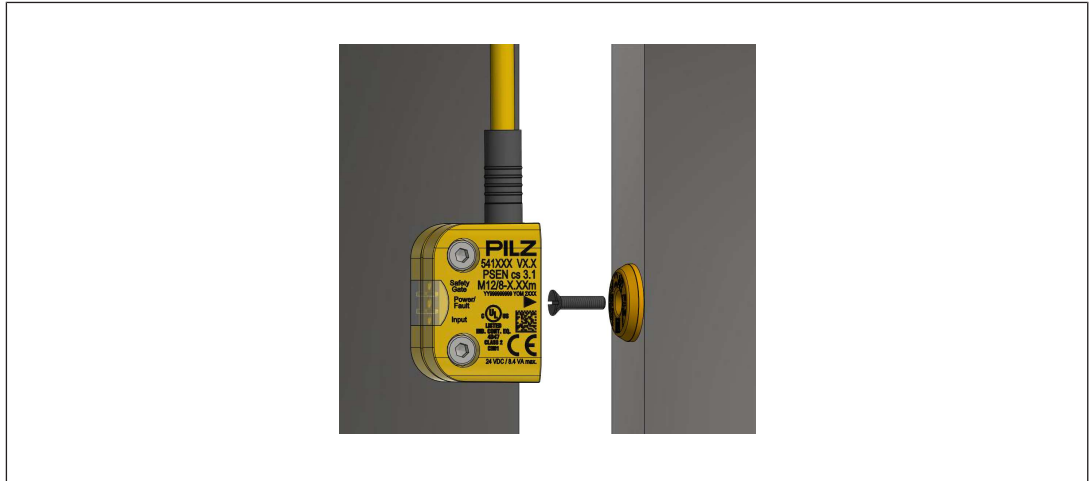

8. Check the adhesive force of the glue after 10 minutes.  
The actuator must no move when pressed sideways.
9. Tighten the M3 plastic screw to 0,8 Nm.

### Align safety switch and actuator

#### Procedure:

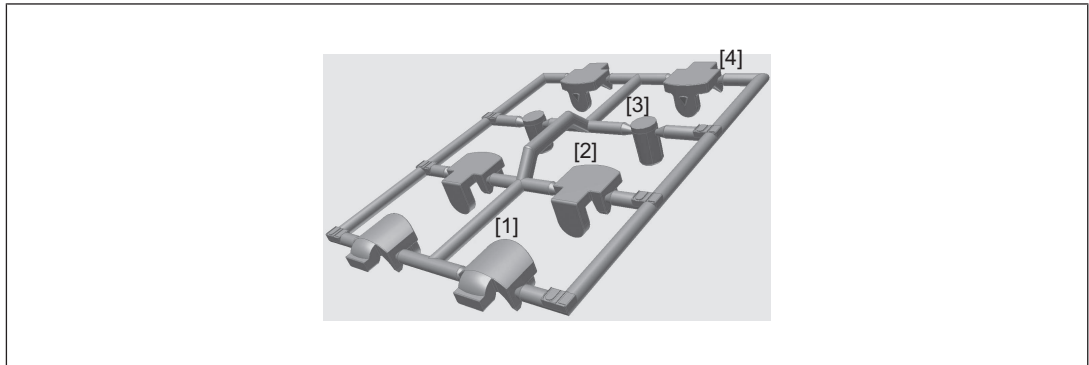

1. Align the safety switch and tighten the screws.
2. Actuator PSEN cs4.1  
Align the actuator and tighten the screws.
3. Close the mounting holes using the seals provided (see diagram).  
Use the seals [1] for UL approval or [4] without UL approval.



#### Legend

- [1] Side seal with UL approval
  - [2] Bottom seal
  - [3] Top seal, sensing side
  - [4] Side seal without UL approval
4. Use the seals to close the mounting holes on the sensing face of the safety switch (see diagram, [3]).
  5. If necessary, use the seals to close the unused mounting holes on the actuator (see diagram, [2]).

### Adjustment

- ▶ The stated operating distances (see [Technical details](#)  26) only apply when the safety switch and actuator are installed facing each other in parallel. Operating distances may deviate if other arrangements are used.
- ▶ Note the maximum permitted lateral and vertical offset (see [Operating distances](#)  10) and [Lateral and vertical offset](#)  10).

## Operation



### NOTICE

The safety function should be checked after initial commissioning and each time the plant/machine is changed. The safety functions may only be checked by qualified personnel.

### Status indicators:

- ▶ "Power/Fault" LED lights up green: The unit is ready for operation
- ▶ "Safety Gate" LED lights up yellow: Actuator is within the response range
- ▶ "Input" LED lights up yellow: There is a high signal at both inputs

### Fault indicator:

- ▶ "Input" LED lights up yellow: the signal switches from high to low at one input, while a high signal remains on the other input (partial operation).  
Remedy: Open both channels of the input circuit.
- ▶ "Power/Fault" LED lights up red: Error message  
Remedy: Rectify fault and interrupt power supply.

## Dimensions in mm

### Safety switch

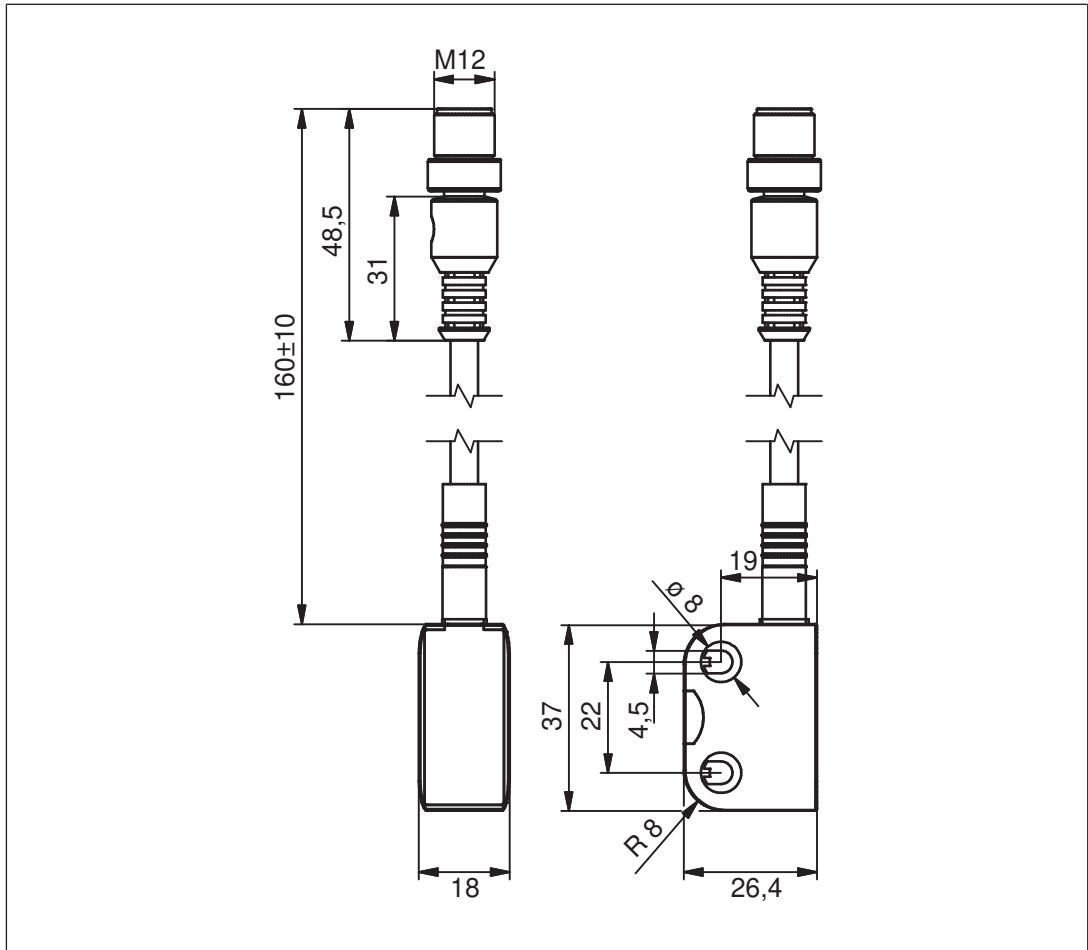

**Actuator**

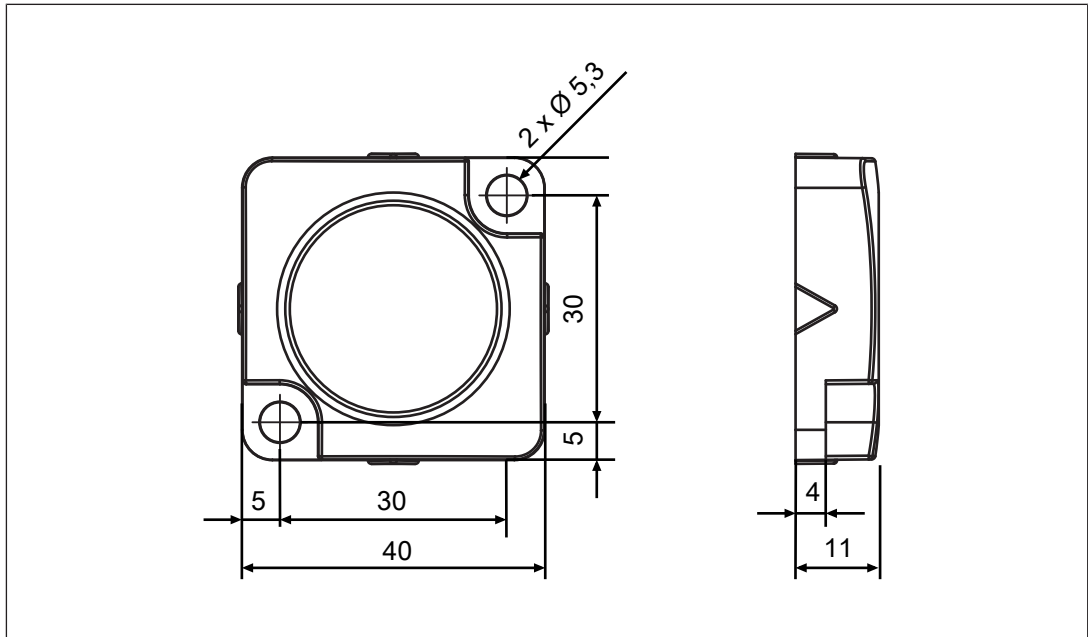

Fig.: Actuator PSEN cs2.1

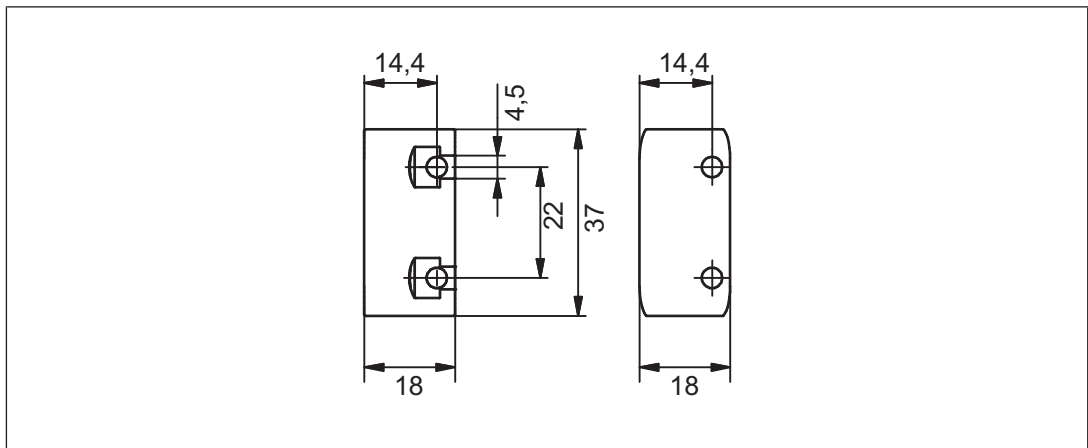
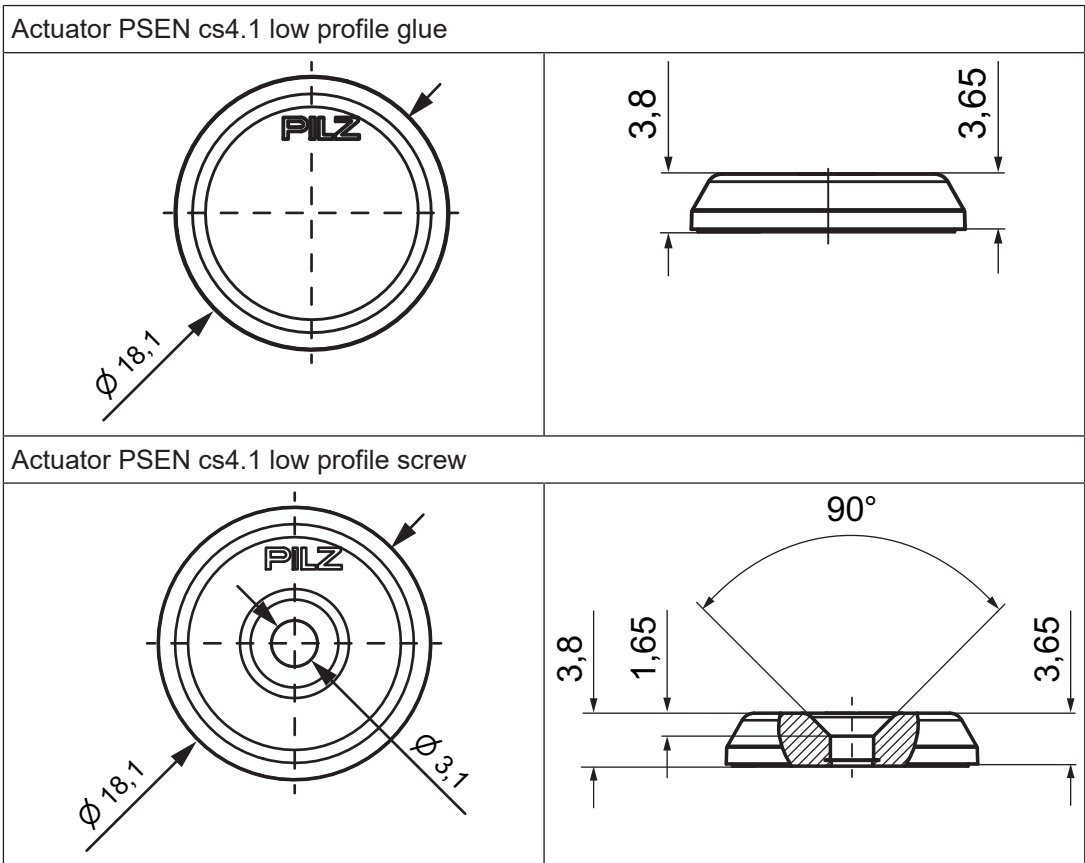

Fig.: Actuator PSEN cs4.1



## Technical details safety switch

<b>General</b>	
Certifications	<b>CE, EAC (Eurasian), FCC, IC, TÜV, cULus Listed</b>
Sensor's mode of operation	<b>Transponder</b>
Coding level in accordance with EN ISO 14119	<b>High</b>
Design in accordance with EN ISO 14119	<b>4</b>
Classification in accordance with EN 60947-5-3	<b>PDDB</b>
Pilz coding type	<b>uniquely coded</b>
<b>Transponder</b>	
Frequency band	<b>122 kHz - 128 kHz</b>
Max. transmitter output	<b>15 mW</b>
<b>Electrical data</b>	
Supply voltage	
Voltage	<b>24 V</b>
Kind	<b>DC</b>
Voltage tolerance	<b>-20 %/+20 %</b>
Output of external power supply (DC)	<b>1 W</b>
Max. switching frequency	<b>3 Hz</b>
Max. cable capacitance at the safety outputs	
No-load, PNOZ with relay contacts	<b>400 nF</b>
PNOZmulti, PNOZelog, PSS	<b>400 nF</b>
Max. inrush current impulse	
Current pulse, A1	<b>0,58 A</b>
Pulse duration, A1	<b>1 ms</b>
No-load current	<b>20 mA</b>
<b>Semiconductor outputs</b>	
OSSD safety outputs	<b>2</b>
Switching current per output	<b>100 mA</b>
Breaking capacity per output	<b>2,4 W</b>
Potential isolation from system voltage	<b>No</b>
Short circuit-proof	<b>yes</b>
Residual current at outputs	<b>20 µA</b>
Voltage drop at OSSDs	<b>3,5 V</b>
Lowest operating current	<b>0 mA</b>
Utilisation category in accordance with EN 60947-1	<b>DC-12</b>
<b>Times</b>	
Test pulse duration, safety outputs	<b>450 µs</b>
Switch-on delay	
after UB is applied	<b>1 s</b>
Actuator typ.	<b>60 ms</b>
Actuator max.	<b>150 ms</b>
Delay-on de-energisation	
Actuator typ.	<b>40 ms</b>
Actuator max.	<b>260 ms</b>

<b>Times</b>	
Risk time in accordance with EN 60947-5-3	<b>260 ms</b>
Supply interruption before de-energisation	<b>10 ms</b>
Simultaneity, channel 1 and 2 max.	$\infty$
<b>Environmental data</b>	
Ambient temperature	
In accordance with the standard	<b>EN 60068-2-14</b>
Temperature range	<b>-25 - 70 °C</b>
Storage temperature	
In accordance with the standard	<b>EN 60068-2-1/-2</b>
Temperature range	<b>-25 - 70 °C</b>
Climatic suitability	
In accordance with the standard	<b>EN 60068-2-78</b>
Humidity	<b>93 % r. h. at 40 °C</b>
EMC	<b>EN 60947-5-3</b>
Vibration	
In accordance with the standard	<b>EN 60947-5-2</b>
Frequency	<b>10 - 55 Hz</b>
Amplitude	<b>1 mm</b>
Shock stress	
In accordance with the standard	<b>EN 60947-5-2</b>
Acceleration	<b>30g</b>
Duration	<b>18 ms</b>
Airgap creepage	
Overvoltage category	<b>III</b>
Pollution degree	<b>3</b>
Rated insulation voltage	<b>75 V</b>
Rated impulse withstand voltage	<b>0,8 kV</b>
Protection type	
Housing	<b>IP6K9K</b>
Connector	<b>IP67</b>
<b>Operating distances</b>	
Actuator 1	
Type	<b>PSEN cs4.1</b>
Assured operating distance Sao	<b>8 mm</b>
Typical operating distance So	<b>11 mm</b>
Assured release distance Sar	<b>20 mm</b>
Typical release distance Sr	<b>14 mm</b>
Repetition accuracy switching distances	<b>10 %</b>
Change of operating distance with temperature changes	<b>+0,01mm/°C</b>
Typ. Hysteresis	<b>2 mm</b>

## Operating distances

### Actuator 2

Type	<b>PSEN cs2.1</b>
Assured operating distance $S_{ao}$	<b>10 mm</b>
Typical operating distance $S_o$	<b>25 mm</b>
Assured release distance $S_{ar}$	<b>33 mm</b>
Typical release distance $S_r$	<b>29 mm</b>
Repetition accuracy switching distances	<b>10 %</b>
Change of operating distance with temperature changes	<b>+0,1mm/°C</b>
Typ. Hysteresis	<b>3 mm</b>

### Actuator 3

Type	<b>PSEN cs4.1 low profile glue</b>
Assured operating distance $S_{ao}$	<b>5 mm</b>
Typical operating distance $S_o$	<b>10 mm</b>
Assured release distance $S_{ar}$	<b>20 mm</b>
Typical release distance $S_r$	<b>12 mm</b>
Repetition accuracy switching distances	<b>10 %</b>
Change of operating distance with temperature changes	<b>+0,01mm/°C</b>
Typ. Hysteresis	<b>2 mm</b>

### Actuator 4

Typ	<b>PSEN cs4.1 low profile screw</b>
Assured operating distance $S_{ao}$	<b>5 mm</b>
Typical operating distance $S_o$	<b>10 mm</b>
Assured release distance $S_{ar}$	<b>20 mm</b>
Typical release distance $S_r$	<b>12 mm</b>
Repetition accuracy switching distances	<b>10 %</b>
Change of operating distance with temperature changes	<b>+0,01mm/°C</b>
Typical hysteresis	<b>2 mm</b>

## Mechanical data

Min. bending radius (fixed permanently) K1	<b>5 x Ø</b>
Min. bending radius (moving) K1	<b>10 x Ø</b>
Cable diameter K1	<b>5,55 mm</b>
Min. distance between safety switches	<b>100 mm</b>
Sensor flush installation in accordance with EN 60947-5-2	<b>Yes, follow installation guidelines</b>
Connection type	<b>M12, 5-pin male connector</b>
Cable	<b>Li9Y11Y 8 x 0,14 mm<sup>2</sup></b>
Material	
Top	<b>PBT</b>
Max. torque setting for fixing screws	<b>0,8 Nm</b>
Dimensions	
Height	<b>37 mm</b>
Width	<b>26 mm</b>
Depth	<b>18 mm</b>

**Mechanical data**

Weight of safety switch	<b>40 g</b>
-------------------------	-------------

Where standards are undated, the 2016-10 latest editions shall apply.

**Technical details actuator**

**Order no. 540180 - 541180**

See below for more order numbers

<b>General</b>	<b>540180</b>	<b>541180</b>
Certifications	<b>CE, TÜV, cULus Listed</b>	<b>CE, EAC (Eurasian), TÜV, cULus Listed</b>
Sensor's mode of operation	<b>Transponder</b>	<b>Transponder</b>
Coding level in accordance with EN ISO 14119	<b>High</b>	<b>High</b>
Pilz coding type	<b>fully coded</b>	<b>fully coded</b>
<b>Transponder</b>	<b>540180</b>	<b>541180</b>
Frequency band	<b>122 kHz - 128 kHz</b>	<b>122 kHz - 128 kHz</b>
<b>Environmental data</b>	<b>540180</b>	<b>541180</b>
Ambient temperature		
In accordance with the standard	<b>EN 60068-2-14</b>	<b>EN 60068-2-14</b>
Temperature range	<b>-25 - 70 °C</b>	<b>-25 - 70 °C</b>
Storage temperature		
In accordance with the standard	<b>EN 60068-2-1/-2</b>	<b>EN 60068-2-1/-2</b>
Temperature range	<b>-40 - 85 °C</b>	<b>-25 - 70 °C</b>
Climatic suitability		
In accordance with the standard	<b>EN 60068-2-78</b>	<b>EN 60068-2-78</b>
Humidity	<b>93 % r. h. at 40 °C</b>	<b>93 % r. h. at 40 °C</b>
EMC	<b>EN 60947-5-3</b>	<b>EN 60947-5-3</b>
Vibration		
In accordance with the standard	<b>EN 60947-5-2</b>	<b>EN 60947-5-2</b>
Frequency	<b>10 - 55 Hz</b>	<b>10 - 55 Hz</b>
Amplitude	<b>1 mm</b>	<b>1 mm</b>
Shock stress		
In accordance with the standard	<b>EN 60947-5-2</b>	<b>EN 60947-5-2</b>
Acceleration	<b>30g</b>	<b>30g</b>
Duration	<b>11 ms</b>	<b>18 ms</b>
Protection type		
Housing	<b>IP6K9K</b>	<b>IP6K9K</b>
<b>Mechanical data</b>	<b>540180</b>	<b>541180</b>
Material	<b>–</b>	<b>PBT</b>
Material		
Top	<b>PBT</b>	<b>–</b>
Max. torque setting for fixing screws	<b>1 Nm</b>	<b>0,8 Nm</b>

<b>Mechanical data</b>	<b>540180</b>	<b>541180</b>
Dimensions		
Height	11 mm	37 mm
Width	40 mm	18 mm
Depth	40 mm	18 mm
Weight	20 g	11 g

**Order no. 541187 - 541188**

<b>General</b>	<b>541187</b>	<b>541188</b>
Certifications	CE, EAC (Eurasian), TÜV, cULus Listed	CE, EAC (Eurasian), TÜV, cULus Listed
Sensor's mode of operation	Transponder	Transponder
Coding level in accordance with EN ISO 14119	High	High
Pilz coding type	fully coded	fully coded

<b>Transponder</b>	<b>541187</b>	<b>541188</b>
Frequency band	122 kHz - 128 kHz	122 kHz - 128 kHz

<b>Environmental data</b>	<b>541187</b>	<b>541188</b>
---------------------------	---------------	---------------

Ambient temperature		
In accordance with the standard	EN 60068-2-14	EN 60068-2-14
Temperature range	-25 - 70 °C	-25 - 70 °C
Max. at max. operating height	+60 °C	+60 °C
Max. at max. operating height <2000 m	+70 °C	+70 °C

Storage temperature		
In accordance with the standard	EN 60068-2-1/-2	EN 60068-2-1/-2
Temperature range	-40 - 85 °C	-40 - 85 °C

Climatic suitability		
In accordance with the standard	EN 60068-2-30	EN 60068-2-30
Humidity	93 % r. h. at 40 °C	93 % r. h. at 40 °C

Max. operating height above sea level	4000 m	4000 m
---------------------------------------	--------	--------

EMC	EN 60947-5-3	EN 60947-5-3
-----	--------------	--------------

Vibration		
In accordance with the standard	EN 60947-5-2	EN 60947-5-2
Frequency	10 - 55 Hz	10 - 55 Hz
Amplitude	1 mm	1 mm

Shock stress		
In accordance with the standard	EN 60947-5-2	EN 60947-5-2
Acceleration	30g	30g
Duration	11 ms	11 ms

Protection type		
Housing	IP67	IP67

<b>Mechanical data</b>	<b>541187</b>	<b>541188</b>
------------------------	---------------	---------------

Material		
Top	PBT	PBT

<b>Mechanical data</b>	<b>541187</b>	<b>541188</b>
Max. torque setting for fixing screws	–	<b>0,1 Nm</b>
Dimensions		
Height	<b>3,8 mm</b>	<b>3,8 mm</b>
Width	<b>18 mm</b>	<b>18 mm</b>
Depth	<b>18 mm</b>	<b>18 mm</b>
Weight	<b>2 g</b>	<b>2 g</b>

Where standards are undated, the 2016-10 latest editions shall apply.

### **Classification according to ZVEI, CB24I**

The following tables describe the classes and specific values of the product interface and the classes of interfaces compatible with it. The classification is described in the ZVEI position paper "Classification of Binary 24 V Interfaces - Functional Safety aspects covered by dynamic testing".

<b>Single-pole output</b>	
<b>Interfaces</b>	
Source	
Interface	Sensor
Class	C2
Drain	
Class	C1, C2
<b>Source parameters</b>	
Max. test pulse duration	450 $\mu$ s
Max. rated current	0,1 A
Max. capacitive load	0,4 $\mu$ F

## Safety characteristic data



### NOTICE

You must comply with the safety characteristic data in order to achieve the required safety level for your plant/machine.

Operating mode	EN ISO 13849-1: 2015 PL	EN ISO 13849-1: 2015 Category	EN 62061 SIL CL	EN 62061 PFH <sub>D</sub> [1/h]	IEC 61511 SIL	IEC 61511 PFD	EN ISO 13849-1: 2015 T <sub>M</sub> [year]
2-ch. OSSD	PL e	Cat. 4	SIL CL 3	2,62E-09	–	7,68E-05	20

Explanatory notes for the safety-related characteristic data:

- ▶ The SIL CL value in accordance with EN 62061 corresponds to the SIL value in accordance with EN 61508.
- ▶ T<sub>M</sub> is the maximum mission time in accordance with EN ISO 13849-1. The value also applies as the retest interval in accordance with EN 61508-6 and IEC 61511 and as the proof test interval and mission time in accordance with EN 62061.

All the units used within a safety function must be considered when calculating the safety characteristic data.



### INFORMATION

A safety function's SIL/PL values are **not** identical to the SIL/PL values of the units that are used and may be different. We recommend that you use the PASCAL software tool to calculate the safety function's SIL/PL values.

## Supplementary data

### Radio approval

USA/Canada

**FCC** ID: VT8-PSENCSS3  
**IC:** 7482A-PSENCSS3

FCC/IC-Requirements:

This product complies with Part 15 of the FCC Rules and with Industry Canada licence-exempt RSS standards.

Operation is subject to the following two conditions:

- 1) this product may not cause harmful interference, and
- 2) this product must accept any interference received, including interference that may cause undesired operation.

Changes or modifications made to this product not expressly approved by Pilz may void the FCC authorization to operate this equipment.

NOTE: This equipment has been tested and found to comply with the limits for a Class A digital device, pursuant to Part 15 of the FCC Rules. These limits are designed to provide reasonable protection against harmful interference when the equipment is operated in a commercial environment. This equipment generates, uses, and can radiate radio frequency energy and, if not installed and used in accordance with the instruction manual, may cause harmful interference to radio communications. Operation of this equipment in a residential area is likely to cause harmful interference in which case the user will be required to correct the interference at his own expense.

Le présent produit est conforme aux CNR d'Industrie Canada applicables aux appareils radio exempts de licence. L'exploitation est autorisée aux deux conditions suivantes:

- (1) le produit ne doit pas produire de brouillage, et
- (2) l'utilisateur de le produit doit accepter tout brouillage radioélectrique subi, même si le brouillage est susceptible d'en compromettre le fonctionnement.

### Order reference

#### Safety switch

Product type	Features		Order no.
PSEN cs4.2n 1switch	Safety switch, uniquely fully coded	5-pin M12 connector	541 253

#### Actuator

Product type	Features		Order no.
PSEN cs2.1 1 actuator	Actuator, fully coded		540 180
PSEN cs4.1 1 actuator	Actuator, fully coded		541 180
PSEN cs4.1 low profile glue 1 actuator	Actuator fully coded, without screw		541 187
PSEN cs4.1 low profile screw 1 actuator	Actuator fully coded, with screw		541 188

#### Complete systems

Product type	Features		Order no.
PSEN cs4.2n /PSEN cs4.1 1 Unit	Safety gate system, uniquely fully coded	5-pin M12 connector	541 203

## Accessories

### Installation materials

Product type	Features	Order no.
PSEN bracket	Mounting bracket	532 110
PSEN mag/cs bracket straight	Mounting aid	532 111
PSEN screw M4x20 10pcs	Safety screws made from stainless steel with one-way slot	540 313
PSEN screw M4x26 10pcs	Safety screws made from stainless steel with one-way slot	540 314
PSEN screw M5x10 10pcs	Safety screws made from stainless steel with one-way slot	540 311
PSEN screw M5x20 10pcs	Safety screws made from stainless steel with one-way slot	540 312
PSEN cs1/2 bracket cable fix	Mechanical protection against defeat, protecting against unauthorised cable disconnection or damage for safety switches PSENcode cs1/2, PSENcode cs5/6 M12, PSENslock	532 112

### Cable

Product type	Connection 1	Connection 2	Length	Order No.
PSS67/PDP67 cable M12-5sf	Straight, M12, 5-pin, socket	Straight, M12, 5-pin, connector	3 m	380 208
			5 m	380 209
			10 m	380 210
			20 m	380 220
			30 m	380 211
PSS67/PDP67 cable M12-5af	Angled, M12, 5-pin, socket	Angled, M12, 5-pin, connector	3 m	380 212
			5 m	380 213
			10 m	380 214
			30 m	380 215
PSEN cable M12-5sf	Straight, M12, 5-pin, socket	Open cable	3 m	630 310
			5 m	630 311
			10 m	630 312
			20 m	630 298
			30 m	630 297
PSEN cable M12-5af	Angled, M12, 5-pin, socket	Open cable	3 m	630 347
			5 m	630 348
			10 m	630 349
			30 m	630 350
PDP67 F 8DI ION	Decentralised input module IP67 for PNOZmulti			773 600

### **EC declaration of conformity**

This product/these products meet the requirements of the following directives of the European Parliament and of the Council.

- ▶ 2006/42/EC on machines
- ▶ 2014/53/EC on radio equipment

The complete EC Declaration of Conformity is available on the Internet at [www.pilz.com/downloads](http://www.pilz.com/downloads).

Representative: Norbert Fröhlich, Pilz GmbH & Co. KG, Felix-Wankel-Str. 2, 73760 Ostfildern, Germany

# ▶ Support

Technical support is available from Pilz round the clock.

## Americas

**Brazil**  
+55 11 97569-2804

**Canada**  
+1 888 315 7459

**Mexico**  
+52 55 5572 1300

**USA (toll-free)**  
+1 877-PILZUSA (745-9872)

## Asia

**China**  
+86 21 60880878-216

**Japan**  
+81 45 471-2281

**South Korea**  
+82 31 778 3300

## Australia

+61 3 95600621

## Europe

**Austria**  
+43 1 7986263-0

**Belgium, Luxembourg**  
+32 9 3217570

**France**  
+33 3 88104003

**Germany**  
+49 711 3409-444

**Ireland**  
+353 21 4804983

**Italy, Malta**  
+39 0362 1826711

## Scandinavia

+45 74436332

## Spain

+34 938497433

## Switzerland

+41 62 88979-32

## The Netherlands

+31 347 320477

## Turkey

+90 216 5775552

## United Kingdom

+44 1536 462203

## You can reach our international hotline on:

+49 711 3409-444  
support@pilz.com

Pilz develops environmentally-friendly products using ecological materials and energy-saving technologies. Offices and production facilities are ecologically designed, environmentally-aware and energy-saving. So Pilz offers sustainability, plus the security of using energy-efficient products and environmentally-friendly solutions.



We are represented internationally. Please refer to our homepage [www.pilz.com](http://www.pilz.com) for further details or contact our headquarters.

Headquarters: Pilz GmbH & Co. KG, Felix-Wankel-Straße 2, 73760 Ostfildern, Germany  
Telephone: +49 711 3409-0, Telefax: +49 711 3409-133, E-Mail: [info@pilz.com](mailto:info@pilz.com), Internet: [www.pilz.com](http://www.pilz.com)



22181-EN-06, 2020-03 Printed in Germany  
 © Pilz GmbH & Co. KG, 2019  
 CECE®, CHRE®, CMSE®, InduraNET p®, Leansafe®, Master of Safety®, Master of Security®, PAS4000®, PAScale®, PASconfig®, Pilz®, PTT®, PLID®, PMCPirimo®, PMCPiritego®, PMCTendo®, PMD®, PMJ®, PNOZ®, PRBT®, PRCM®, PRCM®, PSEN®, PSS®, PVIS®, SafetyBUS p®, SafetyEYE®, SafetyNET p®, THE SPIRIT OF SAFETY® are registered and protected trademarks of Pilz GmbH & Co. KG in some countries. We would point out that product features may vary from the details stated in this document, depending on the status at the time of publication and the scope of the equipment. We accept no responsibility for the validity, accuracy and entirety of the text and graphics presented in this information. Please contact our Technical Support if you have any questions.