



PSEN cs5.1n

PILZ
THE SPIRIT OF SAFETY

- ▶ PSEN sensor technology

This document is the original document.

All rights to this documentation are reserved by Pilz GmbH & Co. KG. Copies may be made for the user's internal purposes. Suggestions and comments for improving this documentation will be gratefully received.

Source code from third-party manufacturers or open source software has been used for some components. The relevant licence information is available on the Internet on the Pilz homepage.

Pilz®, PIT®, PMI®, PNOZ®, Primo®, PSEN®, PSS®, PVIS®, SafetyBUS p®, SafetyEYE®, SafetyNET p®, the spirit of safety® are registered and protected trademarks of Pilz GmbH & Co. KG in some countries.



SD means Secure Digital

Introduction	5
Validity of documentation	5
Using the documentation	5
Definition of symbols	5
Safety	6
Intended use	6
Safety regulations	7
Safety assessment	7
Use of qualified personnel	7
Warranty and liability	7
Disposal	7
For your safety	8
Unit features	8
Function description	9
Basic function	9
Block diagram	9
Operating distances	10
Lateral and vertical offset	12
Wiring	18
Important information	18
Pin assignment, connector and cable	18
Connection to evaluation devices	18
Single connection	19
Connection to Pilz evaluation devices	19
Teaching in the actuator	20
Installation	21
General	21
Safety switch	23
Actuator 5.1	23
Actuator 5.1 low profile	23
Align safety switch and actuator	26
Use in operating heights higher than 2000 m above sea level	27
Adjustment	27
Operation	28
Normal mode	28
Error display	28

Dimensions in mm	29
Technical details safety switch	30
Technical details actuator	34
Classification according to ZVEI, CB24I	37
Safety characteristic data	37
Supplementary data	38
Radio approval.....	38
Order reference	38
Safety switch.....	38
Actuator	38
Complete systems	39
Accessories	39
EC declaration of conformity	40

Introduction

Validity of documentation

This documentation is valid for the product PSEN cs5.1n. It is valid until new documentation is published.

This operating manual explains the function and operation, describes the installation and provides guidelines on how to connect the product.

Using the documentation

This document is intended for instruction. Only install and commission the product if you have read and understood this document. The document should be retained for future reference.

Definition of symbols

Information that is particularly important is identified as follows:



DANGER!

This warning must be heeded! It warns of a hazardous situation that poses an immediate threat of serious injury and death and indicates preventive measures that can be taken.



WARNING!

This warning must be heeded! It warns of a hazardous situation that could lead to serious injury and death and indicates preventive measures that can be taken.



CAUTION!

This refers to a hazard that can lead to a less serious or minor injury plus material damage, and also provides information on preventive measures that can be taken.



NOTICE

This describes a situation in which the product or devices could be damaged and also provides information on preventive measures that can be taken. It also highlights areas within the text that are of particular importance.



INFORMATION

This gives advice on applications and provides information on special features.

Safety

Intended use

The safety functions of the safety switch are:

- ▶ Safe shutdown of safety outputs when the actuator is removed beyond the assured release distance s_{ar} or when the actuator is not detected
- ▶ Remain shut down safely after the actuator has been removed

The safety switch meets the requirements in accordance with:

- ▶ EN 60947-5-3: PDDb with one of the approved actuators
- ▶ EN 62061: SIL CL 3
- ▶ EN ISO 13849-1: PL e (Cat. 4)
- ▶ EN ISO 14119: Coding level Low, type 4

The safety switch may only be used with one of the approved actuators.

The safety level PL e (Cat. 4)/SIL CL 3 is only achieved if

- ▶ the safety outputs use 2-channel processing.

The following is deemed improper use in particular

- ▶ Any component, technical or electrical modification to the product,
- ▶ Use of the product outside the areas described in this manual,
- ▶ Use of the product outside the technical details (see [Technical details](#)  30).



NOTICE

EMC-compliant electrical installation

The product is designed for use in an industrial environment. The product may cause interference if installed in other environments. If installed in other environments, measures should be taken to comply with the applicable standards and directives for the respective installation site with regard to interference.

Approved actuators:

- ▶ PSEN cs5.1
- ▶ PSEN cs5.1 low profile glue
- ▶ PSEN cs5.1 low profile screw

Safety regulations

Safety assessment

Before using a device it is necessary to perform a safety assessment in accordance with the Machinery Directive.

Functional safety is guaranteed for the product as a single component. However, this does not guarantee the functional safety of the overall plant/machine. In order to achieve the required safety level for the overall plant/machine, define the safety requirements for the plant/machine and then define how these must be implemented from a technical and organisational standpoint.

Use of qualified personnel

The products may only be assembled, installed, programmed, commissioned, operated, maintained and decommissioned by competent persons.

A competent person is a qualified and knowledgeable person who, because of their training, experience and current professional activity, has the specialist knowledge required. To be able to inspect, assess and operate devices, systems and machines, the person has to be informed of the state of the art and the applicable national, European and international laws, directives and standards.

It is the company's responsibility only to employ personnel who

- ▶ Are familiar with the basic regulations concerning health and safety / accident prevention,
- ▶ Have read and understood the information provided in the section entitled Safety
- ▶ Have a good knowledge of the generic and specialist standards applicable to the specific application.

Warranty and liability

All claims to warranty and liability will be rendered invalid if

- ▶ The product was used contrary to the purpose for which it is intended,
- ▶ Damage can be attributed to not having followed the guidelines in the manual,
- ▶ Operating personnel are not suitably qualified,
- ▶ Any type of modification has been made (e.g. exchanging components on the PCB boards, soldering work etc.).

Disposal

- ▶ In safety-related applications, please comply with the mission time T_M in the safety-related characteristic data.
- ▶ When decommissioning, please comply with local regulations regarding the disposal of electronic devices (e.g. Electrical and Electronic Equipment Act).

For your safety**WARNING!****Loss of safety function due to manipulation of the interlocking device**

Manipulation of the interlocking device may lead to serious injury and death.

- You should prevent any possibility of the interlocking device being manipulated through the use of a spare actuator.
- Keep the substitute actuator in a safe place and protect it from unauthorised access.
- If spare actuators are used, these must be installed as described in [Installation](#) [ 21].
- If the original actuators are replaced with substitute actuators, the original actuators must be destroyed before disposal.

- ▶ Do not remove the connector's protective cap until you are just about to connect the unit. This will prevent potential contamination.

Unit features

- ▶ Transponder technology for presence detection
- ▶ Pilz coding type: Coded
- ▶ Dual-channel operation
- ▶ 2 safety outputs
- ▶ 1 signal output
- ▶ LED display for:
 - State of the actuator
 - State of the inputs (always lights up yellow)
 - Supply voltage/fault
- ▶ 4 actuation directions, each with 3 approach directions (see [Explanation of markings](#) [ 10])
 - Square marking for normal operating distance
 - Triangle marking for short operating distance
 - 2 semicircle markings for a lateral approach. Please note the Lateral and vertical offset with the lateral approach to the semicircle marking.

The guaranteed safe operating distances for the specified selections only apply when the actuator approaches the switch vertically. With the other approach directions, the operating distances may sometimes be considerably larger (particularly when approaching the semicircle).

Function description

Basic function

The safety outputs may have a high or low signal, depending on the position of the actuator.

State of the outputs:

Actuator in the re- sponse range	Safety output 12	Safety output 22	Signal output Y32
Yes	High	High	High
No	Low	Low	Low

Block diagram

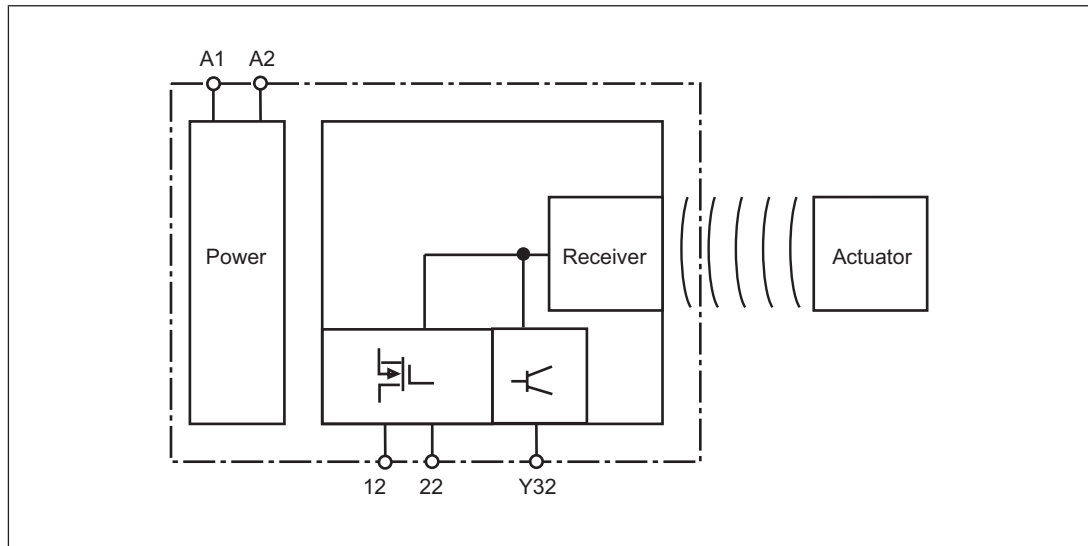

Operating distances

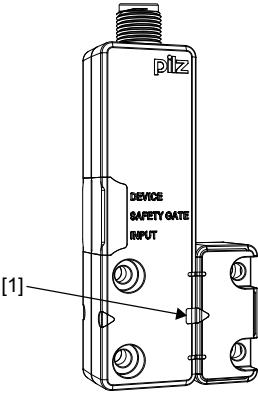
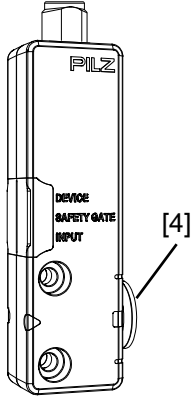
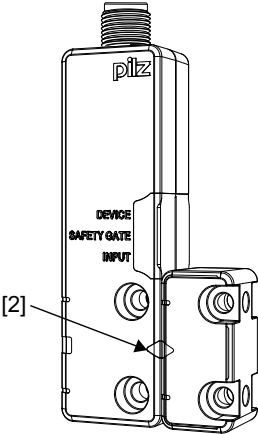
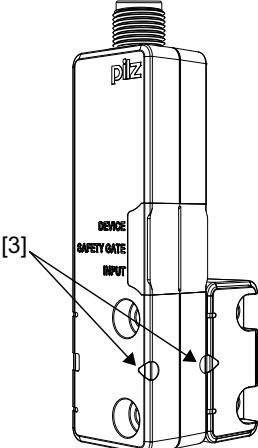
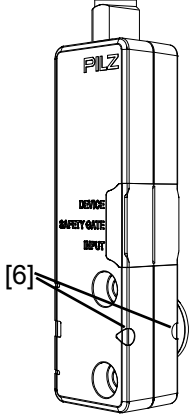
Actuator PSEN cs5.1	Actuator PSEN cs5.1 low profile glue or PSEN cs5.1 low pro- file screw	Operating distances
 <p>[1]</p>	 <p>[4]</p>	<p>[1] Actuator PSEN cs5.1 aligned to the square marking on the switch</p> <p>S_{ao} Assured operating distance: 8 mm S_{ar} Assured release distance: 20 mm S_o Typical operating distance: 11 mm S_r Typical release distance: 14 mm</p> <p>[4] Actuator PSEN cs5.1 low profile glue or PSEN cs5.1 low profile screw aligned to the square marking on the switch</p> <p>S_{ao} Assured operating distance: 5 mm S_{ar} Assured release distance: 20 mm S_o Typical operating distance: 10 mm S_r Typical release distance: 12 mm</p>
 <p>[2]</p>		<p>[2] Actuator PSEN cs5.1 aligned to the triangle marking on the switch</p> <p>S_{ao} Assured operating distance: 4 mm S_{ar} Assured release distance: 12 mm S_o Typical operating distance: 5 mm S_r Typical release distance: 8 mm</p> <p>The alignment of the actuators PSEN cs5.1 low profile glue or PSEN cs5.1 low profile screw to the triangle marking is not provided for</p>
 <p>[3]</p>	 <p>[6]</p>	<p>[3] Actuator PSEN cs5.1 aligned to the semicircle marking on the switch</p> <p>S_{ao} Assured operating distance: 3 mm S_{ar} Assured release distance: 16 mm S_o Typical operating distance: 6 mm S_r Typical release distance: 8 mm</p> <p>[6] Actuator PSEN cs5.1 low profile glue or PSEN cs5.1 low profile screw aligned to the semicircle marking on the switch</p> <p>S_{ao} Assured operating distance: 2 mm S_{ar} Assured release distance: 14 mm S_o Typical operating distance: 5 mm S_r Typical release distance: 7 mm</p>

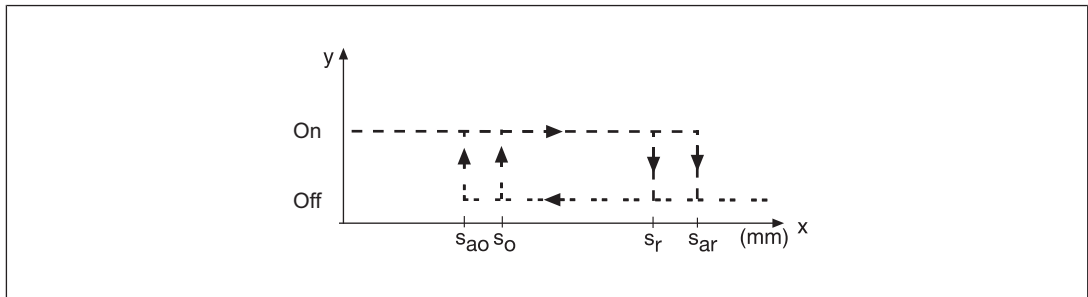

The switching distances of the actuators PSEN cs5.1 low profile glue and PSEN cs5.1 low profile screw were determined under the following conditions:

- ▶ Assured operating distance S_{ao} and assured release distance S_{ar}
 - Measurement over the entire temperature range
 - Installed on various base materials
 - Taking into account product tolerances
- ▶ Typical operating distance S_o and typical release distance S_r
 - Measured at room temperature
 - Installed on plastic

Lateral and vertical offset

Lateral offset when aligning to the triangle or square marking

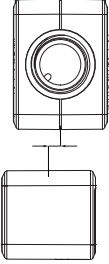
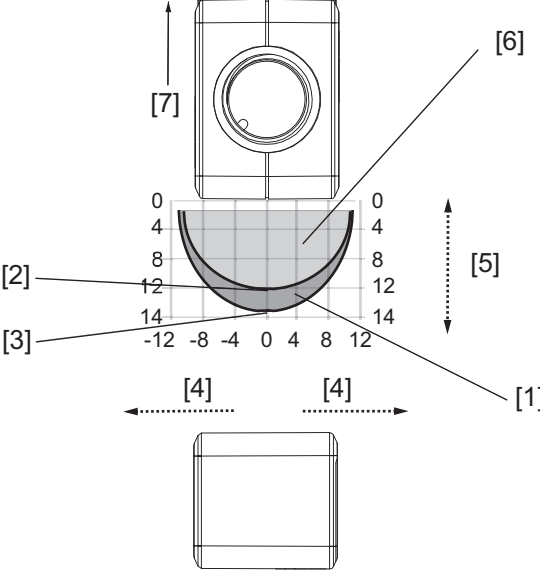
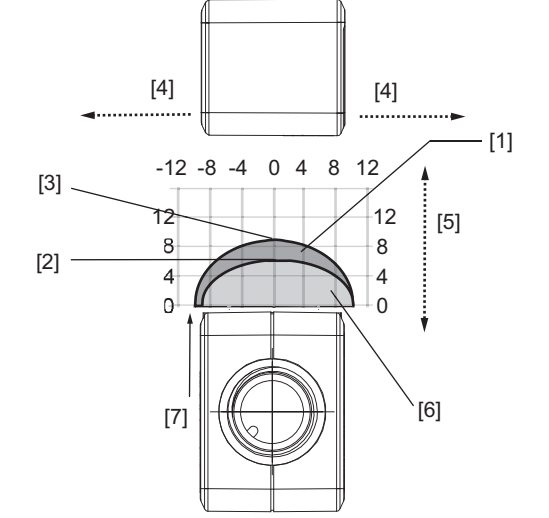
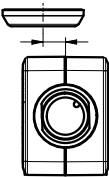
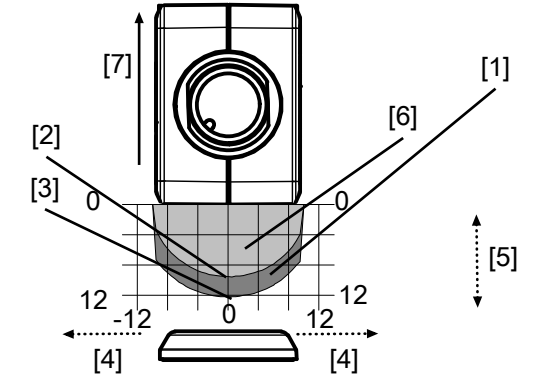
	Alignment 1: Actuator PSEN cs5.1 aligned to the square marking on the switch	Alignment 2: Actuator PSEN cs5.1 aligned to the triangle marking on the switch
		
	Alignment 1: Actuator PSEN cs5.1 low profile glue or PSEN cs5.1 low profile screw aligned to the square marking on the switch	Alignment 2: Actuator PSEN cs5.1 low profile glue or PSEN cs5.1 low profile screw aligned to the triangle marking on the switch
		<p>Actuator PSEN cs5.1 low profile glue or PSEN cs5.1 low profile screw to triangle marking is not suitable because the operating distances are too low.</p>

Legend

- [1] Hysteresis
- [2] Typical operating distance S_o
- [3] Typical release distance S_r
- [4] Offset in mm
- [5] Operating distance in mm
- [6] Response range
- [7] Status of LED

Lateral offset when aligning to the semicircle marking

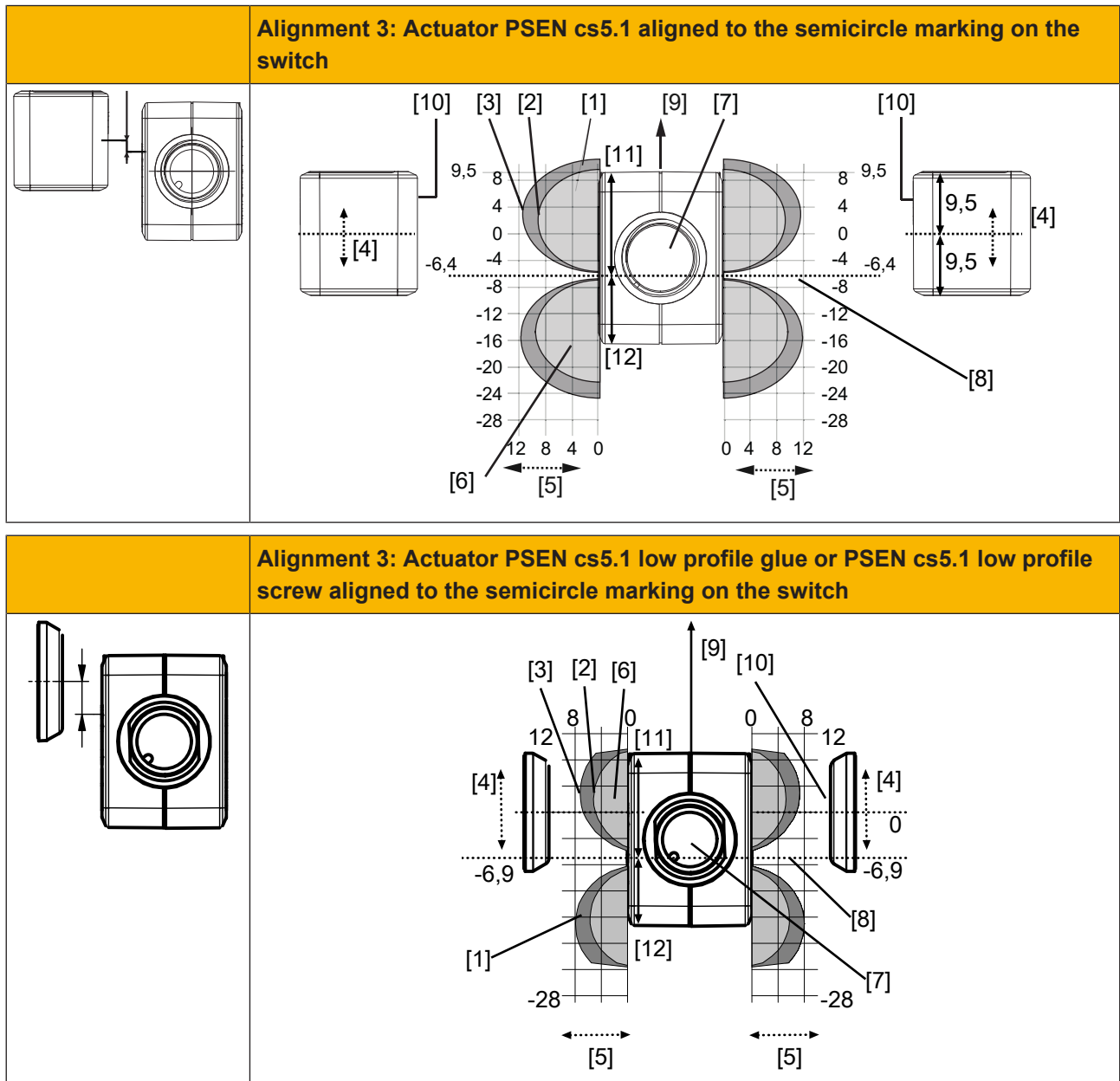

Legend

- [1] Hysteresis
- [2] Typical operating distance S_o
- [3] Typical release distance S_r
- [4] Offset in mm (distance of the middle of the actuator to the zero line in the grid)
- [5] Operating distance in mm
- [6] Response range
- [7] Connector on the safety switch
- [8] Limit of response range, position of gate hinge
- [9] Status of LED
- [10] Sensing face of the actuator, labelled with Pilz logo
- [11] Distance from the front edge of the safety switch to the limit of the response range (position of the gate end stop) = 15.9 mm
- [12] Distance from the front edge of the safety switch to the limit of the response range (position of the gate end stop) = 15.9 mm

[12] Distance from the rear edge of the safety switch to the limit of the response range (position of the gate end stop) = 10.5 mm

Vertical offset when aligning to the triangle or square marking

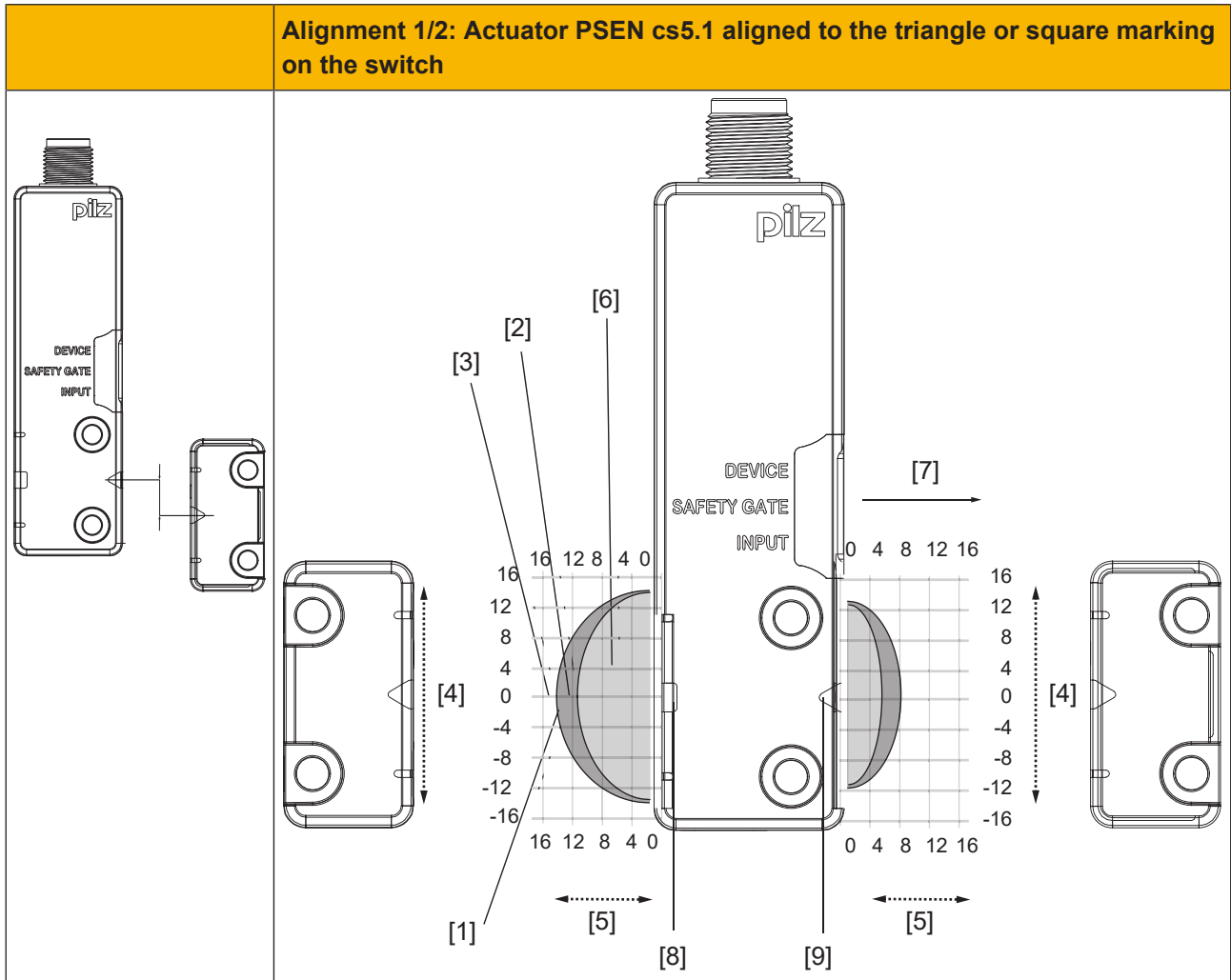

Alignment 1/2: Actuator PSEN cs5.1 low profile glue or PSEN cs5.1 low profile screw aligned to the square marking on the switch

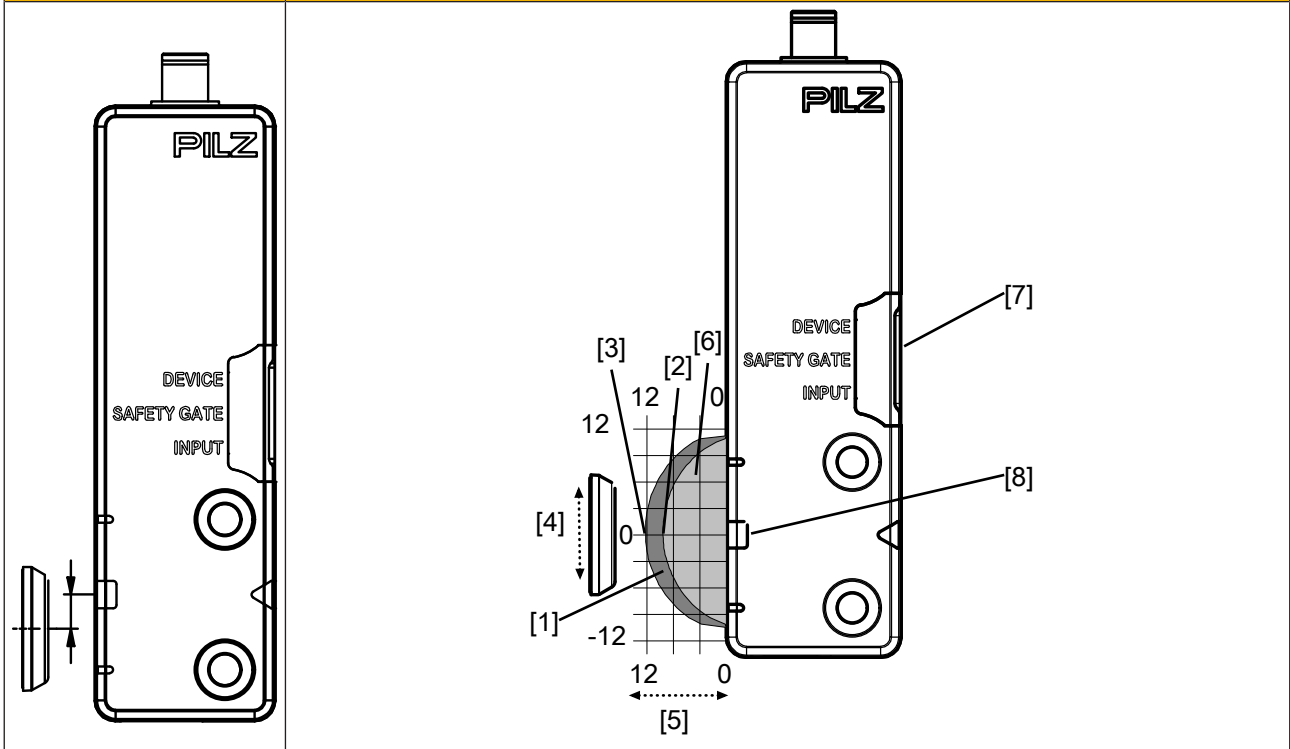

Legend

- [1] Hysteresis
- [2] Typical operating distance S_o
- [3] Typical release distance S_r
- [4] Offset in mm
- [5] Operating distance in mm
- [6] Response range
- [7] Status of LED
- [8] Square marking
- [9] Triangle marking

Vertical offset when aligning to the semicircle marking

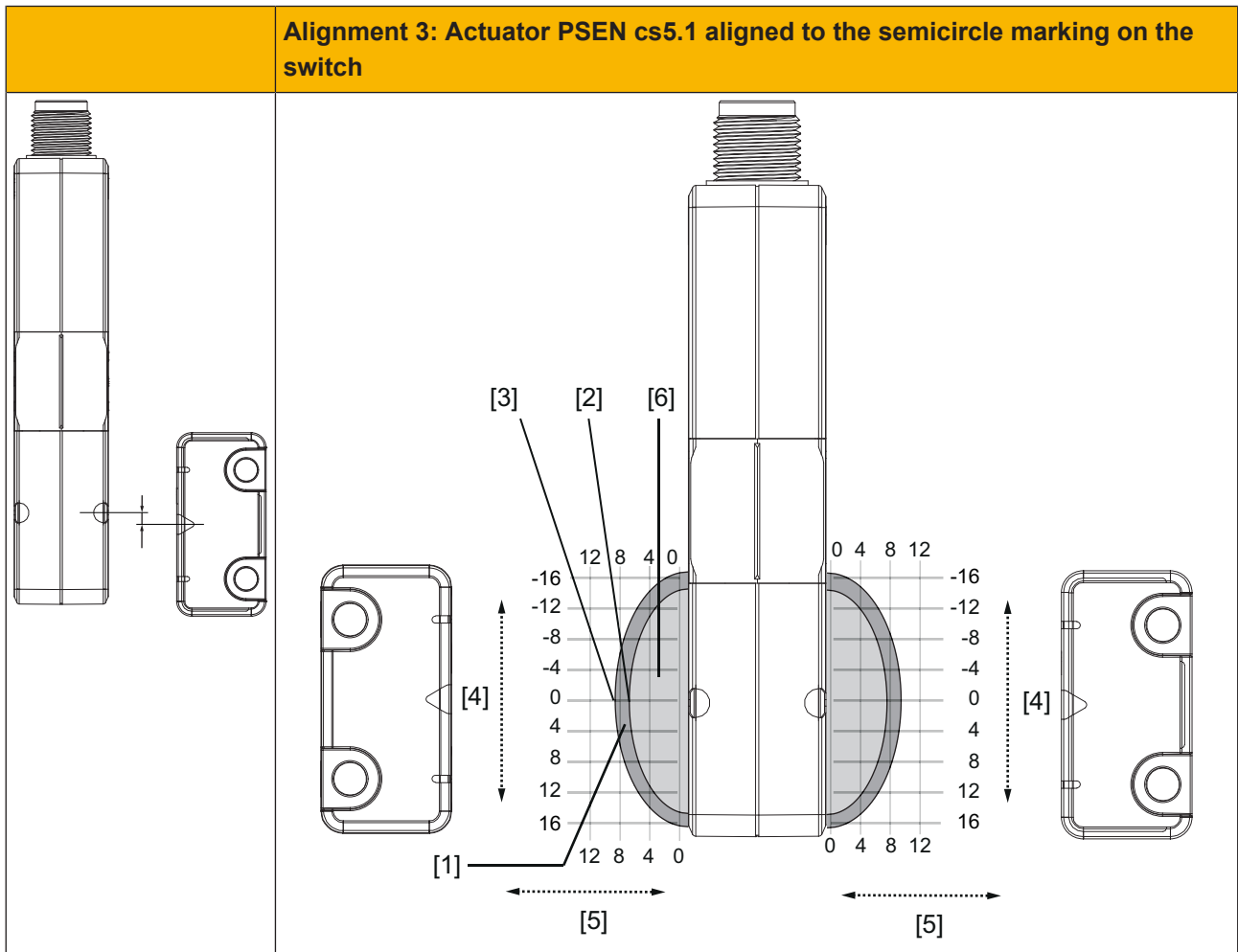

Alignment 3: Actuator PSEN cs5.1 low profile glue or PSEN cs5.1 low profile screw aligned to the semicircle marking on the switch

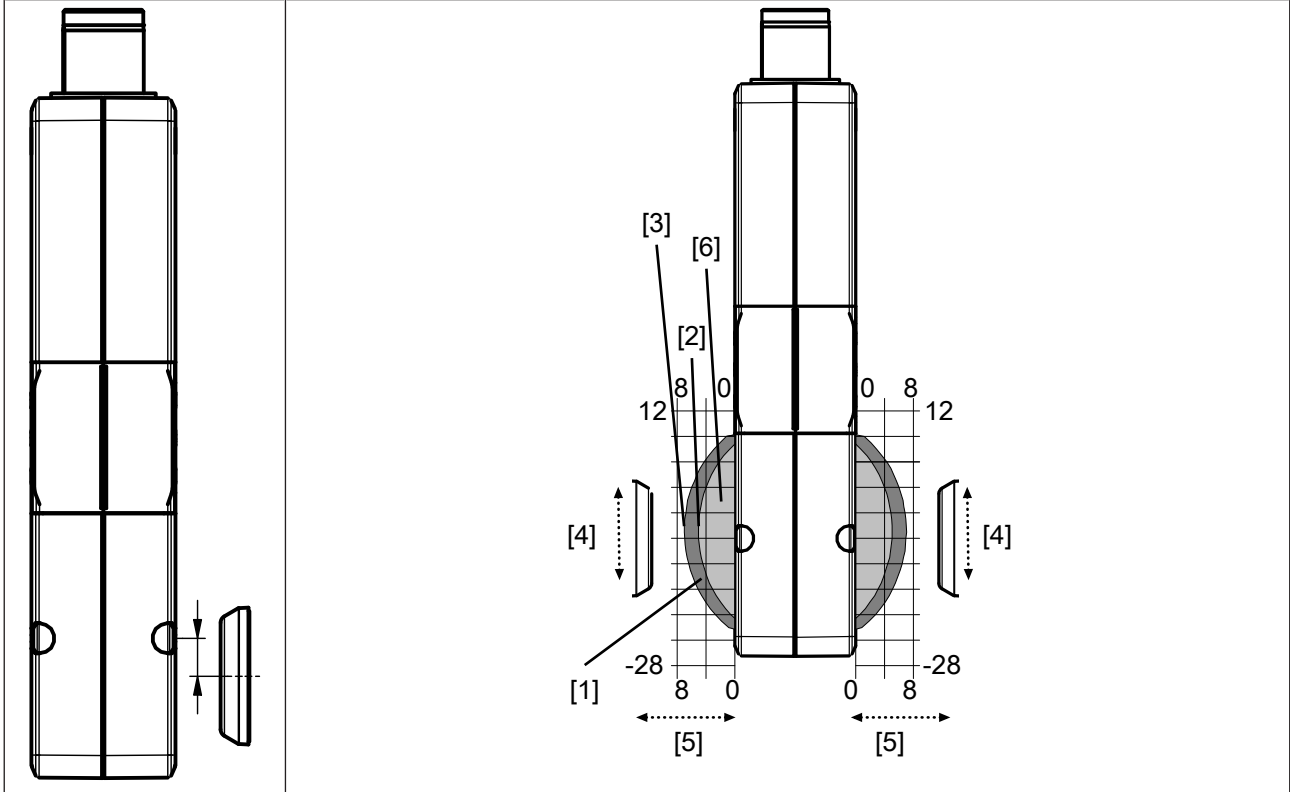

Legend

- [1] Hysteresis
- [2] Typical operating distance S_o
- [3] Typical release distance S_r
- [4] Offset in mm
- [5] Operating distance in mm
- [6] Response range

Wiring

Important information

- ▶ Information given in the [Technical details \[30\]](#) must be followed.
- ▶ Switch off the supply voltage before disconnecting the plug-in connection.
- ▶ Make sure that when connecting or separating the connector the pollution degree 1 or 2 is maintained.
- ▶ The power supply must meet the regulations for extra low voltages with protective electrical separation (SELV, PELV).
- ▶ The outputs of the safety switch must have a protective separation to voltages over 60 V AC.
- ▶ The supply voltage to the safety switch must be protected with a 2 A to 4 A quick-acting fuse.
- ▶ Ensure the wiring and EMC requirements of EN 60204-1 are met.

Pin assignment, connector and cable

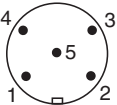
	5-pin M12 male connector
--	--------------------------

PIN	Pin designation	Function	Wire colour
1	A1	+24 V UB	brown
2	12	Output, channel1	white
3	A2	0 V UB	blue
4	22	Output, channel2	black
5	Y32	Signal output	grey

The wire colour also applies for the cable available from Pilz as an accessory.

Connection to evaluation devices

Make sure that the selected evaluation device has the following properties:

- ▶ 2-channel with feasibility monitoring
- ▶ OSSD signals are evaluated

Single connection



CAUTION!

Do not connect the signal output to 0 V!

If the signal output Y32 is connected to 0 V, the safety switch may be damaged as a result. Connect the signal output Y32 to a consumer, e.g. to the input on a control system, or leave the signal output unconnected. Also note the max. current (see [Technical details](#) [30]).

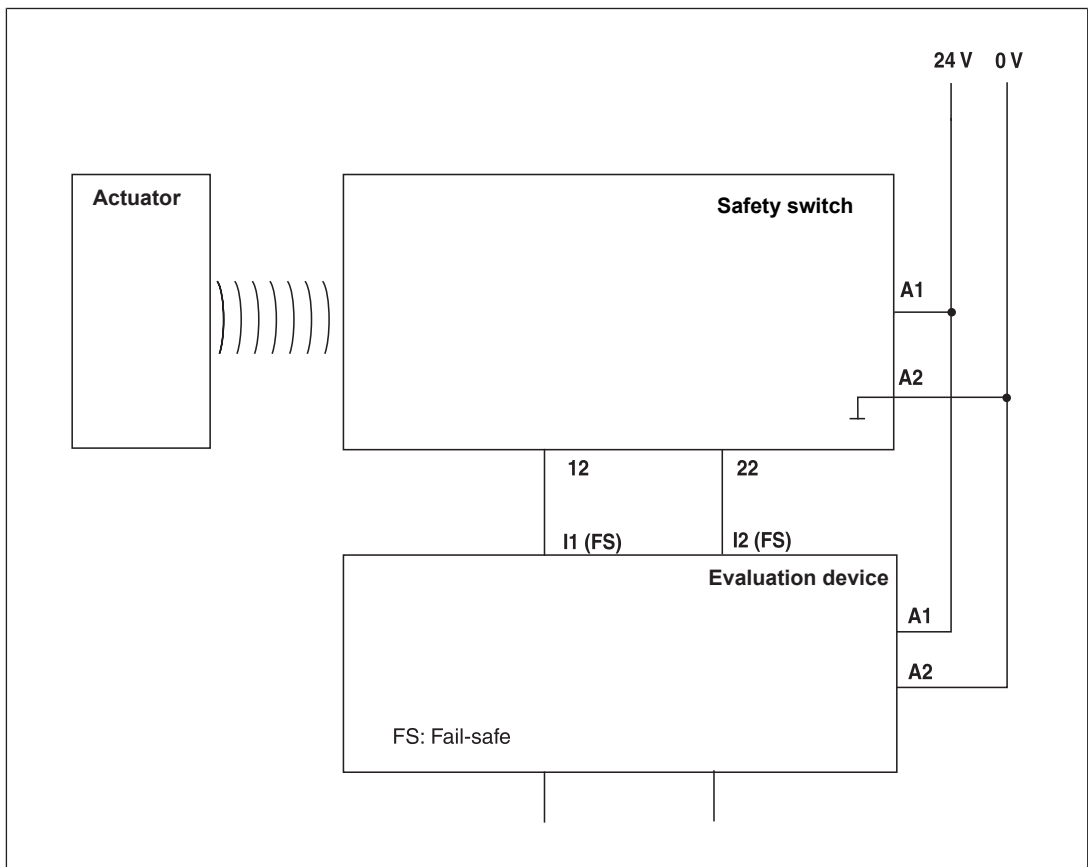

Connection to Pilz evaluation devices

The safety switch PSEN cs5.1n can be connected to Pilz evaluation devices, for example.

Suitable Pilz evaluation devices are, for example:

- ▶ PNOZelog for safety gate monitoring
- ▶ PNOZpower for safety gate monitoring
- ▶ PNOZsigma for safety gate monitoring
- ▶ PNOZ X for safety gate monitoring
- ▶ PNOZmulti for safety gate monitoring
Configure the safety switch in the PNOZmulti Configurator with switch type 3.
- ▶ PSS for safety gate monitoring with standard function block SB064, SB066 or FS_Safety Gate

The correct connection to the respective evaluation device is described in the operating manual for the evaluation device. Make sure that the connection is made in accordance with the specifications in the operating manual for the selected evaluation device.

The connections to two evaluation devices are shown on the following pages, by way of example:

- ▶ PNOZ s3 and
- ▶ PNOZmulti

PNOZ s3

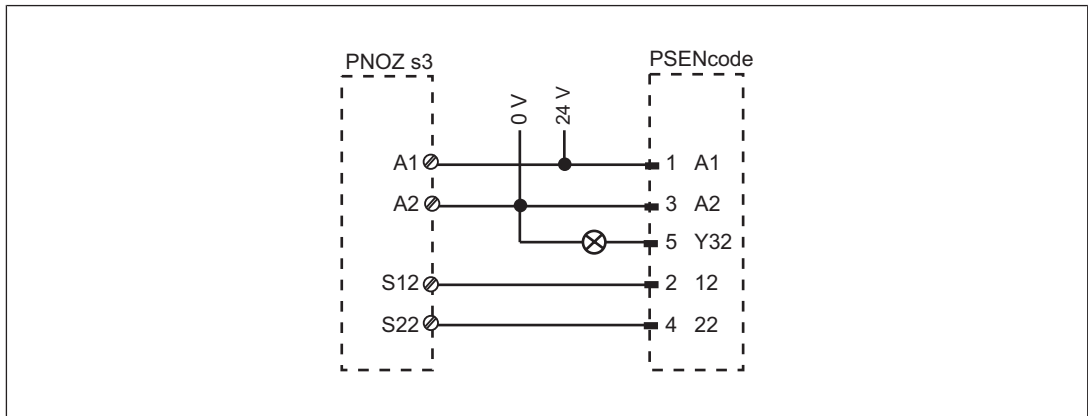

PNOZmulti

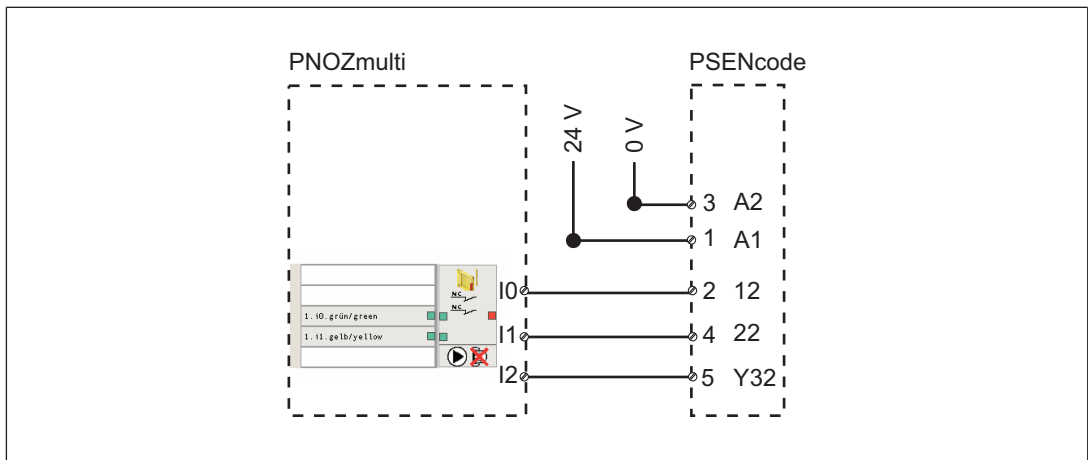

Teaching in the actuator

Any approved Pilz actuator (see Intended use) is detected as soon as it is brought into the response range.

Installation

General



CAUTION!

Potential loss of safety function due to changed device properties

The unit's properties may be affected if installed in an environment containing electrically or magnetically conductive material.

- Please check the operating distances and the assured release distance.

- ▶ The safety switch and actuator should be installed opposite each other in parallel. Make sure that the actuator is aligned to the marking on the safety switch that guarantees the operating distance required by the plant design (see [Operating distances](#) [10]).
- ▶ Torque setting: Please note the information provided under [Technical details](#) [30].
- ▶ The distance between two safety switches must be maintained (see [Technical details](#) [30]).
The distance can be undershot in certain application cases (see diagrams).

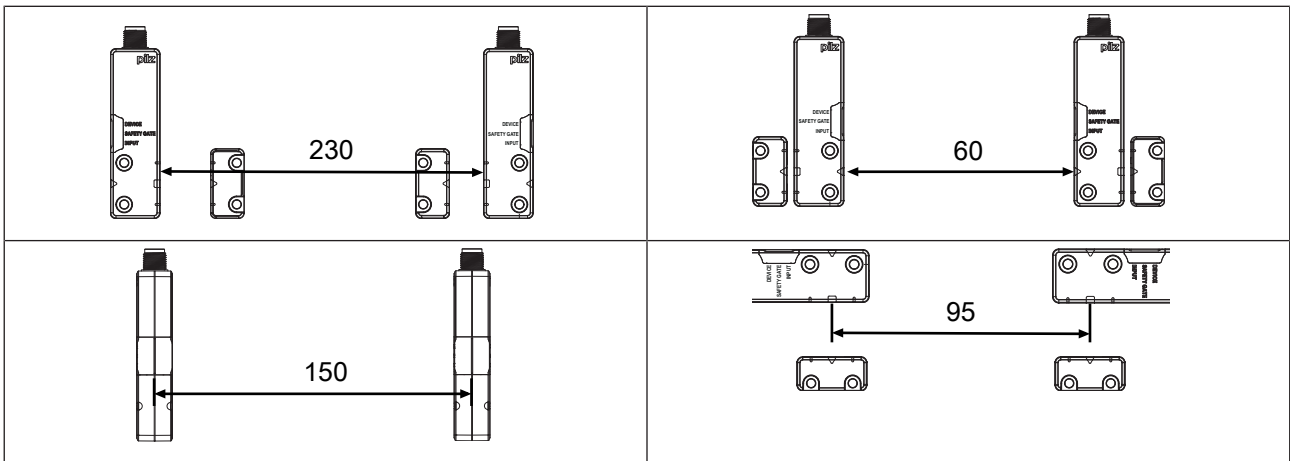

- ▶ Make sure that the safety switch and actuator cannot be used as an end stop.
- ▶ Please note the installation measures in accordance with EN ISO 14119 for a safety switch design 4 and with level of coding Low.
- ▶ Please note the permitted bending radii for the cable (see [Technical details](#) [30]), to avoid excessive force on the individual strands.
- ▶ Make sure that the bend protection is not damaged. Such damage can cause the whole product to fail.
- ▶ For simpler installation, the mounting brackets (see [Order reference for Accessories](#) [39]) can be used.



WARNING!

Loss of safety function due to non-permitted enlargement of the assured release distance when using both switching lobes (aligned at semicircle marking)

Depending on the application, serious injury or death may result.

- Install a mechanical stop when using the response range at the semi-circle marking, to avoid unintended switching off at the limit of the response range and to prevent the maximum release distance from enlarging impermissibly by using both switching lobes.

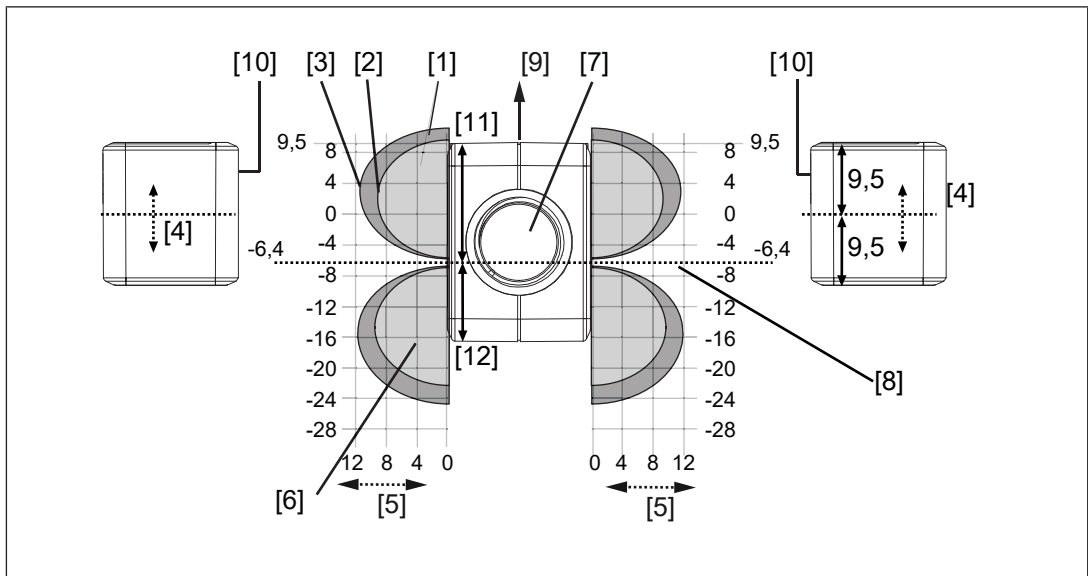

Legend

- [1] Hysteresis
- [2] Typical operating distance S_o
- [3] Typical release distance S_r
- [4] Offset in mm (distance of the middle of the actuator to the zero line in the grid)
- [5] Operating distance in mm
- [6] Response range
- [7] Connector on the safety switch
- [8] Limit of response range, position of gate hinge
- [9] Status of LED
- [10] Sensing face of the actuator, labelled with Pilz logo
- [11] Distance from the front edge of the safety switch to the limit of the response range (position of the gate end stop) = 15.9 mm
- [12] Distance from the rear edge of the safety switch to the limit of the response range (position of the gate end stop) = 10.5 mm

Safety switch

- ▶ Safety switches should only be secured using M4 screws with a flat head (e.g. M4 cheese-head or pan head screws).

Procedure:

1. Provide the mounting surface with two drill holes for fastening the safety switch (see [Dimensions in mm](#)  29]).
2. Use a screw to fix the safety switch to the mounting surface.
Make sure that the safety switch marking that is to be used for operation can be operated using the actuator from the right side.
3. Do not fully tighten the second screw on the safety switch.

Actuator 5.1**Procedure actuator PSEN cs5.1**

1. Provide the mounting surface with two drill holes for fastening the actuator (see [Dimensions](#)  29]).
2. Use a screw to fix the actuator to the mounting surface.
Make sure that the actuator with the marking (triangle) points towards the marking on the safety switch.
3. Do not fully tighten the second screw on the actuator.

Actuator 5.1 low profile**WARNING!****Loss of the manipulation protection by inadequate environmental conditions**

The loss of the manipulation protection can allow manipulation of the interlocking device and it may lead to serious injury or death.

- Make sure that the actuator has no direct or repetitive contact with materials such as methyl ethyl ketone (MEK), petrol or isopropanol.

- ▶ The actuator is secured against unauthorised removal, and against contamination by the sealing. The seal should be regarded as equivalent to using permanent fastenings in accordance with EN ISO 14119.
- ▶ By removing the actuator, the actuator will be destroyed.
- ▶ The actuator's adhesive force on the materials aluminium, stainless steel, polycarbonate and glass was checked. For deviating surface materials check the adhesive force on the surface.
- ▶ After a cure time of 24 hours, 90 % of the final adhesive force are achieved. The hardening must take place at min. 20 °C. With lower temperatures the cure time is clearly extended.
- ▶ No continuous force must affect the actuator.

Procedure actuator PSEN cs5.1 low profile glue:

1. To seal the low profile actuators correctly, it is necessary to prepare the surface to which the actuator is to be attached.

The surface must be clean, dry and free of grease.

Wipe off any solved grease and contaminations with a new, dry paper cloth.

Clean the surface with 70% isopropanol. Use lint-free paper cloths and change the paper cloths frequently.

The adhesive surface is clean when the paper remains clean.

The cleaned surfaces must be sealed immediately to prevent any new contamination by dust and fingerprints.

2. Remove the protective foil from the assembly aid and fix it flush with the sides (see diagram) to the required sensing area of the safety switch.
3. Place the actuator into the assembly aid so that the actuator's covered adhesive surface is on the surface.

Make sure that the actuator's centre is on the same level as the orientation arrows of the sensor and in the centre of the sensor.

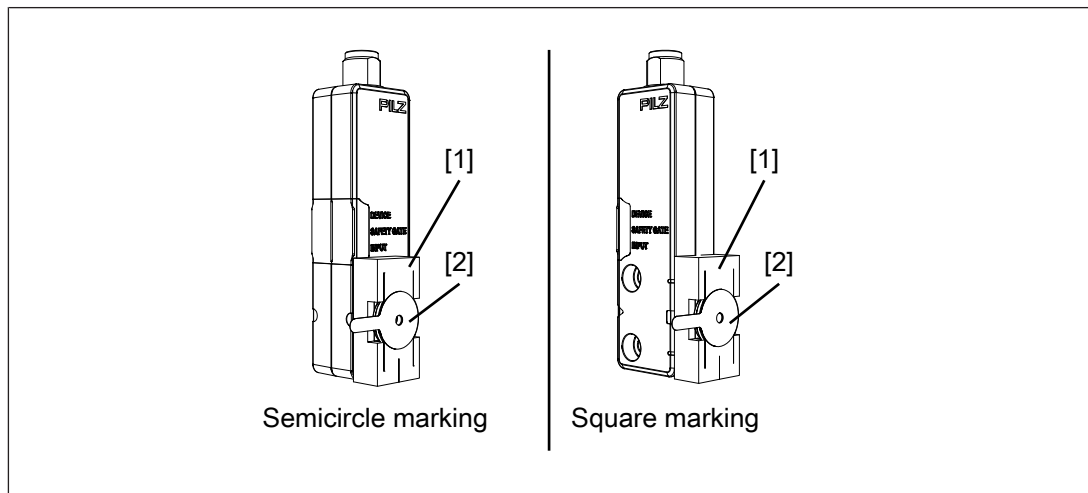

Fig.: Safety switch with assembly aid and low profile actuator oriented to semicircle and square marking

Legend

[1] Assembly aid for low profile actuator

[2] low profile actuator

4. Remove the protective foil from the adhesive foil of the actuator.
Do not touch the adhesive foil after removing the protective foil!
5. Then press the actuator firmly to the gluing position.
6. Press on the actuator for at least 3 seconds with approx. 50 N.
After this time, an adhesive force of approx. 50 % is achieved. The full adhesive force is achieved after 72 hours at an ambient temperature of at least 20 °C.
7. Check the adhesive force of the glue after 10 minutes.
The actuator must no move when pressed sideways.

8. Remove the assembly aid from the safety switch and clean the sensing area of the safety switch.

Procedure actuator PSEN cs5.1 low profile screw

1. Provide the mounting surface with a drill hole for an additional screw connection of the actuator (see [Dimensions in mm](#)  29).
2. To seal the low profile actuators correctly, it is necessary to prepare the surface to which the actuator is to be attached.

The surface must be clean, dry and free of grease.

Wipe off any solved grease and contaminations with a new, dry paper cloth.

Clean the surface with 70% isopropanol. Use lint-free paper cloths and change the paper cloths frequently.

The adhesive surface is clean when the paper remains clean.

The cleaned surfaces must be sealed immediately to prevent any new contamination by dust and fingerprints.

3. Remove the protective foil from the adhesive foil of the actuator.
Do not touch the adhesive foil after removing the protective foil!
4. Insert the screw into the actuator's hole and position the screw at the hole on the mounting surface.

To screw on the actuator, use the supplied plastic M3 countersunk screw.

When using a screw mad from metal the operating distance change, please note the [Warning](#)  21].

5. Tighten the M3 plastic screw to 1 Nm.
6. Press on the actuator for at least 3 seconds with approx. 50 N.
After this time, an adhesive force of approx. 50 % is achieved. The full adhesive force is achieved after 72 hours at an ambient temperature of at least 20 °C.
7. Check the adhesive force of the glue after 10 minutes.
The actuator must no move when pressed sideways.

Align safety switch and actuator

- ▶ The actuator should only be secured using M4 screws with a flat head (e.g. M4 cheese-head or pan head screws).

The actuator should be protected from unauthorised removal and from contamination. Close the mounting holes using the seals provided. The use of seals should be regarded as equivalent to using permanent fastenings in accordance with EN ISO 14119.

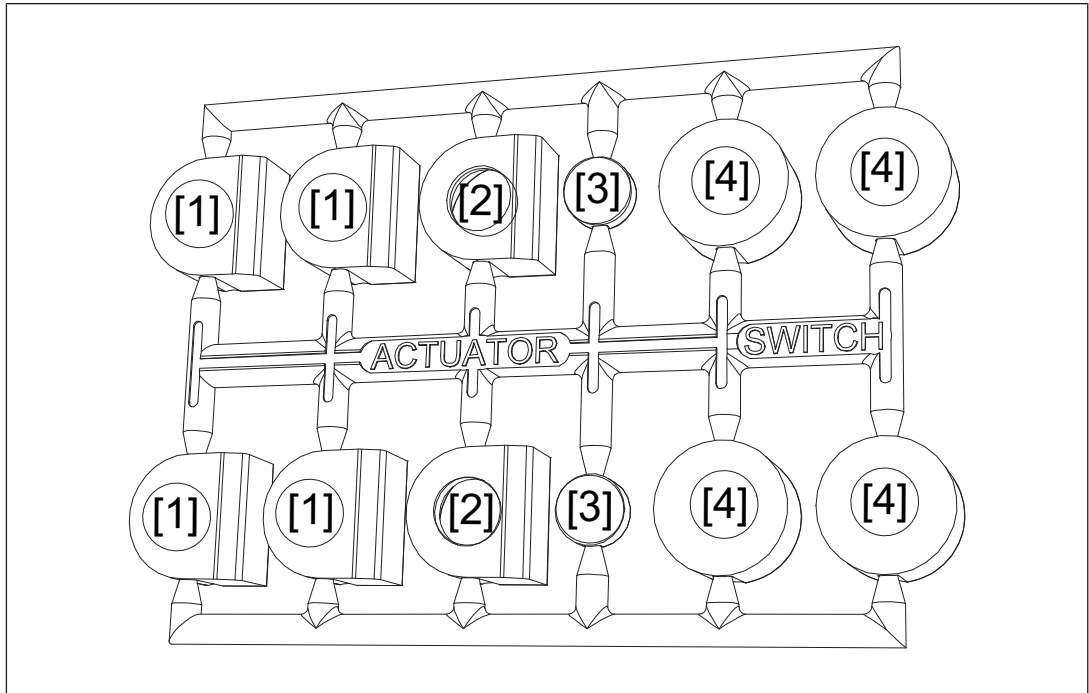

Legend

- [1] 4 seals for actuators
- [2] Unused seals
- [3] 2 seals for actuators
- [4] 2 seals for switches, 2 seals unused

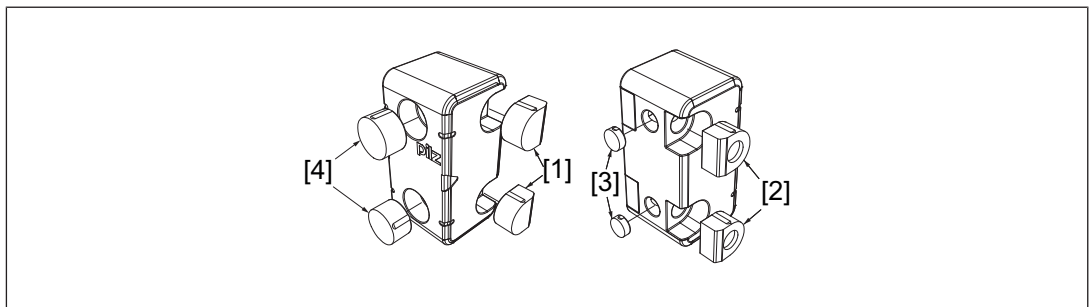

Fig.: Applying the screw covers [1] and [3] on the actuator

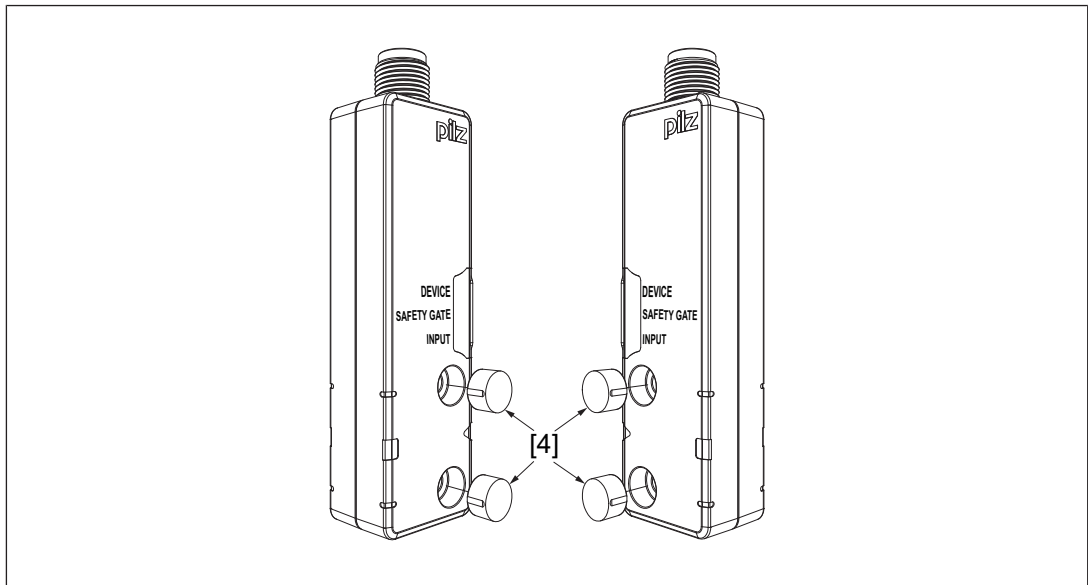

Fig.: Applying the screw cover [4] on the switch

Procedure:

1. Align the safety switch and tighten the screws.
2. Actuator PSEN cs5.1
Align the actuator and tighten the screws.
3. Use the seals to close the mounting holes on the sensing face of the safety switch (see diagram, [4]).

Use in operating heights higher than 2000 m above sea level

When using the PSEN cs5.1n note the reduced max. ambient temperature of +60 °C at a height of 2000 m to 4000 m.

Adjustment

- ▶ The stated operating distances (see [Technical details \[30\]](#)) only apply when the safety switch and actuator are installed facing each other in parallel. Operating distances may deviate if other arrangements are used.
- ▶ Note the maximum permitted lateral and vertical offset (see [Operating distances \[10\]](#) and [Lateral and vertical offset \[12\]](#)).

Operation



NOTICE

The safety function should be checked after initial commissioning and each time the plant/machine is changed. The safety functions may only be checked by qualified personnel.

Status indicators:

Legend







- LED off
- ☀ LED on
- ◐ LED flashes (500 ms on, 500 ms off)
- ◑ LED flashes quickly (50 ms on, 950 ms off)

Normal mode

LED status		Switch status
Device	☀ green	Ready for operation
Safety gate	☀ yel- low	Actuator is within the response range
	● Off	Actuator is outside the response range
Input	☀ yel- low	The unit is ready for operation

Error display

LED status			Switch status	Remedy / measure
Device	Safety Gate	Input		
☀ Red	● off	● off	Internal error on switch	Change the switch.
◐ Red	◐ Yellow	◐ Yellow	Supply voltage is outside the tolerance range	Ensure the voltage supply corresponds to the Technical details [30] .
◑ Yellow	Display not definitive	Display not definitive	Supply voltage is at the limit of the tolerance range	Ensure the voltage supply corresponds to the Technical details [30] .

LED status			Switch status	Remedy / measure
Device	Safety Gate	Input		
 Red	Display of last status	Display of last status	Outputs in fault condition	Check the outputs and switch the voltage off and then on again.
 Green	 Yellow	Display not definitive	Wrong actuator	Use the actuator that has been taught-in.
 off	 Yellow	 Yellow	Switch doesn't start	Change the switch.

Dimensions in mm

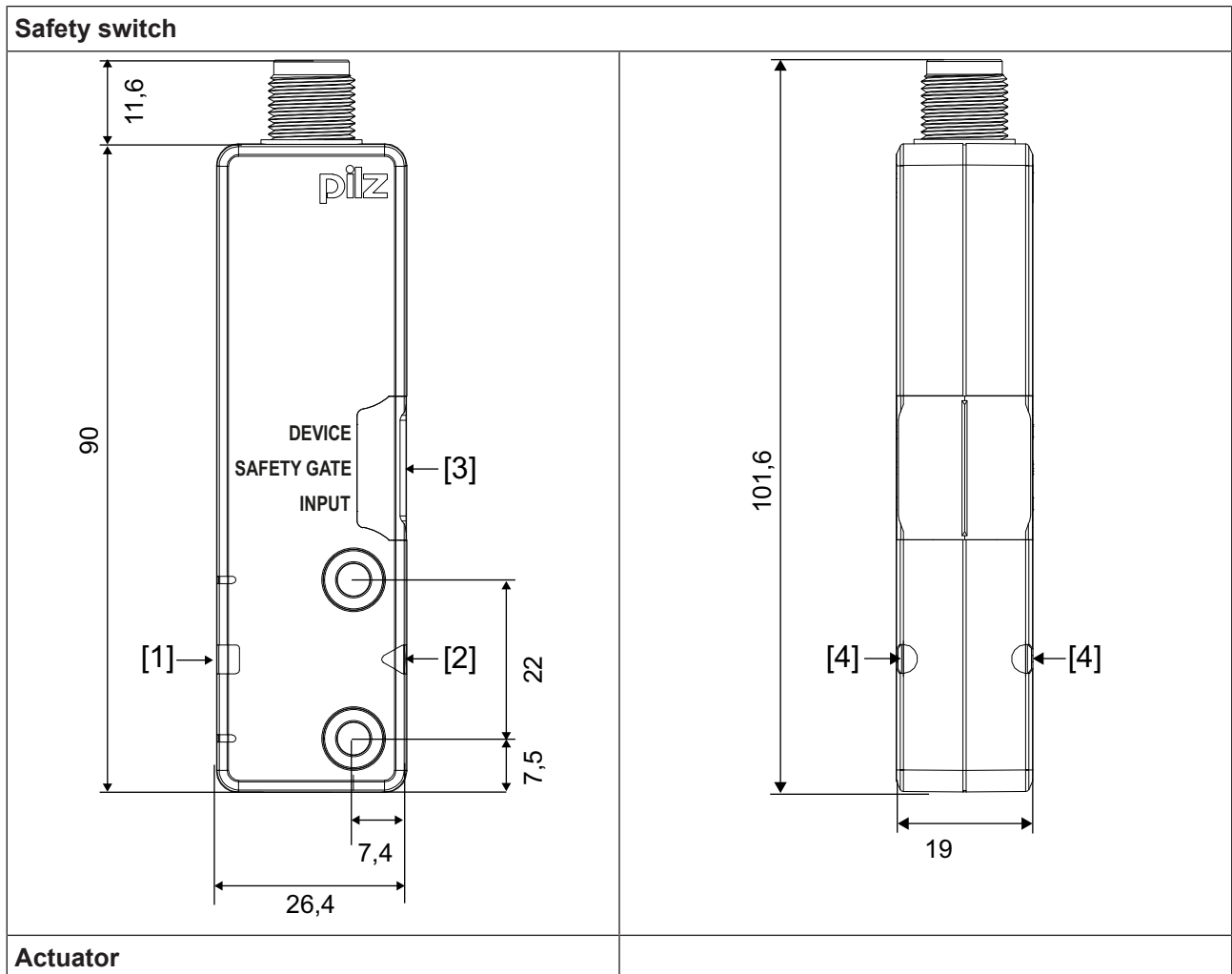

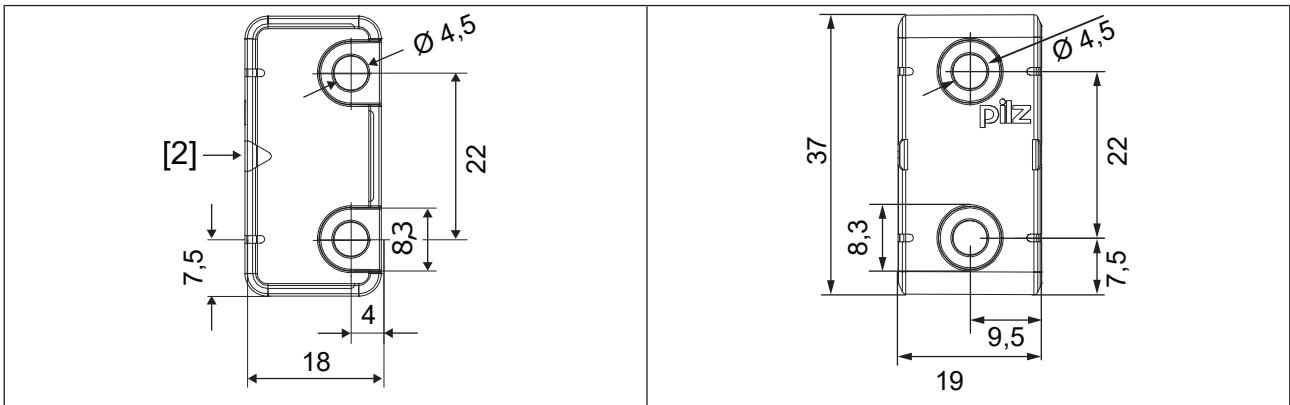

Legend:

- [1] Square marking
- [2] Triangle marking
- [3] LEDs
- [4] Semicircle marking

Actuator PSEN cs5.1 low profile glue	
Actuator PSEN cs5.1 low profile screw	

Technical details safety switch

General	
Certifications	CE, EAC (Eurasian), ECOLAB, FCC, IC, TÜV, cULus Listed
Sensor's mode of operation	Transponder
Coding level in accordance with EN ISO 14119	Low
Design in accordance with EN ISO 14119	4
Classification in accordance with EN 60947-5-3	PDDB
Pilz coding type	Coded

Transponder	
Frequency band	122 kHz - 128 kHz
Max. transmitter output	15 mW
Electrical data	
Supply voltage	
Voltage	24 V
Kind	DC
Voltage tolerance	-20 %/+20 %
Output of external power supply (DC)	1 W
Max. switching frequency	3 Hz
Max. cable capacitance at the safety outputs	
No-load, PNOZ with relay contacts	40 nF
PNOZmulti, PNOZelog, PSS	40 nF
Max. inrush current impulse	
Current pulse, A1	0,5 A
No-load current	25 mA
Semiconductor outputs	
OSSD safety outputs	2
Signal outputs	1
Switching current per output	100 mA
Breaking capacity per output	2,4 W
Potential isolation from system voltage	No
Short circuit-proof	yes
Residual current at outputs	400 µA
Voltage drop at OSSDs	1 V
Conditional rated short circuit current	100 A
Lowest operating current	2 mA
Utilisation category in accordance with EN 60947-1	DC-12
Times	
Test pulse duration, safety outputs	150 µs
Switch-on delay	
after UB is applied	1 s
Actuator typ.	30 ms
Actuator max.	50 ms
Delay-on de-energisation	
Actuator typ.	30 ms
Actuator max.	40 ms
Risk time in accordance with EN 60947-5-3	150 ms
Supply interruption before de-energisation	20 ms
Simultaneity, channel 1 and 2 max.	∞

Environmental data

Ambient temperature

In accordance with the standard	EN 60068-2-14
Temperature range	-25 - 70 °C
Max. at max. operating height	+60 °C
Max. at max. operating height <2000 m	+70 °C

Storage temperature

In accordance with the standard	EN 60068-2-1/-2
Temperature range	-40 - 85 °C

Climatic suitability

In accordance with the standard	EN 60068-2-30
Humidity	93 % r. h. at 40 °C

Max. operating height above sea level

4000 m

EMC

EN 60947-5-3

Vibration

In accordance with the standard	EN 60947-5-2
Frequency	10 - 55 Hz
Amplitude	1 mm

Shock stress

In accordance with the standard	EN 60947-5-2
Acceleration	30g
Duration	11 ms

Airgap creepage

Overvoltage category	III
Pollution degree	3

Rated insulation voltage

75 V

Rated impulse withstand voltage

1 kV

Protection type

Housing	IP66, IP67
---------	-------------------

Operating distances

Actuator 1

Type	PSEN cs5.1
Repetition accuracy switching distances	3 %
Change of operating distance with temperature changes	+0,02mm/°C

Actuator 2

Type	PSEN cs5.1 low profile glue
Repetition accuracy switching distances	3 %
Change of operating distance with temperature changes	+0,02mm/°C

Actuator 3

Type	PSEN cs5.1 low profile screw
Repetition accuracy switching distances	3 %
Change of operating distance with temperature changes	+0,02mm/°C

Operating distances when the actuator approaches square marking

Actuator 1

Type	PSEN cs5.1
Assured operating distance S_{ao}	8 mm
Assured release distance S_{ar}	20 mm
Typical operating distance S_o	11 mm
Typical release distance S_r	14 mm
Typical hysteresis	2 mm

Actuator 2

Type	PSEN cs5.1 low profile glue
Assured operating distance S_{ao}	5 mm
Assured release distance S_{ar}	20 mm
Typical operating distance S_o	10 mm
Typical release distance S_r	12 mm
Typical hysteresis	2 mm

Actuator 3

Type	PSEN cs5.1 low profile screw
Assured operating distance S_{ao}	5 mm
Assured release distance S_{ar}	20 mm
Typical operating distance S_o	10 mm
Typical release distance S_r	12 mm
Typical hysteresis	2 mm

Operating distances when the actuator approaches triangle marking

Actuator 1

Type	PSEN cs5.1
Assured operating distance S_{ao}	4 mm
Assured release distance S_{ar}	12 mm
Typical operating distance S_o	5 mm
Typical release distance S_r	8 mm
Typical hysteresis	2 mm

Operating distances when the actuator approaches semicircle marking

Actuator 1

Type	PSEN cs5.1
Assured operating distance S_{ao}	3 mm
Assured release distance S_{ar}	16 mm
Typical operating distance S_o	6 mm
Typical release distance S_r	8 mm
Typical hysteresis	2 mm

Operating distances when the actuator approaches semicircle marking

Actuator 2

Type	PSEN cs5.1 low profile glue
Assured operating distance Sao	2 mm
Assured release distance Sar	14 mm
Typical operating distance So	5 mm
Typical release distance Sr	7 mm
Typical hysteresis	2 mm

Actuator 3

Type	PSEN cs5.1 low profile screw
Assured operating distance Sao	2 mm
Assured release distance Sar	14 mm
Typical operating distance So	5 mm
Typical release distance Sr	7 mm
Typical hysteresis	2 mm

Mechanical data

Min. distance between safety switches	250 mm
Sensor flush installation in accordance with EN 60947-5-2	Yes, follow installation guidelines
Connection type	M12, 5-pin male connector
Material	PA+GF, PBT, polycarbonate
Max. torque setting for fixing screws	1 Nm
Dimensions	
Height	26,4 mm
Width	101,6 mm
Depth	19 mm
Weight	68 g

Where standards are undated, the 2015-11 latest editions shall apply.

Technical details actuator

Where standards are undated, the 2015-11 latest editions shall apply.

Order no. 542083 PSEN cs5.1

See below for more order numbers

General

Certifications	CE, EAC (Eurasian), ECOLAB, TÜV, cULus Listed
Sensor's mode of operation	Transponder
Coding level in accordance with EN ISO 14119	Low
Pilz coding type	Coded

Transponder

Frequency band	122 kHz - 128 kHz
----------------	--------------------------

Environmental data

Ambient temperature		
In accordance with the standard		EN 60068-2-14
Temperature range		-25 - 70 °C
Max. at max. operating height		+60 °C
Max. at max. operating height <2000 m		+70 °C
Storage temperature		
In accordance with the standard		EN 60068-2-1/-2
Temperature range		-40 - 85 °C
Climatic suitability		
In accordance with the standard		EN 60068-2-30
Humidity		93 % r. h. at 40 °C
Max. operating height above sea level		4000 m
EMC		EN 60947-5-3
Vibration		
In accordance with the standard		EN 60947-5-2
Frequency		10 - 55 Hz
Amplitude		1 mm
Shock stress		
In accordance with the standard		EN 60947-5-2
Acceleration		30g
Duration		11 ms
Protection type		
Housing		IP66, IP67

Mechanical data

Material		PBT
Max. torque setting for fixing screws		1 Nm
Dimensions		
Height		18 mm
Width		37 mm
Depth		19 mm
Weight		15 g

Order no. 542087 PSEN cs5.1 low profile glue

Order no. 542088 PSEN cs5.1 low profile screw

General	542087	542088
Certifications	CE, EAC (Eurasian), TÜV, cULus Listed	CE, EAC (Eurasian), TÜV, cULus Listed
Sensor's mode of operation	Transponder	Transponder
Coding level in accordance with EN ISO 14119	Low	Low
Pilz coding type	Coded	Coded
Transponder	542087	542088
Frequency band	122 kHz - 128 kHz	122 kHz - 128 kHz

Environmental data	542087	542088
Ambient temperature		
In accordance with the standard	EN 60068-2-14	EN 60068-2-14
Temperature range	-25 - 70 °C	-25 - 70 °C
Max. at max. operating height	+60 °C	+60 °C
Max. at max. operating height <2000 m	+70 °C	+70 °C
Storage temperature		
In accordance with the standard	EN 60068-2-1/-2	EN 60068-2-1/-2
Temperature range	-40 - 85 °C	-40 - 85 °C
Climatic suitability		
In accordance with the standard	EN 60068-2-30	EN 60068-2-30
Humidity	93 % r. h. at 40 °C	93 % r. h. at 40 °C
Max. operating height above sea level		
	4000 m	4000 m
EMC		
	EN 60947-5-3	EN 60947-5-3
Vibration		
In accordance with the standard	EN 60947-5-2	EN 60947-5-2
Frequency	10 - 55 Hz	10 - 55 Hz
Amplitude	1 mm	1 mm
Shock stress		
In accordance with the standard	EN 60947-5-2	EN 60947-5-2
Acceleration	30g	30g
Duration	11 ms	11 ms
Protection type		
Housing	IP67	IP67
Mechanical data	542087	542088
Material		
Top	PBT	PBT
Max. torque setting for fixing screws		
	–	0,1 Nm
Dimensions		
Height	3,8 mm	3,8 mm
Width	18 mm	18 mm
Depth	18 mm	18 mm
Weight		
	2 g	2 g

Classification according to ZVEI, CB24I

The following tables describe the classes and specific values of the product interface and the classes of interfaces compatible with it. The classification is described in the ZVEI position paper "Classification of Binary 24 V Interfaces - Functional Safety aspects covered by dynamic testing".

Single-pole output	
Interfaces	
Source	
Interface	Sensor
Class	C2
Drain	
Class	C1, C2
Source parameters	
Max. test pulse duration	150 µs
Max. rated current	0,1 A
Max. capacitive load	40 nF

Safety characteristic data



NOTICE

You must comply with the safety characteristic data in order to achieve the required safety level for your plant/machine.

Operating mode	EN ISO 13849-1: 2015	EN ISO 13849-1: 2015	EN 62061 SIL CL	EN 62061 PFH _D [1/h]	IEC 61511 SIL	IEC 61511 PFD	EN ISO 13849-1: 2015 T _M [year]
	PL	Category					
2-ch. OSSD	PL e	Cat. 4	SIL CL 3	9,56E-10	–	8,51E-06	20

Explanatory notes for the safety-related characteristic data:

- ▶ The SIL CL value in accordance with EN 62061 corresponds to the SIL value in accordance with EN 61508.
- ▶ T_M is the maximum mission time in accordance with EN ISO 13849-1. The value also applies as the retest interval in accordance with EN 61508-6 and IEC 61511 and as the proof test interval and mission time in accordance with EN 62061.

All the units used within a safety function must be considered when calculating the safety characteristic data.



INFORMATION

A safety function's SIL/PL values are **not** identical to the SIL/PL values of the units that are used and may be different. We recommend that you use the PAscal software tool to calculate the safety function's SIL/PL values.

Supplementary data

Radio approval

<u>USA/Canada</u>
<p>FC FCC ID: VT8-PSENC55 IC: 7482A-PSENC55</p> <p><u>FCC/IC-Requirements:</u> This product complies with Part 15 of the FCC Rules and with Industry Canada licence-exempt RSS standards. Operation is subject to the following two conditions: 1) this product may not cause harmful interference, and 2) this product must accept any interference received, including interference that may cause undesired operation.</p> <p>Changes or modifications made to this product not expressly approved by Pilz may void the FCC authorization to operate this equipment.</p> <p>NOTE: This equipment has been tested and found to comply with the limits for a Class A digital device, pursuant to Part 15 of the FCC Rules. These limits are designed to provide reasonable protection against harmful interference when the equipment is operated in a commercial environment. This equipment generates, uses, and can radiate radio frequency energy and, if not installed and used in accordance with the instruction manual, may cause harmful interference to radio communications. Operation of this equipment in a residential area is likely to cause harmful interference in which case the user will be required to correct the interference at his own expense.</p> <p>Le présent produit est conforme aux CNR d'Industrie Canada applicables aux appareils radio exempts de licence. L'exploitation est autorisée aux deux conditions suivantes: (1) le produit ne doit pas produire de brouillage, et (2) l'utilisateur de le produit doit accepter tout brouillage radioélectrique subi, même si le brouillage est susceptible d'en compromettre le fonctionnement.</p>

Order reference

Safety switch

Product type	Features		Order no.
PSEN cs5.1n 1switch	Safety switch, coded	5-pin M12 connector	542 053

Actuator

Product type	Features		Order no.
PSEN cs5.1 M12 1actuator	Actuator, coded		542 083
PSEN cs5.1 low pro- file glue 1 actuator	Actuator coded, without screw		542 087
PSEN cs5.1 low pro- file screw 1 actuator	Actuator coded, with screw		542 088

Complete systems

Product type	Features		Order no.
PSEN cs5.1n/PSEN cs5.1 M12 1unit	Safety gate system, coded	5-pin M12 connector	542 003

Accessories

Installation materials

Product type	Features	Order no.
PSEN bracket	Mounting bracket	532 110
PSEN mag/cs bracket straight	Mounting aid	532 111
PSEN screw M4x20 10pcs	Safety screws made from stainless steel with one-way slot	540 313
PSEN screw M4x26 10pcs	Safety screws made from stainless steel with one-way slot	540 314
PSEN cs1/2 bracket cable fix	Mechanical protection against defeat, protecting against unauthorised cable disconnection or damage for safety switches PSENcode cs1/2, PSENcode cs5/6 M12, PSENslock	532 112

Cable

Product type	Connection 1	Connection 2	Length	Order No.
PSS67/PDP67 cable M12-5sf	Straight, M12, 5-pin, socket	Straight, M12, 5-pin, connector	3 m	380 208
			5 m	380 209
			10 m	380 210
			20 m	380 220
			30 m	380 211
PSS67/PDP67 cable M12-5af	Angled, M12, 5-pin, socket	Angled, M12, 5-pin, connector	3 m	380 212
			5 m	380 213
			10 m	380 214
			30 m	380 215
PSEN cable M12-5sf	Straight, M12, 5-pin, socket	Open cable	3 m	630 310
			5 m	630 311
			10 m	630 312
			20 m	630 298
			30 m	630 297
PSEN cable M12-5af	Angled, M12, 5-pin, socket	Open cable	3 m	630 347
			5 m	630 348
			10 m	630 349
			30 m	630 350

Connection

Product type	Features	Order no.
PDP67 F 8DI ION	Decentralised input module IP67 for PNOZmulti with M12 thread	773 600
PDP67 F 8DI ION HP	Decentralised input module IP67 for PNOZmulti with M12 thread and additional supply voltage	773 601
PDP67 F 8DI ION VA	Decentralised input module IP67 for PNOZmulti with M12 thread in stainless steel	773 614
PDP67 F 8DI ION HP VA	Decentralised input module IP67 for PNOZmulti with M12 thread in stainless steel and additional supply voltage	773 615

EC declaration of conformity

This product/these products meet the requirements of the following directives of the European Parliament and of the Council.

- ▶ 2006/42/EC on machines
- ▶ 2014/53/EC on radio equipment

The complete EC Declaration of Conformity is available on the Internet at www.pilz.com/downloads.

Representative: Norbert Fröhlich, Pilz GmbH & Co. KG, Felix-Wankel-Str. 2, 73760 Ostfildern, Germany

