

Original operating instructions
Safe AS-i e-stop operating unit

UK

AC012S

80269313/00 08/2017

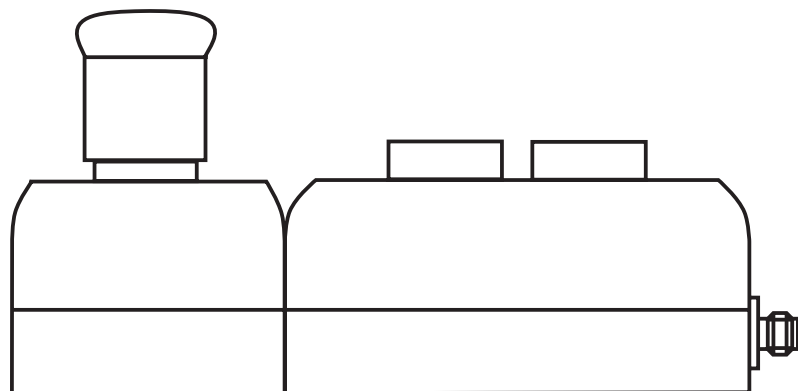

Contents

1 Preliminary note.....	3
1.1 Explanation of symbols.....	3
2 Safety instructions	3
2.1 Safety-related requirements regarding the application.....	4
3 Items supplied.....	4
4 Functions and features	4
5 Function and electrical connection	5
6 Installation.....	6
6.1 Operating and display elements	6
7 Electrical connection.....	7
8 Addressing.....	9
9 Operation	9
9.1 Response times	10
10 Safety characteristics.....	10
11 Technical data	11
12 Scale drawing	13
13 Troubleshooting	14
14 Maintenance, repair and disposal.....	14
15 Approvals/Certificates.....	14

1 Preliminary note

Technical data, approvals, accessories and further information at www.ifm.com.

The instructions are part of the unit. They are intended for authorised persons according to the EMC, Low Voltage and Machinery Directive and safety regulations. The instructions contain information about the correct handling of the product.

Read the instructions before use to familiarise yourself with operating conditions, installation and operation.

Adhere to the safety instructions.

UK

1.1 Explanation of symbols

▶ Request for action

 Important note

 **WARNING**

Warning of dangers which may lead to death or serious irreversible injuries.

2 Safety instructions

- Follow the operating instructions.
- In case of non-observance of notes or standards, especially when tampering with and/or modifying the unit, any liability and warranty is excluded.
- The unit must be installed, connected and put into operation by a qualified electrician trained in safety technology.
- The applicable technical standards for the corresponding application must be complied with.
- For installation the requirements according to EN 60204 must be observed.
- In case of malfunction of the unit please contact the manufacturer. Tampering with the unit is not allowed.
- Disconnect the unit externally before handling it. Also disconnect any independently supplied relay load circuits.
- After setup the system has to be subjected to a complete function check.
- In case of any questions - if required - contact the safety expert in charge of your country.

! WARNING

In case of improper handling of the product, the safety and physical integrity of operators and machinery cannot be guaranteed.

Death or serious irreversible injuries may result.

- ▶ Note all remarks on installation and handling given in these instructions.
- ▶ The device must only be used under the specified operating conditions and in accordance with use as prescribed below.

2.1 Safety-related requirements regarding the application

It must be ensured that the safety requirements of the respective application correspond to the requirements stated in these instructions.

Observe the following requirements:

- ▶ Adhere to EN 14119 for interlocking devices associated with guards.
- ▶ Adhere to the specified operating conditions (→ chapter 11 Technical data).
Use of the unit in the vicinity of chemical and biological media is not permitted.
- ▶ In case of faults within the unit which result in the defined safe state: take measures to maintain the safe state when the complete control system continues to be operated.
- ▶ Replace damaged units.

3 Items supplied

1 compact AS-i E-STOP safety module, 1 AC012S operating instructions with the reference number 80269313.

If one of the above-mentioned components is missing or damaged, please contact one of the ifm branch offices.

4 Functions and features

The safe compact AS-i E-STOP safety module consists of two AS-i slaves: one safe and one non-safe participant.

The compact AS-i E-STOP safety module (AC012S) is used to detect safety-related switching states. For this purpose a code table is transferred via the AS-i system with 8 x 4 bits which is evaluated by the safety monitor (e.g. AC001S ... AC004S, AC032S, AC041S).

When operated correctly, the system can be used in applications up to the Performance Level e according to EN ISO 13849-1 or IEC 61508/SIL3 (see notes Electrical connection). The additional buttons are used for the detection and control of non-safety-related switching states, such as Start / Stop.

 Depending on the safety components used the complete safety system can also be classified for a lower control category!

5 Function and electrical connection

Please refer to all information in the description of the configuration software (e.g. E7050S) and the installation instructions of the unit. These documents provide all required instructions concerning installation, configuration, operation and maintenance of the compact AS-i E-STOP safety module.

Information on the parameterizable safety functions of the compact AS-i E-STOP safety module can be found in the chapter "Monitoring devices" (**two positively guided NC contacts**) of the configuration software manual.

 The products described herein are designed to be components of a safety-oriented machine or control system. A complete safety-related system normally includes sensors, evaluation units, signalling components and concepts for safe switch-off. It is the responsibility of each manufacturer of a machine or installation to ensure a correct functioning of the whole system. The manufacturer of the safe AS-i module, his subsidiaries and affiliates are not in a position to evaluate all of the characteristics of a given machine or product not designed by him.

The manufacturer accepts no liability for any recommendation that may be implied or stated herein. The warranty contained in the contract of sale is the sole warranty. Any statements contained herein do not create new warranties or modify existing ones. Compliance with the description of the configuration software and with the operating instructions of the AS-i safety monitor and compact AS-i E-STOP safety module is mandatory!

 Maintenance requirement

A minimum of one testing per year is compulsory by a demand on the safety function!

6 Installation

- ▶ Fasten the compact AS-i E-STOP safety module onto a mounting device. The upper part of the housing must be fixed to the lower part using all 8 screws.
- ▶ Select one of the enclosed coloured button lenses and press it into the corresponding illuminated pushbutton (normally open).
- ▶ Select one of the enclosed coloured button disks and press it into the corresponding pushbutton (normally closed).

6.1 Operating and display elements

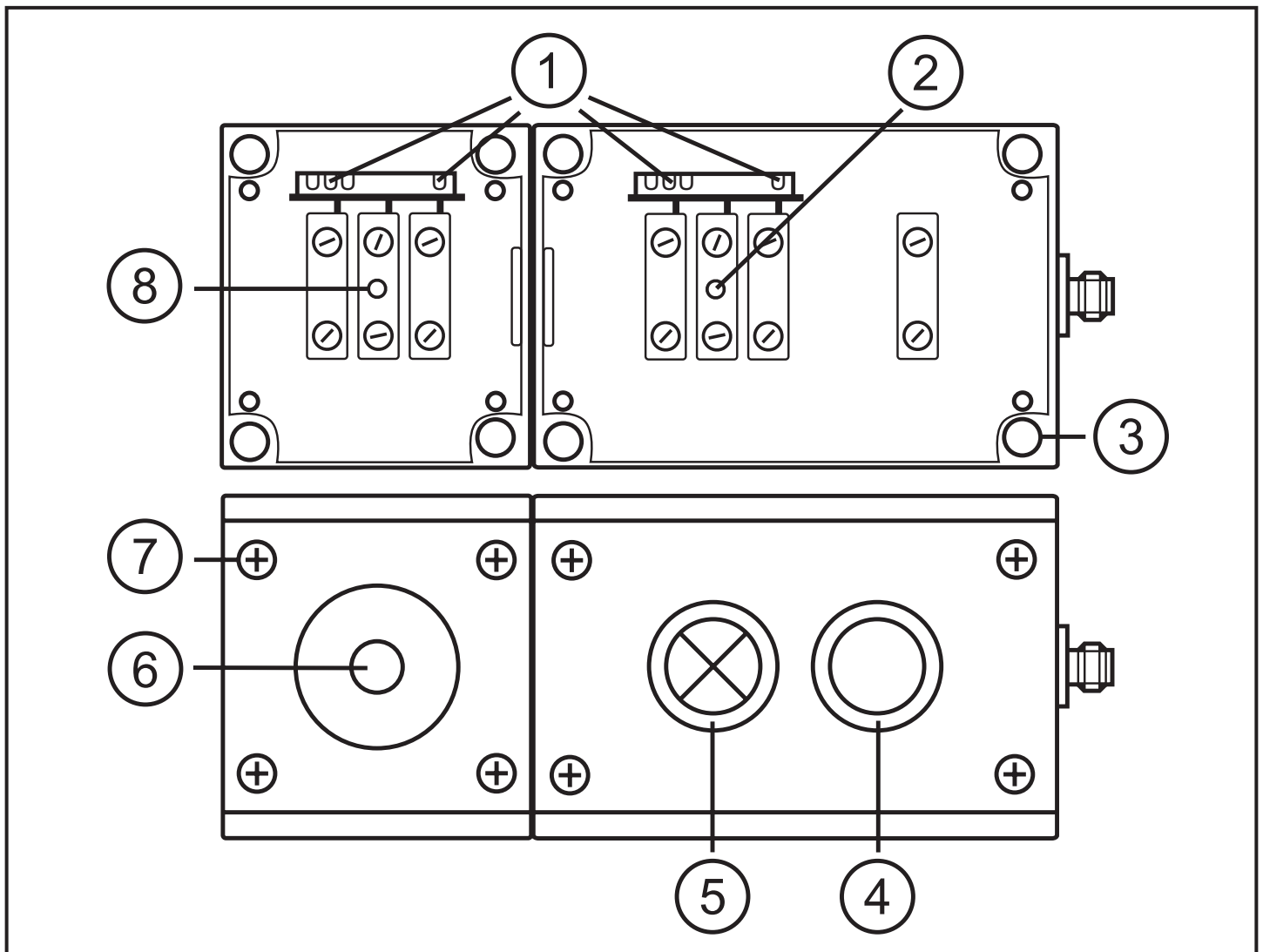

- 1: LEDs
- 2: LED non-safe AS-i slave
- 3: 8 mounting holes
- 4: pushbutton non-illuminated (normally closed)
- 5: pushbutton illuminated (normally open)
- 6: E-STOP, illuminated
fool-proof to ISO 13850; pull to reset
- 7: 8 fixing screws (upper part of the housing)
- 8: LED safe AS-i slave

7 Electrical connection



Connect the compact AS-i E-STOP safety module to the AS-i system via the M12 connector. The power comes from the AS-i system.

Do not connect the AS-i potential to an external potential.

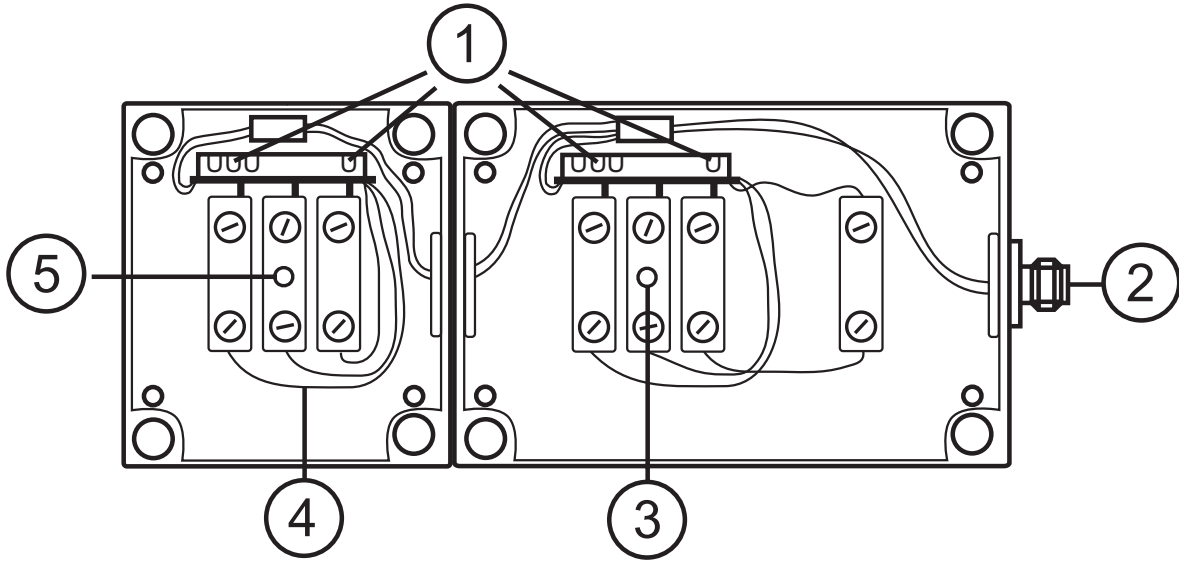

M12 connector		Pin
	AS-i +	1
	AS-i -	3

- 1: LED red / LED green / LED yellow (cannot be seen when the unit is closed)
- 2: M12 connector
- 3: LED white, non-safe AS-i slave
- 4: Do not change the electrical connections!
- 5: LED red, alarm output

UK

Data bits safe AS-i slave

Data bit	D3	D2	D1	D0
In / Out	SI-2	SI-2	SI-1	SI-1/O-1

Activated input channel	Bit sequence D3-D0
SI-1	XX00
SI-2	00XX
SI-1 and SI-2	0000
none	XXXX
Activated alarm output	Bit sequence D3-D0
O-1	XXX1

X = random

The code words 0000, XX00 and 00XX cause the AS-i safety monitor to bring the installation into the safe state.

For more details on the effect of the data bits on the transmission sequence refer to the configuration software manual (see the chapter "Monitoring devices").

Data bits non-safe AS-i slave

Data bit	D3	D2	D1	D0
In / Out			I-2	I-1/O-1

Activated input channel	Bit sequence D3-D0
I-1	XXX1
I-2	XX1X
Activated LED output	Bit sequence D3-D0
O-1	XXX1

X = random

Note: I-1 = NO contact; I-2 = NC contact

8 Addressing

When mounted the compact AS-i E-STOP safety module can be addressed via the M12 connector and the jumper cable, e.g. EVC011 using the addressing unit AC1154. The address of the safe AS-i slave is set to 0 at the factory. The address of the non-safe AS-i slave is set to 1A at the factory. For the safe AS-i slave assign a free address between 1 and 31. For the non-safe AS-i slave assign a free address between 1A and 31B.

If a slave with the extended addressing mode (AC2729) is used in combination with a master of the first generation (version 2.0), the parameter P3 must be 1 and the output bit D3 must be 0*. The output bit D3 and the parameter bit P3 must not be used. * default setting

If a slave with the extended addressing mode is used in combination with a master of the first generation (version 2.0), an address between 1A and 31A must be assigned to this slave.



Addressing via the M12 connector is only allowed when disconnected.

9 Operation

Check whether the unit operates correctly. Indication by LEDs on the PCB:

- LED green: voltage supply ok
- The red LED is lit: AS-i communication error, slave does not participate in the "normal" exchange of data, e.g. slave address 0
- LED red flashes: peripheral fault, e.g. sensor supply overloaded or shorted
- LED yellow: inputs switched
- LED alarm red: alarm output O-1 (non-safe)
(through the host system the alarm output LED can be set as a static or dynamic output)
- LED white: LED output O-1 (non-safe)



Overload and short circuit of the input supply are signalled to the AS-i master (version 2.1) via the "periphery fault" flag in the status register.

Accessories (optional)

E-STOP label in four languages (German, English, French, Italian); order no. E7003S.

9.1 Response times

The response time of the E-STOP safety module for a safety request is max. 10 ms.

Calculation of the total response time:

For the calculation of the response time of the complete system the response times of the other components also have to be added (mechanical contacts, safety monitor and external relays or contactors possibly connected to the safety monitor output).

Example:

The response time of the E-STOP safety module for a safety request is max. 10 ms. In addition the response time of the safety monitor (e.g. AC001S) has to be taken into account which is max. 40 ms including data transfer. The sum of the individual responses results in a total response time of max. 50 ms before application of the signal to AC012S until the safe outputs of the safety monitors switch. Here, the switching times of the external relays and contactors connected to the relay output of the safety monitor have not been taken into account.

10 Safety characteristics

Characteristics	Value
Safety integrity level	SIL 3
Category	cat. 4
Service life T	20 years
PFD _{avg}	$7.9 \cdot 10^{-6}$
PFH _D	$1.8 \cdot 10^{-10} / \text{h}$

- These calculations were made on the basis of an ambient temperature of 40 °C.
- The device meets the requirements of EN ISO 13849-1: 2015; PL e (category 4), SIL 3 (IEC 61508) and can be used in applications up to SIL 3 / PL e.
- The PFD / PFH values and MTTFd values of the other components, especially of the AS-i safety monitor, can be found in the corresponding documentation.

Explanation of the abbreviations:

SIL	Safety Integrity Level	Safety Integrity Level SIL 1-4 to IEC 61508. The higher the SIL the lower the probability that a safety function will fail.
PL	Performance Level	Capability of safety-related parts to perform a safety function at predictable conditions to fulfil the expected risk reduction.
PFD _{avg}	Probability of failure on demand	Probability of a dangerous failure.
PFH _D	Probability of Dangerous Failure per Hour	
T	Life time	Max. service life.

UK

11 Technical data

Safe AS-i slave

Electrical design	2 safe inputs / 1 non-safe LED output
Operating voltage	26.5 ... 31.6 V DC
Current consumption	< 50 mA
Inputs	
Wiring	DC PNP
Voltage supply	via AS-i
Voltage range	≥ 20 V DC
Short-circuit proof	yes
Input current high/low	4 mA
LED output	
Power via AS-i	yes
Short-circuit proof	no
Integrated Watchdog	yes
Max. current load output	10 mA
LED	red
AS-Interface / extended addressing mode possible	version 2.1 / no
AS-i profile	S-7.B.E
I/O configuration	7 [Hex]

ID code	B.E [Hex]
AS-i certificate	74601
Maximum number of safe AS-i slaves	31

Non-safe AS-i slave

Electrical design	2 inputs / 1 LED output
Operating voltage	26.5 ... 31.6 V DC
Current consumption	< 50 mA
Inputs	
Wiring	DC PNP
Voltage supply	via AS-i
Voltage range	≥ 20 V DC
Short-circuit proof	yes
Input current high/low	4 mA
LED output	
Power via AS-i	yes
Short-circuit proof	no
Integrated Watchdog	yes
Max. current load output	10 mA
LED	white
AS-Interface / extended addressing mode possible	version 2.1 / yes
AS-i profile	S-7.A.E
I/O configuration	7 [Hex]
ID code	A.E [Hex]
AS-i certificate	75101
Maximum number of non-safe AS-i slaves	62
Common data	
Operating temperature	-25...60 °C
Protection	IP 67
EMC	EN 61000-6-4; EN 62026-2
Housing materials	PC-GF20 (polycarbonate)

Housing dimensions	80 x 207 x 105 mm (HxWxD)
Connection	M12x1 connector

12 Scale drawing

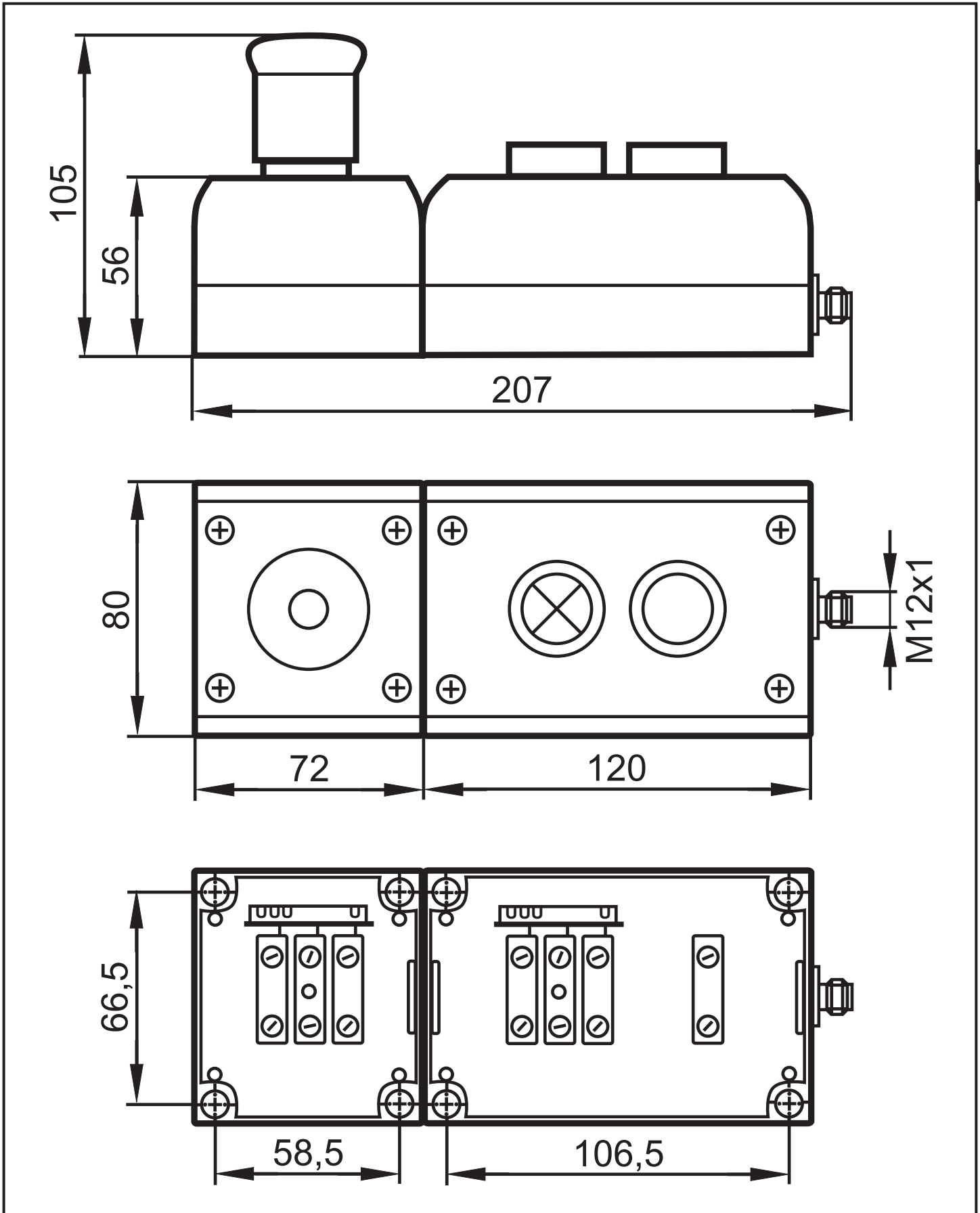

UK

13 Troubleshooting

The LEDs of the compact AS-i E-STOP safety module indicate faulty operating states (→ chapter 9 Operation).

14 Maintenance, repair and disposal

If used correctly no maintenance and repair measures are necessary.

Only the manufacturer is allowed to repair the unit.

After use dispose of the unit in an environmentally friendly way in accordance with the applicable national regulations.

15 Approvals/Certificates

- EC declaration of conformity
- AS-Interface
- TÜV Nord
- UL (cULus)

