

ifm electronic



Original operating instructions
AS-i safety monitor

AS interface
AC031S / AC032S

UK

7390834 / 01 09 / 2010

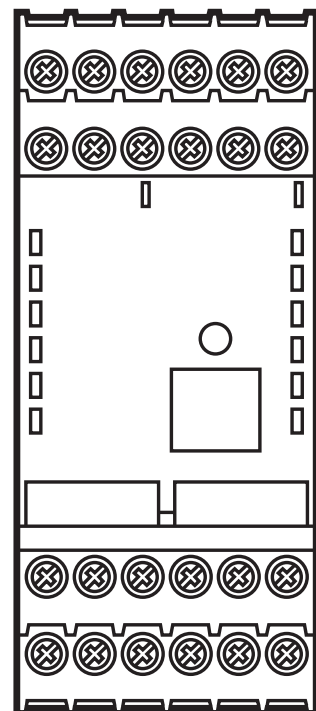

Contents

Safety instructions	3
Applications	4
Function and electrical connection	4
Operating and display elements	5
Meaning of the LED indicators in protective operation	6
Installation	8
Electrical connection.....	9
Addressing.....	9
Response times.....	9
Safety characteristics	10
Replacing a defective safe AS-i slave	11
Terminal connection of the AS-i safety monitor	12
Scale drawing	13
Technical data.....	14
Standards	16
Approvals/Certificates.....	16

Safety instructions

Follow the operating instructions.

Non-observance of the instructions, operation which is not in accordance with use as prescribed below, wrong installation or incorrect handling can affect the safety of operators and machinery.

For installation and prescribed use of the product the notes in the operating instructions must be carefully observed and the applicable technical standards relevant for the application have to be considered.

In case of non-observance of notes or standards, specially when tampering with and/or modifying the product, any liability is excluded.

The unit must be installed, connected and put into operation by a qualified electrician trained in safety technology.

After installation the system has to be subjected to a complete function check.

Disconnect the device externally before handling it. Also disconnect any independently supplied relay load circuits.

For installation the requirements according to EN 60204-1 must be observed.

In case of malfunction of the unit please contact the manufacturer. Tampering with the unit can seriously affect the safety of operators and machinery. This is not permitted and leads to an exclusion of liability and warranty.

Warning



Dangerous electrical voltage!

Can lead to electric shock and burns. Disconnect the system and the units from power before handling them.

Applications

The AS-i safety monitor is used in an AS-i bus system for monitoring of protective devices, e.g. e-stops. It is classified as safety category 4 according to EN 954-1, to EN ISO 13849-1 / PL e or according to IEC 61508 / SIL 3.

Important note



Depending on the safety components used the complete safety system might also be classified for a lower safety category.

Function and electrical connection

Please refer to all information in the description of the configuration software and the technical description of the unit. These documents provide all required instructions concerning installation, configuration, operation and maintenance of the AS-i safety monitor.

Important note

The products described herein are designed to be components of a safety-oriented machine or control system. A complete safety-related system normally includes sensors, evaluation units, signalling components and concepts for safe switch-off. It is the responsibility of each manufacturer of a machine or installation to ensure a correct functioning of the whole system. The manufacturer of the AS-i safety monitor, his subsidiaries and affiliates are not in a position to evaluate all of the characteristics of a given machine or product.

The manufacturer accepts no liability for any recommendation that may be implied or stated herein.

The warranty contained in the contract of sale is the sole warranty. Any statements contained herein do not create new warranties or modify existing ones.

The complete description of the configuration software and the technical description of the AS-i safety monitor must be taken into account!





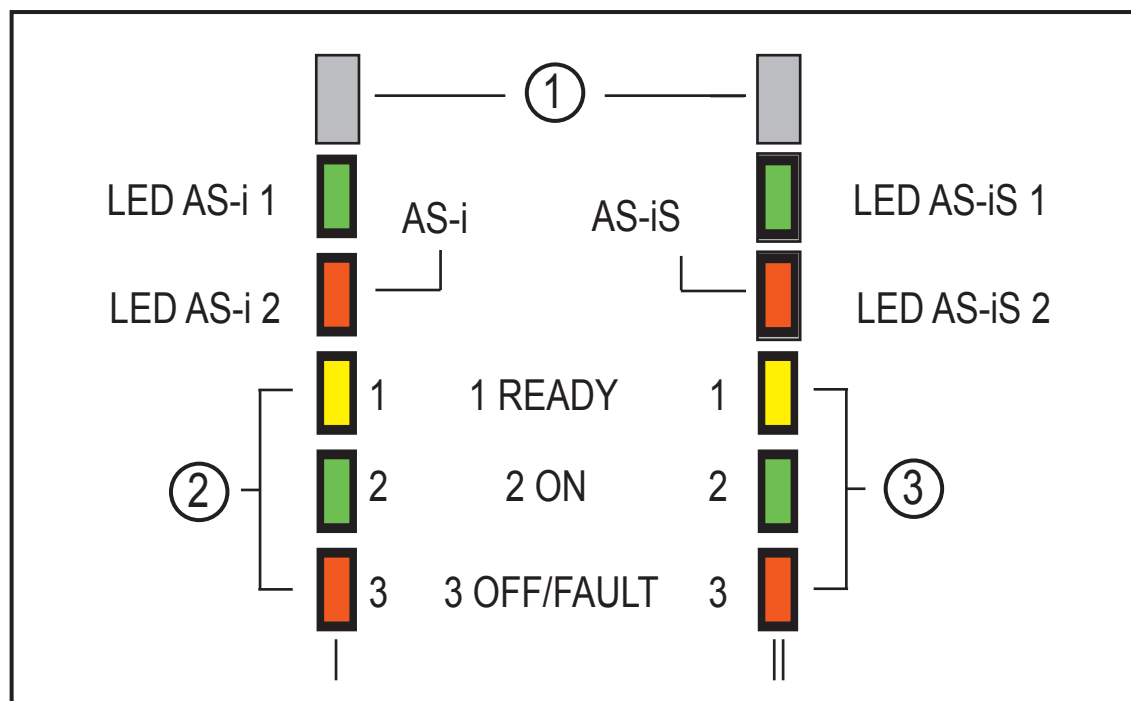











Operating and display elements

The LED indicators on the front side of the AS-i safety monitor provide information about the operating mode and the device state.



- 1: not used
- 2: channel (output circuit) 1
- 3: channel (output circuit) 2

Meaning of the LED indicators in protective operation

LED	Colour	Description	
AS-i 1		off	no supply
		green, continuous	AS-i supply present
AS-i 2		off	normal operation
		red, continuous	communication error
AS-iS 1 (safe AS-i output)		off	no supply
		green, continuous	AS-i supply present
AS-iS 2 (safe AS-i output)		off	normal operation
		red, continuous	communication error
1 READY (per output circuit)		off	—
		yellow, continuous	startup / restart disable active
		yellow, flashing	external test necessary / acknowledgement / switch-on delay active
2 ON (per output circuit)		off	contacts of the output switching element open
		green, continuous	contacts of the output switching element closed
		green, flashing	delay time runs in event of Stop Category 1
3 OFF/FAULT (per output circuit)		off	contacts of the output switching element closed
		red, continuous	contacts of the output switching element open
		red, flashing	error on the level of the monitored AS-i components

<p>1 READY 2 ON 3 OFF/FAULT (per output circuit)</p>		<p>yellow, green, red simultaneously flashing rapidly</p>	<p>internal device error, error message can be queried by means of ASIMON software</p>
--	--	---	--

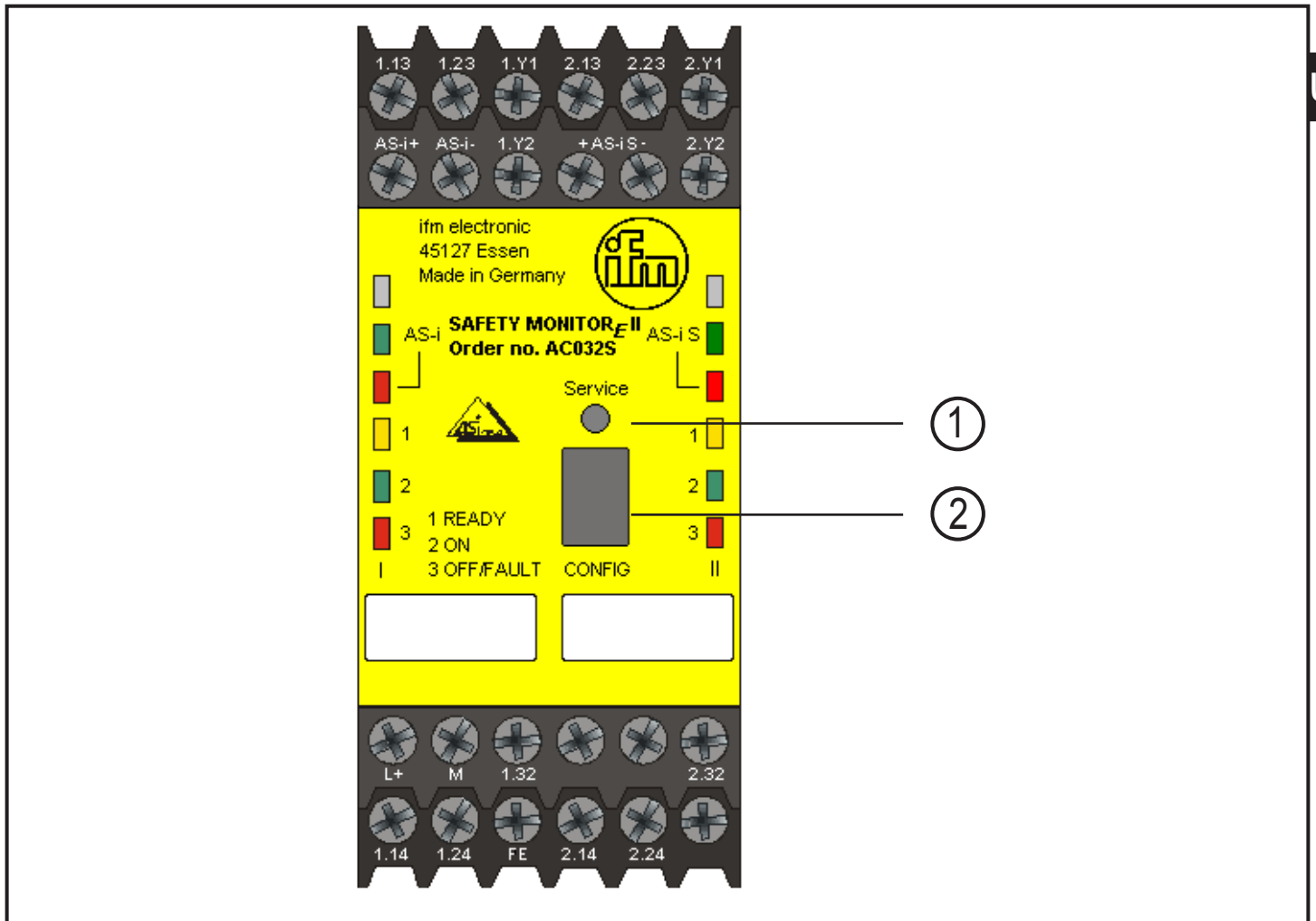

- 1: Service button
- 2: RJ45 socket CONFIG of the RS 232C configuration interface

The AS-i safety monitor is available in two versions which differ with regard to the functions provided by the operating software and the initial configuration.

Characteristics of the unit versions

		Functions "extended"	
		Output circuit 1	Output circuit 2
Number of output circuits: 1	Type 5 (AC031S)	relay	safe AS-i output
Number of output circuits: 2	Type 6 (AC032S)	relay	relay and safe AS-i output

Installation

The AS-i safety monitor is installed on 35 mm standard rails to DIN EN 50022 in the control cabinet. To install, position the device on the bottom edge of the standard rail and then snap it onto the upper edge.

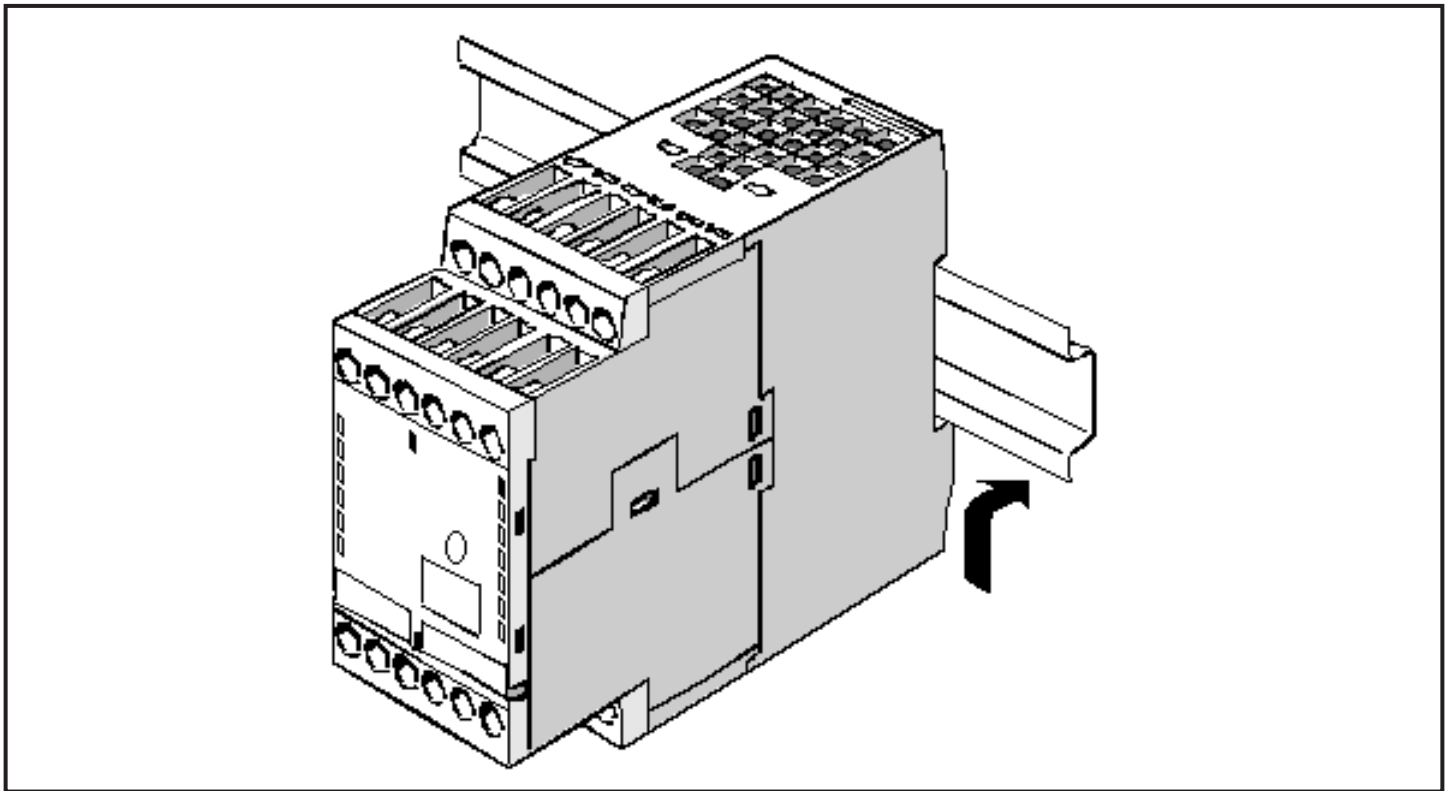

To avoid failures it is recommended to adhere to the operating temperature of the AS-i safety monitor for installation in control cabinets as specified in the technical data. In general it is recommended to adhere to a minimum distance of 10 mm between several safety monitors and to other control cabinet components.

Attention



Lay the supply, signal cables and also the AS-Interface cables separately from high voltage cables.

Use external relays or contactors externally connected to the safety monitor output with suitable protective circuitry!

Electrical connection

As soon as the supply voltage is present at the device, the internal system test begins. This operating status is indicated by the switching on of all LEDs installed in the device.

UK

Addressing

The AS-i safety monitor can only be addressed using the ASIMON software. Assign a free address between 1 and 31. No address allocation is possible using the addressing unit AC1154.

Response times

The system response time of the AS-i safety monitor for a safety request is max. 40 ms.

Calculation of the total response time:

For the calculation of the response time of the complete system the response times of the other components also have to be added (mechanical contacts, safe AS-i input/output modules and external relays or contactors possibly connected to the safety monitor output).

Safety characteristics

Characteristics	Value
Safety integrity level	SIL 3
Performance Level	PL e
Category	Cat. 4
MTTF _d	high
Mission time T	20 years
PFH	$9.9 \cdot 10^{-9}$
PFD	$7.2 \cdot 10^{-5}$

- The indicated PFD and PFH values refer to the maximum 12 months of powered operation.
- The unit can be used in applications up to SIL 3 / PL e.
- The PFD / PFH values and MTTF_d values of the other components, especially of the AS-i safety monitor, can be found in the corresponding documentation.

Explanation of the abbreviations:

SIL	Safety Integrity Level	Safety Integrity Level SIL 1-4 to IEC 61508. The higher the SIL the lower the probability that a safety function will fail.
PL	Performance Level	Capability of safety-related parts to perform a safety function at predictable conditions to fulfil the expected risk reduction.
PFD	Probability of a dangerous failure	
PFH	Probability of Dangerous Failure per Hour	
T	Life time	(= max. service life)
MTTF _d	Mean Time To Dangerous Failure	

Replacing a defective safe AS-i slave

If a safe AS-i slave is defective, it is possible to replace it without a PC and without reconfiguring the AS-i safety monitor by using the Service button on the AS-i safety monitor.

Attention



Actuation force for the Service button max. 1 N!

Note

When the Service button is pressed, the AS-i safety monitor switches from protective operation to configuration operation. The output circuits are therefore deactivated in all cases.

Pressing the Service button is acknowledged by a one-time, brief illumination of all device LEDs.

Proceed as follows:

1. Disconnect the defective AS-i slave from the AS-i line.
2. Press the Service button for approx. 1 second on all AS-i safety monitors which use the defective safe AS-i slave.
3. Connect the new safe AS-i slave to the AS-i line.
4. Press the Service button again for approx. 1 second on all AS-i safety monitors which use the replaced safe AS-i slave.

The first time the Service button is pressed, the monitor determines whether exactly one slave is missing. This is noted in the error memory of the AS-i safety monitor. The AS-i safety monitor switches to configuration operation. The second time the Service button is pressed, the code sequence of the new slave is read in and checked for correctness. If the code sequence is OK, the AS-i safety monitor returns to protective operation.

Attention



After replacing a defective safe slave, make sure to check the new slave for correct function.

Terminal connection of the AS-i safety monitor

Terminal	Signal / description
AS-i +/-	Connection to the AS-i bus
AS-iS+ AS-iS-	Safe AS-i output for actuator monitoring or connection to another AS-i network
L+	+24 V DC / supply voltage
M	GND / reference ground
FE	Functional earth
1.Y1	EDM 1 / input of external device monitoring circuit, output circuit 1
1.Y2	Start 1 / start input, output circuit 1
1.13	Output switching element 1, output circuit 1
1.14	Output switching element 1, output circuit 1
1.23	Output switching element 2, output circuit 1
1.24	Output switching element 2, output circuit 1
1.32	Safety ON / message output 1, output circuit 1
2.Y1	EDM 2 / input of external device monitoring circuit, output circuit 2
2.Y2	Start 2 / start input, output circuit 2
2.13	Output switching element 1, output circuit 2
2.14	Output switching element 1, output circuit 2
2.23	Output switching element 2, output circuit 2
2.24	Output switching element 2, output circuit 2
2.32	Safety ON / message output 2, output circuit 2

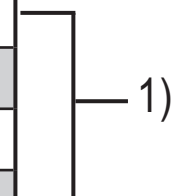

1) only type 6

Connection type 5 and type 6

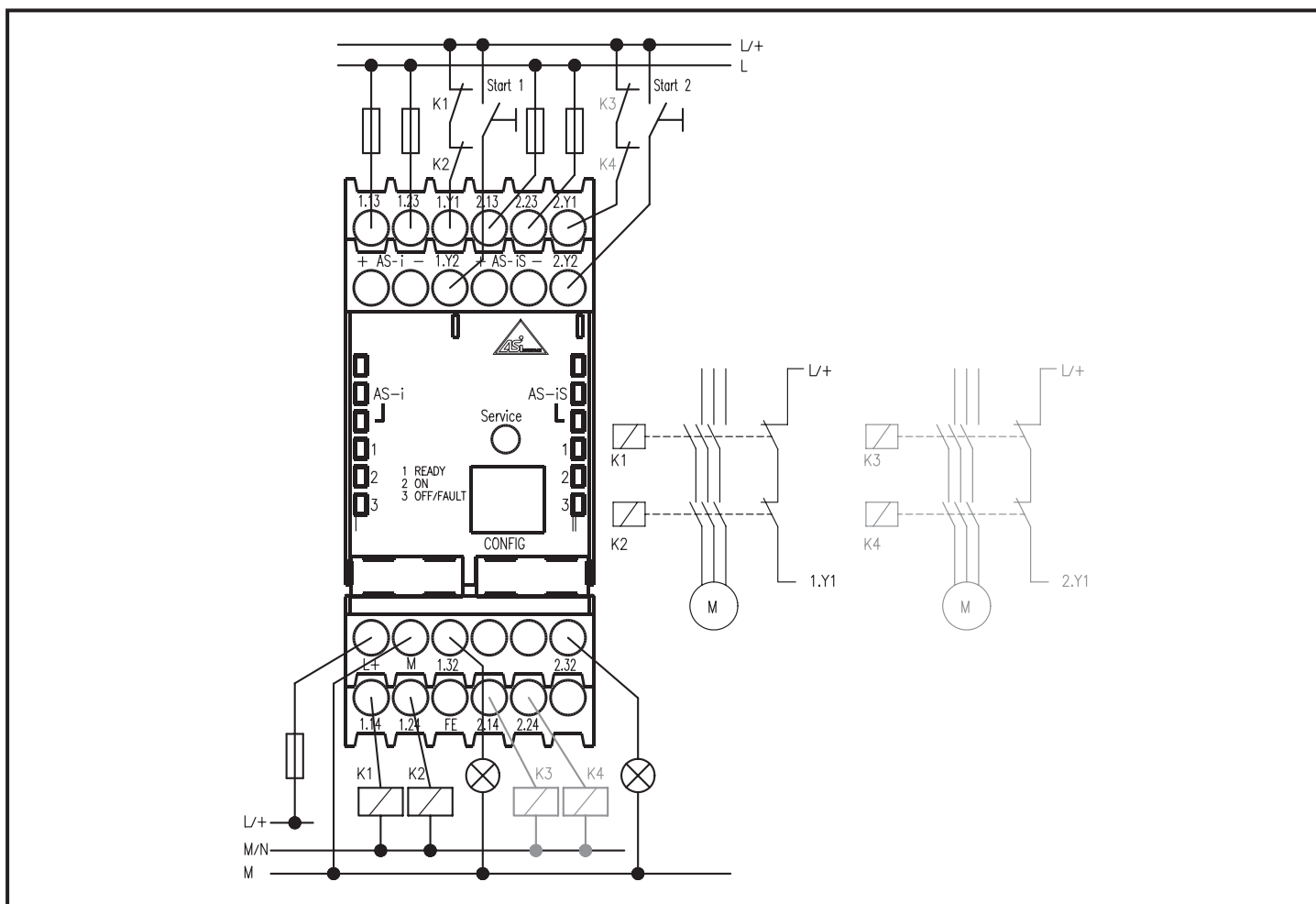

Scale drawing

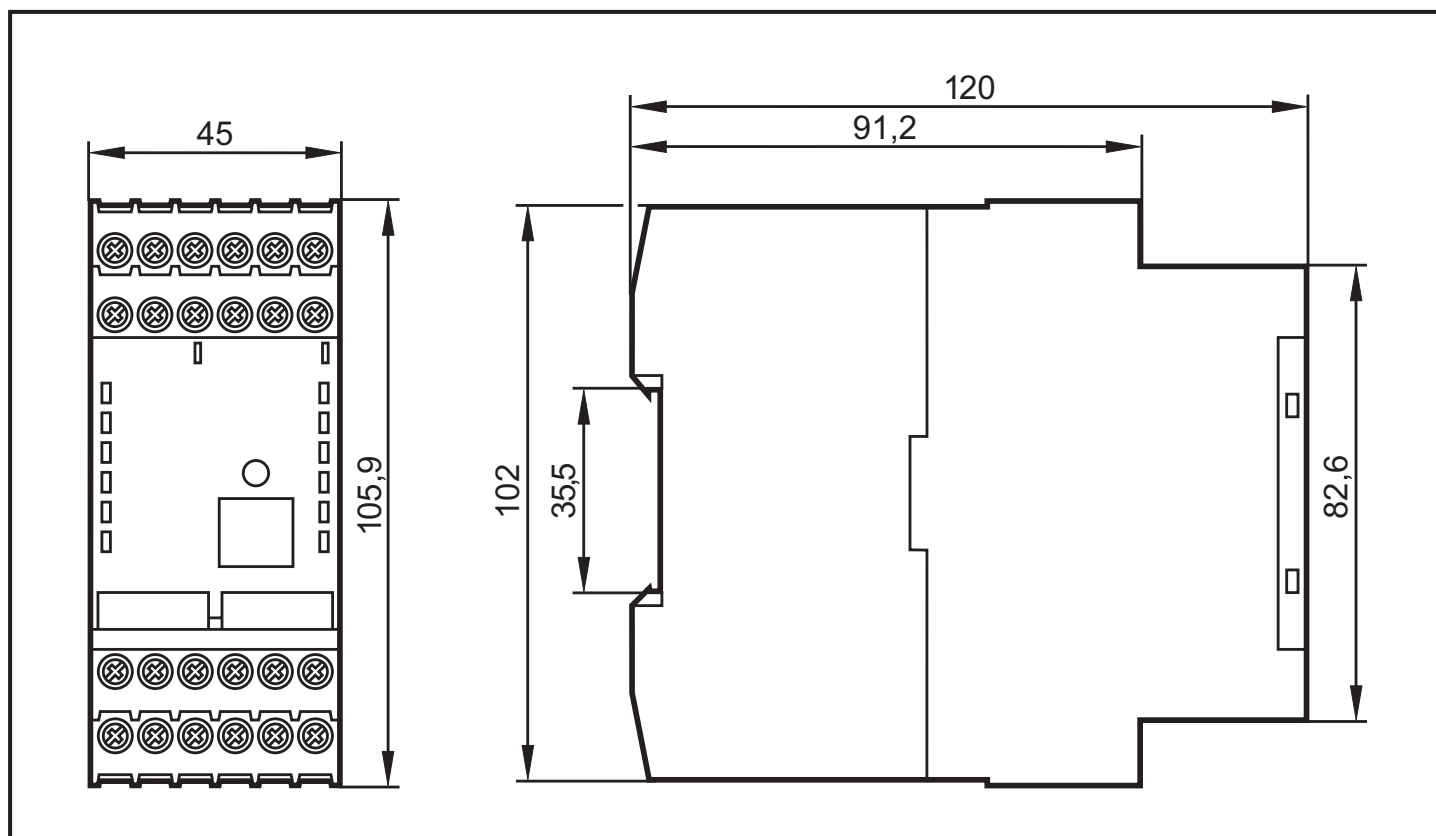

Technical data

Electrical data	
Operating voltage	24 V DC +/- 15%
Residual ripple	< 15%
Rated operating current	typ. 5: 200 mA typ. 6: 250 mA
Peak switch-on current ¹⁾	All types: 600 mA
Reaction time (safety-relevant)	< 40 ms
Power-on delay time	< 10 s
AS-i data	
AS-i profile	Monitor 7.F
AS-i voltage range	18.5...31.6 V
AS-i current consumption	< 45 mA
Configuration interface	
PK 232	9600 baud, no parity, 1 start bit, 1 stop bit, 8 data bits
Inputs and outputs	
"Start" input	Optical coupling input (high active), input current approx. 10 mA at 24 V DC
"External device monitoring circuit" input	Optical coupling input (high active), input current approx. 10 mA at 24 V DC
Message output "Safety ON" ²⁾	PNP transistor output, 200 mA, short circuit and reverse polarity protection
Safety output	Potential-free make contacts, max. contact load: 1 A DC-13 at 24 V DC 3 A AC-15 at 230 V AC
Safeguarding	External with max. 4 A slow blow
Overvoltage category	3, for rated operating voltage 300 V AC to VDE 0110 part 1
1) Simultaneous energising of all relays, the current for the feedback outputs is not taken into consideration	
2) The "Safety ON" message output is not relevant to safety!	

Environmental data	
Operating temperature	-20...60 °C
Storage temperature	-30...70 °C
Protection rating	IP20 (only suitable for use in electrical operating rooms / control cabinet with minimum protection IP54)
Distance between 2 AS-i safety monitors	10 mm
Mechanical data	
Dimensions (W x H x D)	45 mm x 105 mm x 120 mm
Housing material	polyamide PA66, black
Weight	typ. 5: approx. 420 g; typ. 6: approx. 450 g
Fixing	Snap-on mounting on DIN rail to EN 50022

UK

Standards

The following standards and directives have been applied:

- MLR 2006/42/EC
- EN ISO13849-1: 2008
- IEC 61508 parts 1-7: 2000
- EN 954-1: 1996
- EN 62061:2005
- EN 50295: 1999
- EN 61496-1: 2008
- EN 50178:1997
- EN60204-1: 2006
- EN 60947-5-1: 2004
- NFPA 79:2007
- UL 508

In the UL scope:

The safety monitor was only assessed for UL508. The UL assessment does not include functional safety.

Approvals/Certificates

- EC declaration of conformity
- TÜV Rheinland
- UL (cULus) see www.ifm.com