

Original operating instructions

**Fail-safe SmartPLC
with Profibus interface
AC412S**

UK

80283445/00 03/2019

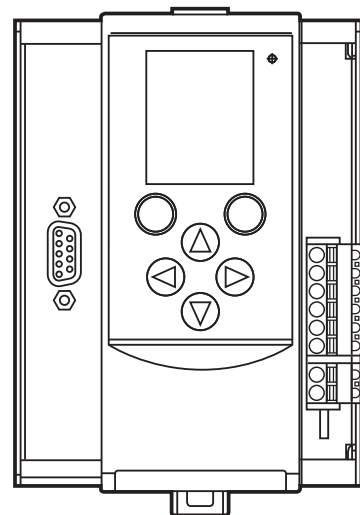

Contents

1	Preliminary note.....	4
1.1	Notes on this document.....	4
1.2	Symbols used.....	4
2	Safety instructions.....	4
2.1	General.....	4
3	Items supplied.....	5
4	Functions and features.....	6
4.1	Electrical voltage supply.....	6
4.2	Configuration interface.....	6
4.3	AS-i interface.....	6
4.4	Local safe inputs and outputs.....	6
4.5	Fieldbus interface.....	7
5	Installation.....	7
6	Operating, connection and display elements.....	8
6.1	Operating and connection elements.....	8
6.2	LED indicators.....	9
6.2.1	Device LED H1.....	9
7	Electrical connection.....	9
7.1	Wiring.....	10
7.2	Connect the supply voltage.....	10
7.2.1	Standard configuration: 24 V power supply and AS-i power supply/ supplies.....	10
7.3	Connect sensors / actuators.....	11
8	Operation.....	12
8.1	Notes on the EMC-compliant operation.....	12
8.2	Settings.....	13
8.2.1	Language selection.....	13
8.3	Navigation.....	14
8.3.1	Navigation elements.....	14
8.3.2	Pictograms and main navigation.....	15
8.3.3	OSC (Online Support Center).....	16
9	Diagnostics.....	17

10 Maintenance, repair and disposal.....	17
11 Approvals / tests.....	17
12 Additional documents.....	17
13 Technical data	18
13.1 Safety classification	19
14 Scale drawing	20

1 Preliminary note

1.1 Notes on this document

This document applies to devices of the type



"Fail-safe SmartPLC with Profibus interface" (art. no.: AC412S).

It is part of the device and contains information about the correct handling of the product.

This document is intended for qualified electricians. These specialists are people who are qualified by their training and their experience to see and to avoid possible hazards that may be caused during operation of the device. Installation and set-up must be carried out by staff qualified in functional safety.

- ▶ Read this document before using the device.
- ▶ Keep this document during the service life of the device.

1.2 Symbols used

- ▶ Instructions
- > Reaction, result
- [...] Designation of keys, buttons or indications
- Cross-reference
-  Important note
Non-compliance may result in malfunction or interference.
-  Information
Supplementary note

2 Safety instructions

2.1 General

- ▶ Observe these operating instructions.
- ▶ Adhere to the warning notes on the product.
- In case of non-observance of notes or standards, especially when tampering with and/or modifying the unit, any liability and warranty is excluded.
- The safe operation of the device is only ensured when the specified requirements are complied with.
- The applicable technical standards for the corresponding application must be complied with.
- For installation the requirements according to EN 60204 must be observed.

- In case of malfunction of the device contact the manufacturer. Tampering with the unit is not allowed.
- Do not insert any objects into the device.
- Prevent metal foreign bodies from penetrating.
- After installation of the system perform a complete function check.
- Only use the unit under the specified operating conditions (→ Technical data). In case of special operating conditions please contact the manufacturer. Use of the unit in the vicinity of chemical and biological media as well as ionising radiation is not permitted.
- In case of any questions please contact the safety authorities in your own country.

 WARNING

In case of improper handling of the product, the safety and physical integrity of persons and machinery cannot be guaranteed.

Death or serious irreversible injuries may result.

- ▶ Note all remarks on installation and handling given in these instructions.
- ▶ The device must only be used under the specified operating conditions and in accordance with use as prescribed below.

3 Items supplied

- 1 fail-safe SmartPLC AC412S
- 3 Combicon connection terminals
- 1 original operating instructions AC412S
- 1 EU declaration of conformity
- Service address list with ifm contacts

If one of the above-mentioned components is missing or damaged, please contact one of the ifm branch offices.



Device manual and programming manual are not supplied. These are available at www.ifm.com.

4 Functions and features

The fail-safe SmartPLC integrates two AS-i masters, a safe PLC, a non-safe PLC, a WEB server and a Profibus interface.

- It controls the exchange of data to the sensor / actuator level.
- It can be used as a safe and a non-safe controller (PLC).
- It communicates with the higher-level control level via Profibus.
- It visualises sensor / actuator data on the integrated WEB server.
- It allows device configuration via the WEB server.

4.1 Electrical voltage supply

- Device supply from 24 V (AUX)

4.2 Configuration interface

- RJ45, twisted pair (10 Mbps and 100 Mbps)
- TCP/IP - Transport Control Protocol / Internet Protocol
- UDP/IP - User Datagram Protocol
- EtherCAT (master)
- Modbus TCP (master/slave)
- 3S network-global variables
- HTTP server
- CODESYS programming interface
- Secure network variables
- OPC UA
- CODESYS Web visualisation

4.3 AS-i interface

- 2 AS-i masters
- AS-i Power24 compatible
- Ground-fault detection

4.4 Local safe inputs and outputs

In the following they are called Safe-IO.

- 8 connection terminals for

- up to 4 safe inputs according to SIL3 / PL e / category 4
- up to 8 non-safe inputs



Use safe inputs always with two channels.

- 4 connection terminals for
 - up to 2 safe semiconductor outputs according to SIL3 / PL e / category 4
 - up to 4 non-safe outputs

4.5 Fieldbus interface

- Profibus DP (DPV0 / DPV1) 9.6 kbaud...12 Mbaud

5 Installation

The device must only be installed, connected and put into operation by a qualified electrician as the safe function of the device and machinery is only guaranteed when installation is correctly carried out.

The installation and connection must comply with the applicable national and international standards. Responsibility lies with the person installing the unit.

- ▶ Fix the device onto a 35 mm raised rail.
- ▶ Vertical installation (upright).
- ▶ Adhere to a minimum distance of 30 mm between the ventilation holes (perforated sheet) and other parts.
- ▶ Maximum operating altitude: 2000 m above sea level
- ▶ The protection rating of the device is IP 20. The installation must take place in a control cabinet with at least IP 54 protection.
- ▶ Lay the cables in a cable duct.
- ▶ Keep the installation space of the device free from electrically-conductive particles.



Ensure a condensation-free environment. Avoid excessive dust, vibration and shock. The air circulation through the vents must not be impeded.

Avoid installation in direct vicinity of frequency inverters or other interfering sources.

6 Operating, connection and display elements

6.1 Operating and connection elements

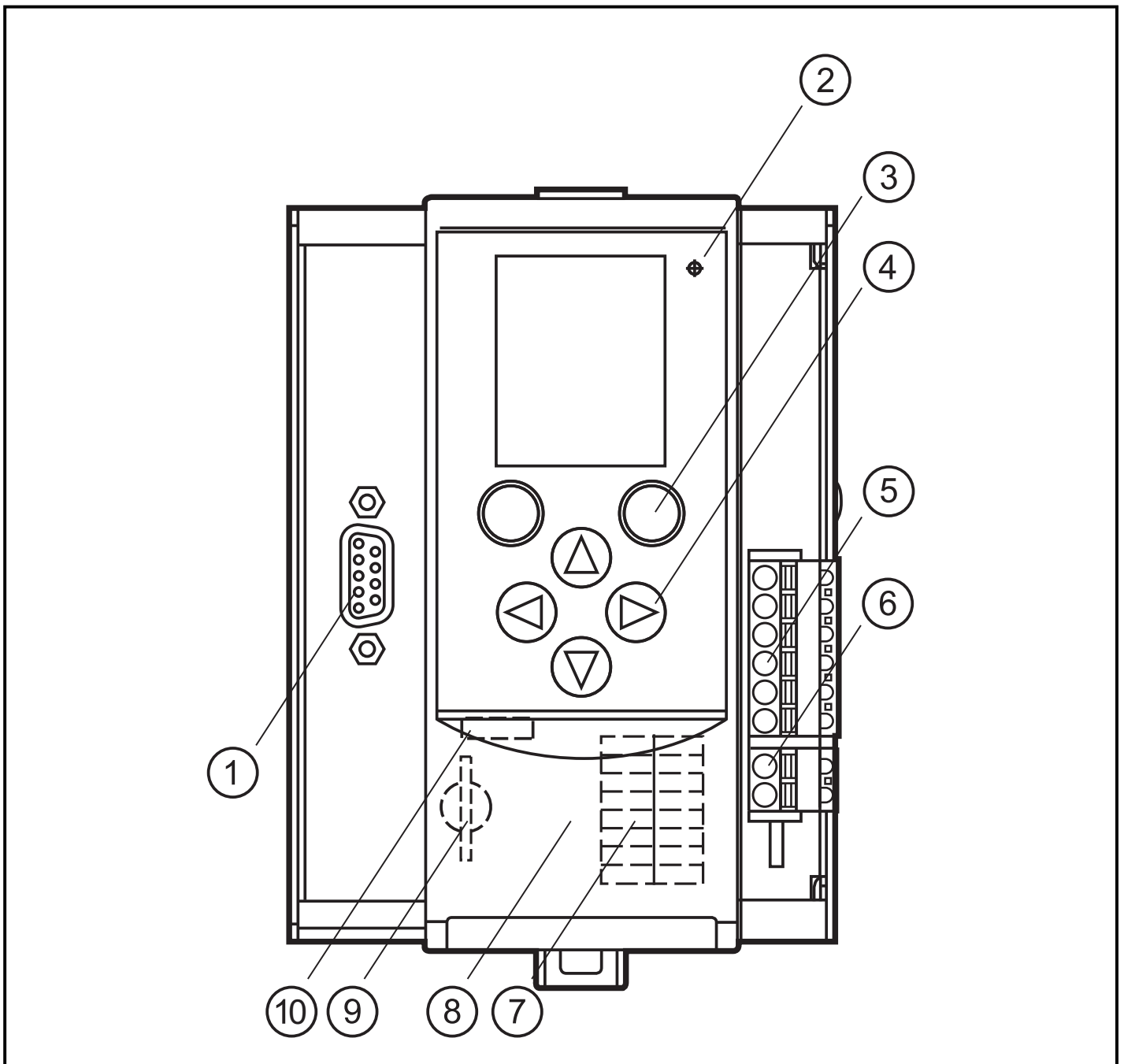

- 1: Profibus interface (D-Sub 9) X6
- 2: Device LED H1 green / yellow / red
- 3: Softkeys
- 4: Navigation buttons
- 5: AS-i bus and FE connection X1
- 6: 24 V device voltage supply X2
- 7: Connection for 24 V Safe-IO voltage supply and local inputs/outputs X4
- 8: Front flap
- 9: Slot for SD card
- 10: Configuration interface X3 (RJ45)

6.2 LED indicators

6.2.1 Device LED H1

The LED on the front panel signals the state of the device and the connected systems.

LED status	Description
Green LED lit:	<ul style="list-style-type: none">> Device has been started.> There is no warning message.> There is no error message
Yellow LED flashes slowly (0.5 Hz):	<ul style="list-style-type: none">> There is a warning message.> There is no error message.
Red LED flashes quickly (2 Hz):	<ul style="list-style-type: none">> There is an error message.

UK

7 Electrical connection



The unit must be connected by a qualified electrician.

- ▶ Disconnect the plant from the mains supply before installation.
- ▶ Observe the national and international regulations for the installation of electrical equipment.
- ▶ Connect the device as indicated on the terminals.
- ▶ Ensure an electrical connection between the fail-safe SmartPLC AC412S (terminal X1, pin 5 FE) and the ground of the installation.

7.1 Wiring

Terminal X1	Pin	Description
AS-i 2 +	1	AS-i + for AS-i line 2
AS-i 2 -	2	AS-i - for AS-i line 2
AS-i 1 +	3	AS-i + for AS-i line 1
AS-i 1 -	4	AS-i - for AS-i line 1
FE	5	Functional earth
	6	not used

Terminal X2	Pin	Description
24 V	1	+24 V device supply
GND	2	GND

Terminal X4	Pin	Description
	1...8	IN1...8
	9...12	OUT1...4
	13,14	GND
	15,16	+24 V power supply Safe-IO module

A fixed terminal assignment is mandatory for the safe inputs (IN 1...8) → Device manual → Installation → Connect devices to a local I/O interface.

Socket X3	Configuration interface
Socket X6	Profibus interface

7.2 Connect the supply voltage

7.2.1 Standard configuration: 24 V power supply and AS-i power supply/ supplies

- ▶ Connect the supply voltage inputs of the device to the power supply intended for this purpose.

AS-i bus 1

Connect the pins AS-i 1+ and AS-i 1- of terminal X1 to the AS-i power supply (e.g. AC1236) of the first AS-i bus.

AS-i bus 2

Connect the pins AS-i 2+ and AS-i 2- of terminal X1 to the AS-i power supply (e.g. AC1236) of the second AS-i bus.

24V device supply

Connect the pins 24 V and 0 V of terminal X2 to a 24 V DC power supply (18...32 V SELV/PELV)

24 V Safe-IO power supply

Connect the pins 24 V and GND of terminal X4 to a 24 V DC power supply (18...32 V SELV/PELV)

- ▶ Ensure a low-resistance connection of the symmetry point of the device (terminal X1, pin 5 FE) to the ground of the installation.
- ▶ For the 24 V power supply (device, Safe-IO), select a power supply which supplies an output current of at least 3 A.
- ▶ Power must be applied **simultaneously** to the Safe-IO module and to the device.
- ▶ The cable length of the DC supply between power supply and AC412S is to be limited to max. 3 m.

The power supplies used must meet the standard DIN EN 60950-1 for SELV/PELV.

7.3 Connect sensors / actuators

The connection of sensors or actuators to all local (safe) inputs and outputs takes place via terminal X4.

- ▶ Connect the switching signals of sensors to the pins IN1...IN8 of terminal X4.
- ▶ Connect actuators to the pins OUT1...OUT4 of terminal X4.
- ▶ When external sensors / actuators are connected, their supply voltage and/or reference potential of terminal X4 (Safe-IO module supply) must be tapped.
- ▶ When external sensors are connected, observe the max. permitted supply voltage of the sensor and select the Safe-IO module supply accordingly.
- ▶ The signal cable length for external devices (sensors, actuators) is to be limited to max. 10 m.

- ▶ Do not exceed the maximum output current of 0.5 A per output
- ▶ Do not exceed a switching frequency of 25 Hz when connecting the inductive loads (DC-13).

8 Operation

8.1 Notes on the EMC-compliant operation

- ▶ Use voltage supplies for the device that are not simultaneously used for the supply of known interfering sources (e.g. large inductive loads, motor starters, frequency converters, etc.).
- ▶ If the switching outputs of the device are used to control inductive loads (relays, contactors etc.), additional means of suppression have to be provided directly on those loads.
- ▶ Lay the cables of the digital inputs and outputs to be connected via the front connector in separated cable ducts. There should be no other cables in these ducts that are control or supply cables of known interfering sources.



This is a class A product which is intended for use in industrial applications. The unit may cause radio interference in domestic areas. In this case it can be necessary for the user to take appropriate measures.

8.2 Settings



During operation the display is switched off after 10 minutes without operation.

- ▶ Activate the display by pressing any desired button.

8.2.1 Language selection

- ▶ Change the user language of the device by pressing the ▶ button and the ▲ button or ▼ button simultaneously.

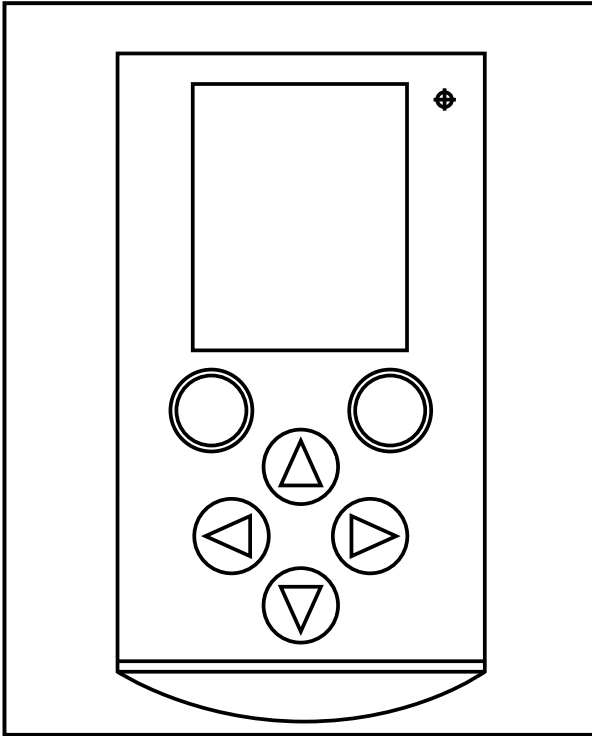

8.3 Navigation

8.3.1 Navigation elements

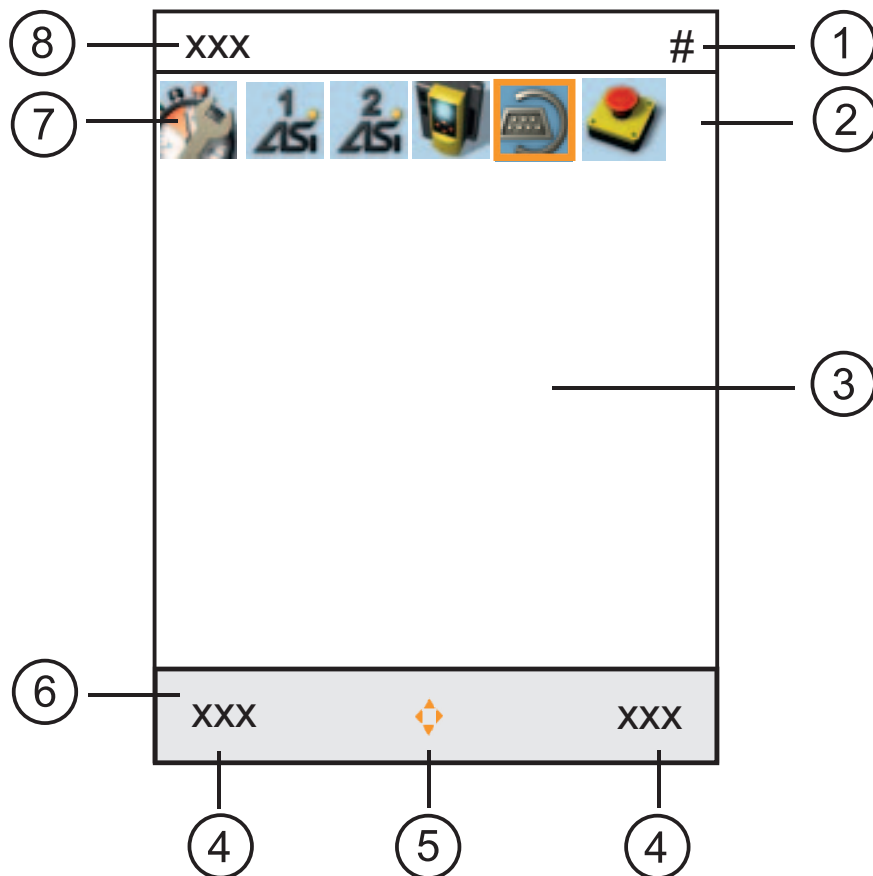

- 1: User level
- 2: Selection
- 3: Operating area
- 4: Softkey labelling (e.g. menu, OSC)
- 5: Navigation compass
- 6: Navigation status bar
- 7: Main navigation bar
- 8: Info bar

8.3.2 Pictograms and main navigation



Quick set-up (summary of the menu points required for a basic configuration)

- Config all
 - Projection adaptation for AS-i master 1 and AS-i master 2
- Operating mode
 - Selection of the operating modes for
 - AS-i master 1,
 - AS-i master 2,
 - Control of the outputs (gateway, manual, PLC)
- QR code
- Fieldbus Profibus
 - Display / modify the parameters of the Profibus interface
 - IP address
 - Subnet mask
 - Gateway address
- Configuration interface
 - Display / modify the parameters of the Ethernet configuration interface
 - DHCP
 - IP address
 - Subnet mask
 - Gateway address
- Addressing AS-i 1
 - Slave overview AS-i line 1 (with the option to change AS-i addresses)
- Addressing AS-i 2
 - Slave overview AS-i line 2 (with the option to change AS-i addresses)



AS-i 1

- AS-i master settings
- AS-i diagnostics
- AS-i slaves



AS-i 2

- AS-i master settings
- AS-i diagnostics
- AS-i slaves



System

- PLC
 - Information
 - Settings
 - Diagnostics
- Information
- Settings
- Diagnostics



Interfaces

- Settings and information of the configuration interface
- Settings and information of the Profibus interface



Safety

- Settings, information and diagnostics of the safe controller



Safety

- Safety functions not available



Further details → device manual

8.3.3 OSC (Online Support Center)

It is accessed via the softkey [OSC] on the start screen. Events, warning and error messages with a time stamp are displayed in plain text.

- Current version
- History

9 Diagnostics

Any information, warning or error messages are indicated in the display on the device. The pictogram of the function unit concerned is superposed by an information, warning or error symbol. If for one function unit a warning and an error message exist at the same time, only the error symbol is displayed.



Warning message



Information message



Error message



All messages are displayed in plain text in the Online Support Center (OSC).

10 Maintenance, repair and disposal

- ▶ Replace the buffer battery of the real-time clock as required, type CR2032.
- ▶ Dispose of the device in accordance with the national environmental regulations.

11 Approvals / tests

- EMC
- Functional safety / TÜV-Rheinland
- AS-Interface / AS-i Safety at Work
- UL (cULus)
- Profibus

12 Additional documents

Data sheets, device manual, programming manual and registration documents

→ www.ifm.com

13 Technical data

AC412S	
Use as an AS-i Profibus gateway with safe preprocessing 4 safe local inputs (two-channel) and 2 safe local semiconductor outputs	
Electrical data	
Number of AS-i masters	2
Operating voltage [V]	18...32 DC (AUX)
Current consumption from 24 V DC and AS-i [mA]	< 750 (24 V) / < 10 from AS-i 1 / < 10 from AS-i 2
Electrical separation	yes
Inputs	
Circuits	DC PNP (type 2 to IEC 61131-2)
Sensor supply	to SELV/PELV
Voltage range [V]	24 DC (18...32 DC)
Input current [mA]	7
Outputs	
Output function	Transistor PNP (according to IEC 61131-2)
Voltage range [V]	24 DC (18...32 DC)
External supply	to SELV/PELV
Max. current load per output [mA]	500
Max. inductance [mH]	400
Max. switching frequency [Hz]	25
Utilisation category	DC-13 (according to IEC 60947-5-1)
Electrically isolated	yes
Short-circuit protection	yes
Interfaces	
Programming interface	Ethernet
Data interface	Profibus DP (DPV0 + DPV1), max. 12 Mbaud, EN50170
Environmental conditions	
Ambient temperature [°C]	0...50, for UL application: max. 45
Storage temperature [°C]	-20...70
Max. perm. relative air humidity [%]	95, non-condensing
Height above sea level [m]	< 2000

Protection	IP 20
AS-i classification	
AS-i version	3.0
AS-i profile	M4
AS-i certificate	125301
Mechanical data	
Housing materials	Aluminium powder-coated; Steel sheet galvanised; Makrolon
Displays / operating elements	
Display	Full graphic LCD display
LED function display	1 x combined LED (red / green)

UK

13.1 Safety classification

Meets the requirements of EN ISO 13849-1: 2015 category 4 PL e IEC 61508: 2010 SIL 3	
Mission Time (TM)	20 years
Safety-related reliability PFHd [1/h]	$1.21 \cdot 10^{-08}$
PFD	$1.04 \cdot 10^{-04}$

14 Scale drawing

