

ifm electronic



Operating Instructions

AS interface

ATEX ClassicLine

Analogue module

AC522A

UK

7390946/00 08/2012



Contents

1 Safety instructions	3
2 Functions and features	3
3 Operating and display elements	4
4 Assembly	5
5 Addressing	10
5.1 Addressing with the AC1154 addressing unit	10
6 Current measurement.....	10
7 Parameter setting of the analogue module.....	11
8 Electrical connection.....	11
9 Operation.....	12
10 Measuring range of the module.....	12
11 Technical data	13



Observe the instructions for the safe use in hazardous areas: → Operating instructions (Ex protection related part) for AS-i modules according to EU directive 94/9/EC annex VIII (ATEX) group II, equipment category 3D.

If no operating instructions (Ex protection related part) or EC declaration of conformity is supplied with this product in the language of the EU user country, these can be requested from your dealer (see delivery note) or manufacturer (see cover sheet / back).

1 Safety instructions

- Please read the product description prior to installing the unit. Ensure that the product is suitable for your application without any restrictions.
- The unit conforms to the relevant regulations and EU directives.
- Improper use or non-intended use may lead to malfunctions of the unit or to unwanted effects in your application.
- That is why installation, electrical connection, set-up, operation and maintenance of the unit must only be carried out by qualified personnel authorised by the machine operator.

UK

2 Functions and features

The slave converts analogue input signals and transfers them to the AS-i master via the AS-Interface. The AS-i module operates as a slave with bidirectional data transfer in the AS-i network.

The data transfer to the host is asynchronous according to the AS-i profile S-7.3.D and the AS-i specification 3.0, downward compatible.

- maximum number of modules per master: 31
- current measurement 4...20 mA
- time for converting the measured values in the slave
 - for one channel: 60 ms
 - for two channels: 120 ms

When the actuators are supplied from AS-i the load must not exceed a maximum of 200 mA. There is an electrical connection between the sensor and AS-i.

3 Operating and display elements

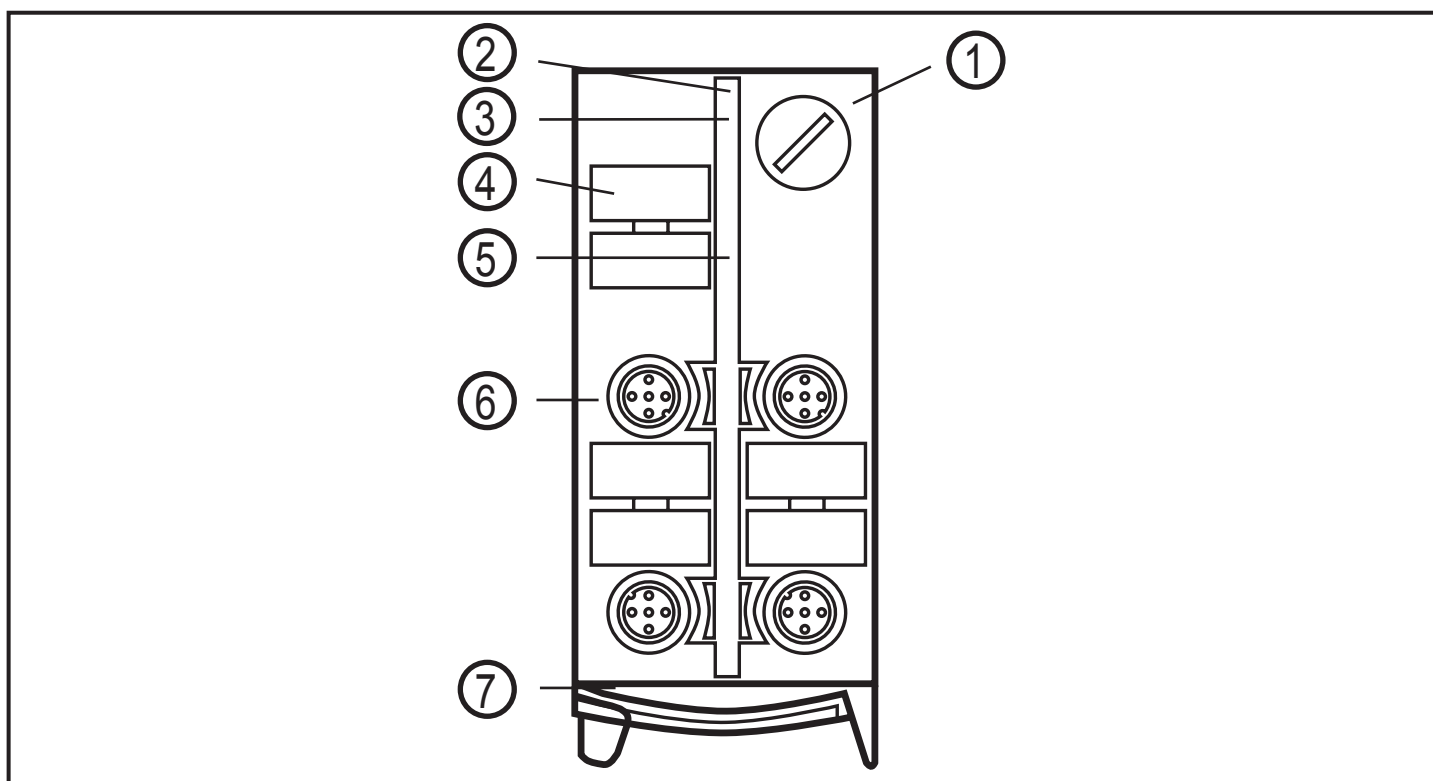

1. addressing interface
2. LED PWR
3. LED FAULT
4. labels
5. LED 1
6. 2 M12 sockets
7. earthing lead

Scale drawing

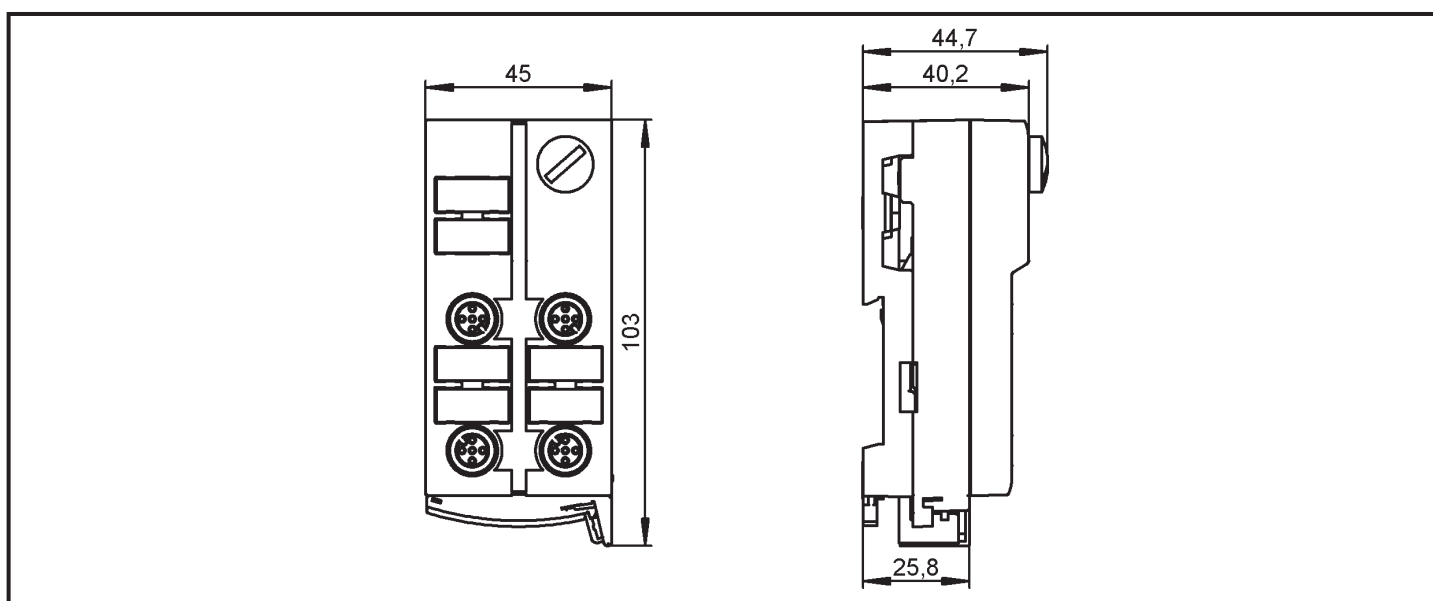

4 Assembly

1

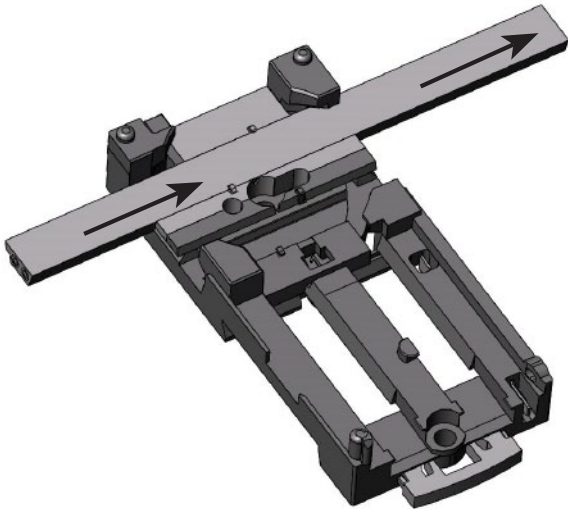

Orientation of the flat cable on delivery

Carefully place the yellow flat cable into the profile slot.

UK

2

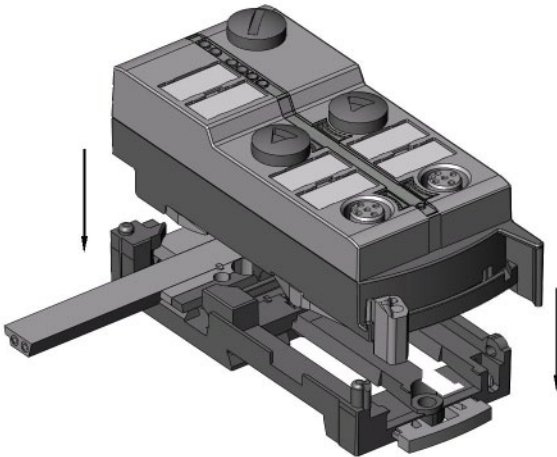

Mount the upper part.

3



Lock the unit.

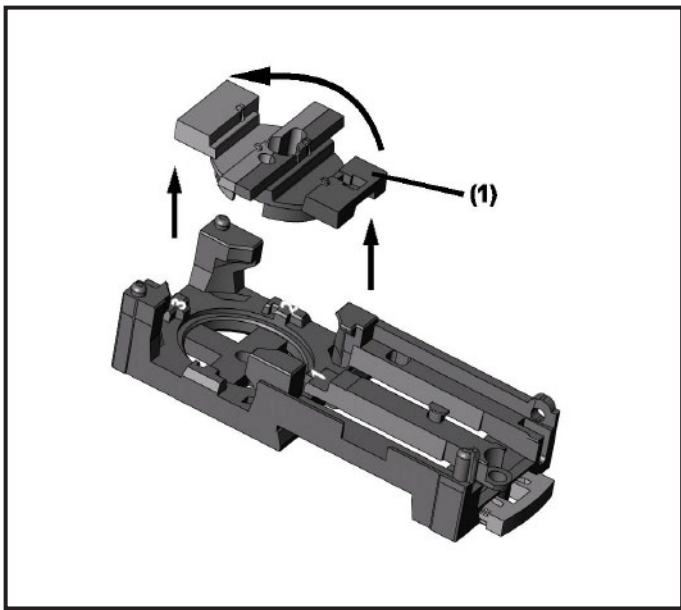

With the supplied lower part the flat cable can be aligned in three directions.

For the requested direction place the flat cable guide (1) accordingly.

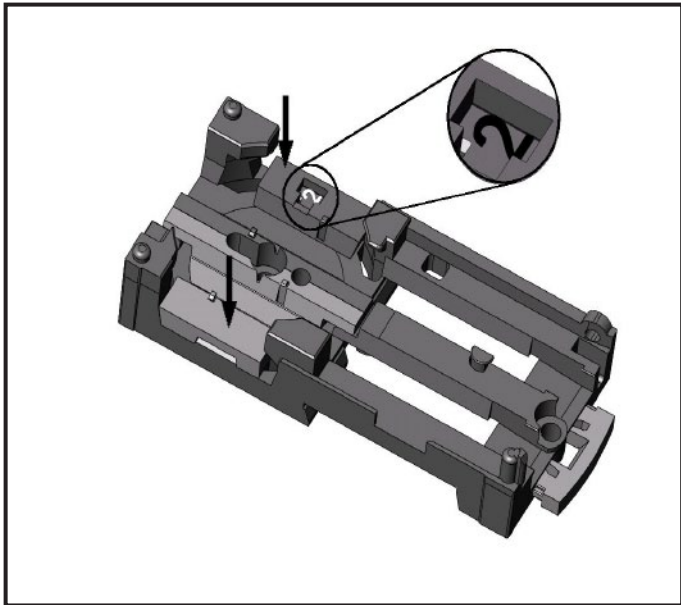

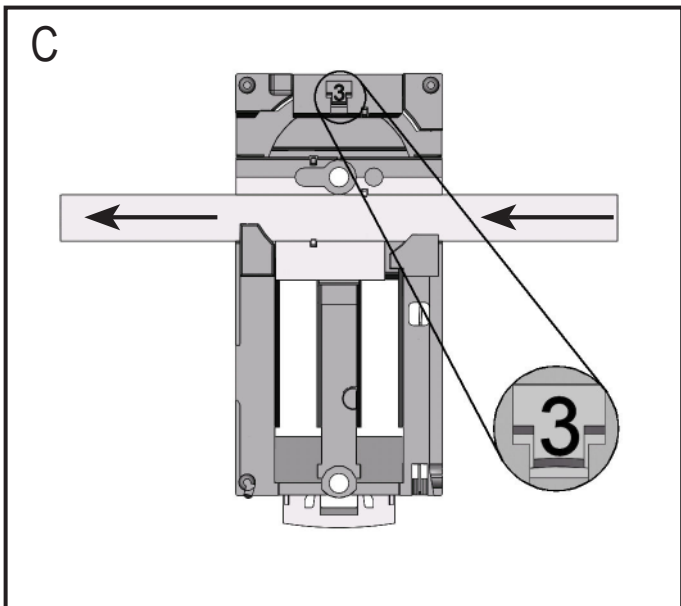
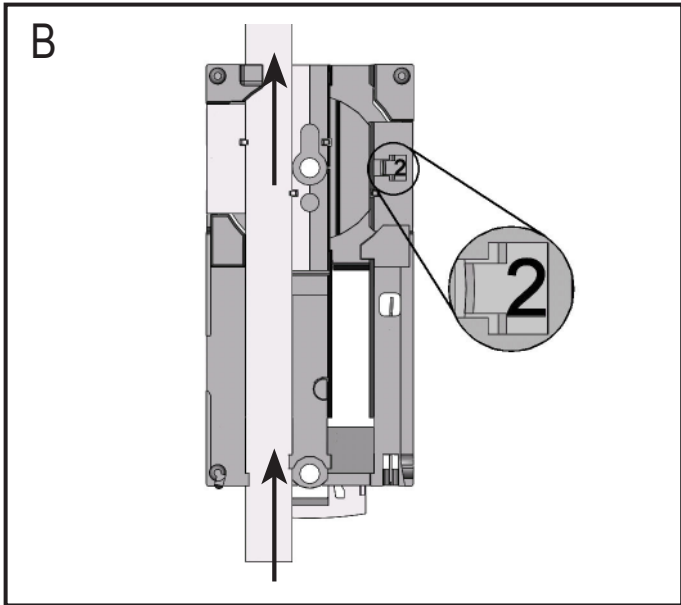
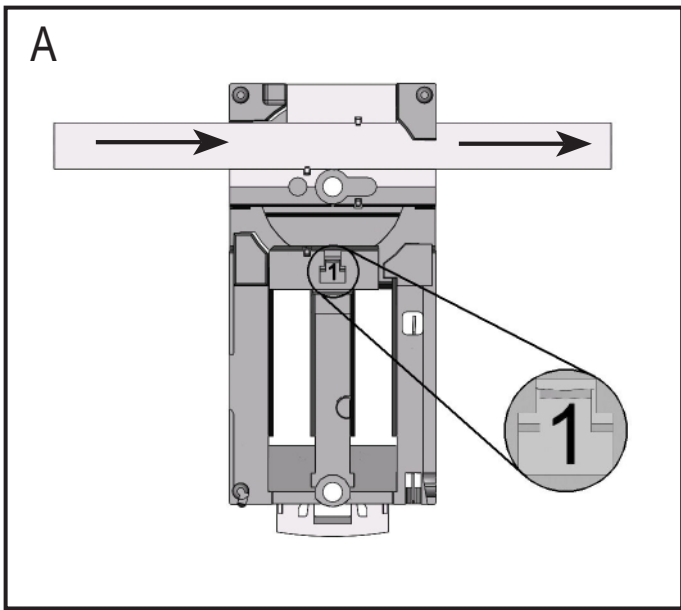

Settings at the lower part

Select the position 1, 2 or 3 depending on the requested flat cable alignment (→).

A = Factory setting

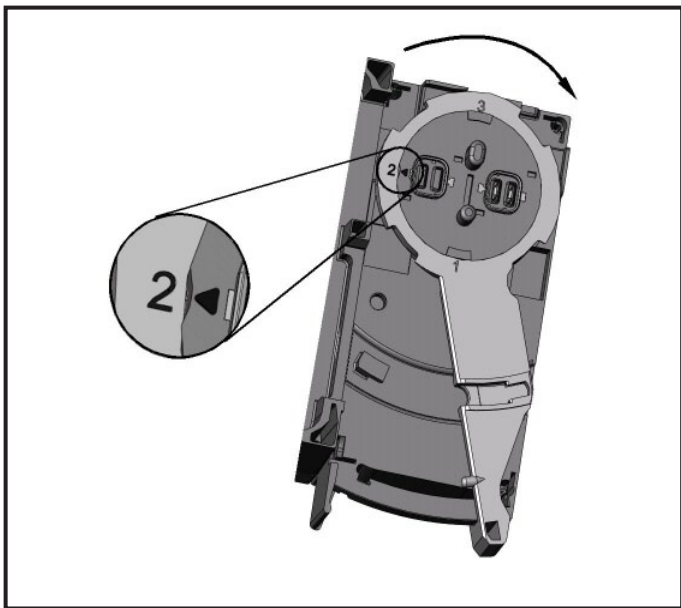

Settings at the upper part

Then set the selected position at the upper part. To do so, turn the arrow to the corresponding number (figure D1 and D2).

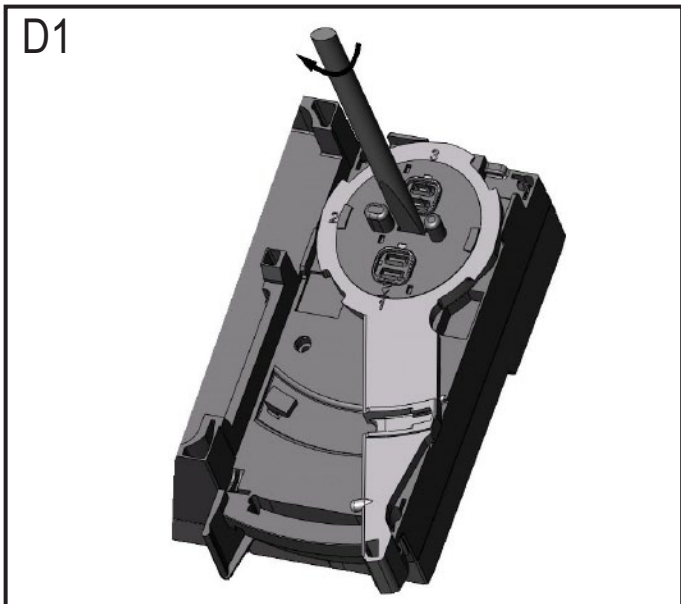

Use a tool, e.g. a screwdriver (figure D1) or the yellow / black flat cable guide (figure D2).

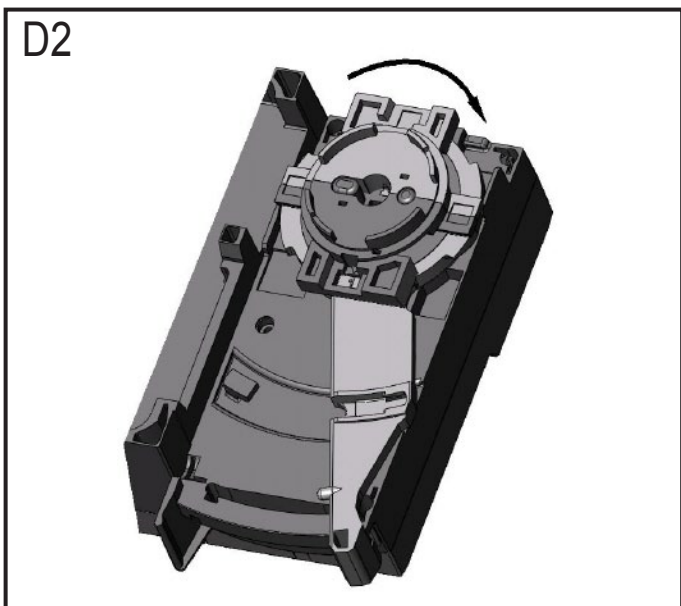

Open the unit

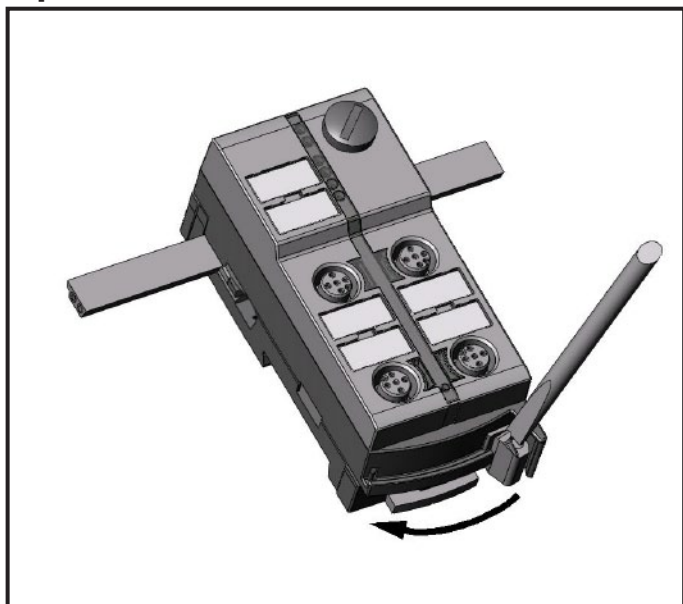

Open the unit using a tool as shown (e.g. screwdriver).

UK

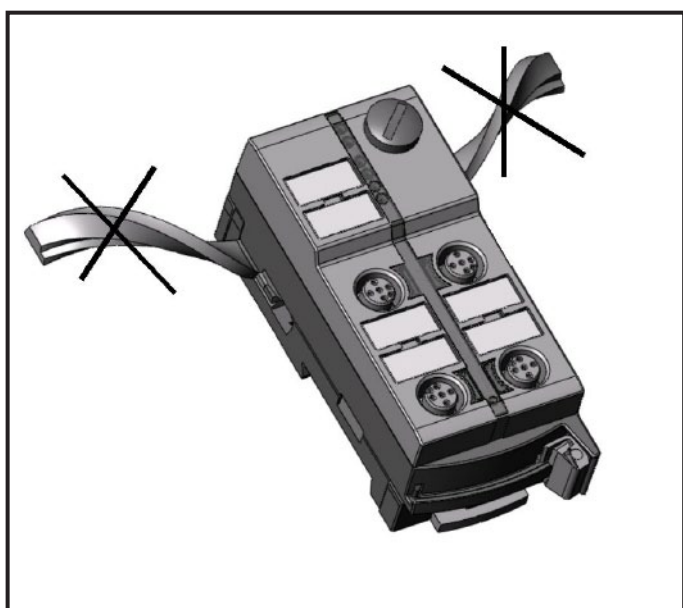
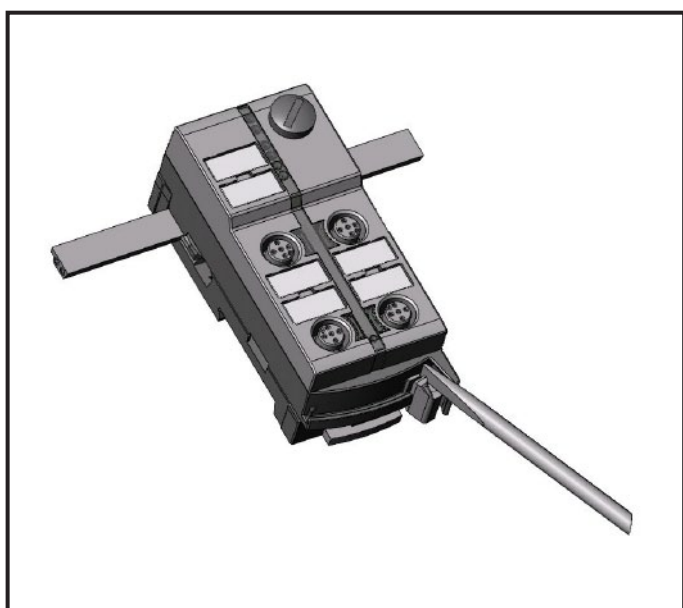

Take care in laying the AS-i flat cable, the flat cable should be laid straight for about 15 cm.

5 Addressing

At the factory the address is set to 0.

5.1 Addressing with the AC1154 addressing unit

When mounted and wired the module can be addressed with the addressing cable (E70213) via the implemented addressing interface.

6 Current measurement

In all the following wiring diagrams the indicated pin connection refers to the analogue module.

Connection of a 2-wire sensor without own supply

- Pin 1: sensor supply +24 V
- Pin 2: AI+ analogue input
- Pin 3: sensor supply 0 V / analogue input AI-
- Pin 5: functional earth

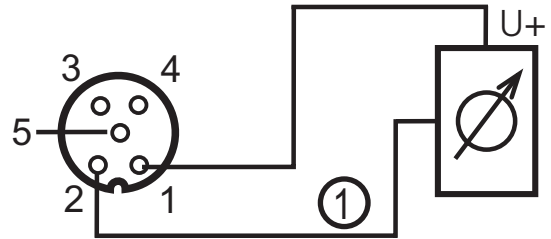

1. analogue in current

Wiring of a 2-wire sensor with electrically isolated and earth-free supply

- Pin 1: sensor supply +24 V
- Pin 2: AI+ analogue input
- Pin 3: sensor supply 0 V / analogue input AI-
- Pin 5: functional earth

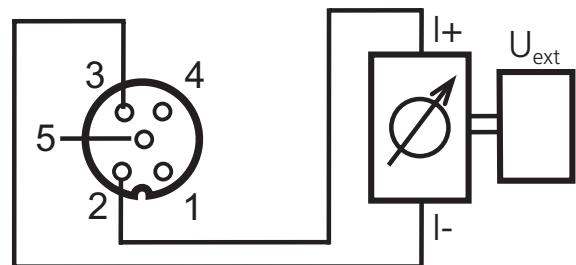

Connection of a 3-wire sensor without own supply

- Pin 1: sensor supply +24 V
- Pin 2: AI+ analogue input
- Pin 3: sensor supply 0 V / analogue input AI-
- Pin 5: functional earth

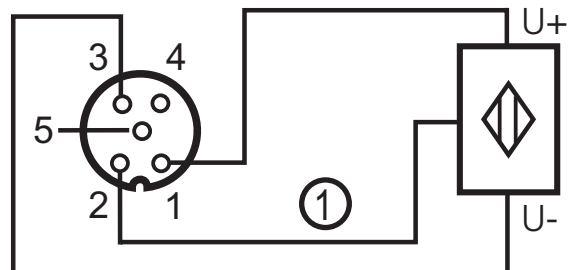

1. analogue in current

7 Parameter setting of the analogue module

Parameter bit/ Designation	Description		Remarks
P0 filter	1*	50Hz filter in the A/D converter active	The 50Hz filter applies to the whole of Europe
	0	60Hz filter in the A/D converter active	
P1 channel 2	1	channel 2 enabled	The projection has an effect on the conversion time in the AS-i slave, the transmission via the AS-interface, the LED function and on the peripheral fault messages. The LED indication and peripheral fault messages are no longer affected by this channel. By disabling channel 2 the conversion time in the slave can be reduced considerably.
	0	channel 2 not enabled	
P2 peripheral fault	1	peripheral fault active	* default setting
	0	peripheral fault not active	
P3 not used	1	reserved	
	0	reserved	

UK

8 Electrical connection

Connect the plugs of the sensors / actuators to the M12 sockets. Cover the unused sockets with protective caps (E73004)*, the addressing socket with the supplied protective cap. Tightening torque 0.8 Nm.

The flat cable end seal (E70413)* must be used if the module is at the end of the cable line. * to be ordered separately

The earthing lead (2.8 x 0.5 mm) on the supplied lower part is connected to pin 5, functional earth of the M12 sockets.

9 Operation



Avoid build-up of dirt and dust on the upper and lower parts so that the locking mechanism is not affected.

• LED green PWR on:	AS-i voltage is applied
• LED red FAULT on:	AS-i communication error
• LED red FAULT flashes:	peripheral fault*
• LED1 yellow off:	sensor input disabled (see parameter bit P1)
• LED1 yellow on:	analogue signal in the measuring range
• LED1 yellow flashes:	analogue signal outside the measuring range or no sensor connected

* peripheral fault

A peripheral fault is displayed:

- if at least one of the analogue signals is outside the value range
- if nothing is connected to at least one analogue channel although the respective channel (P2) is enabled
- in case of overload or short circuit of the sensor supply

10 Measuring range of the module

For the measuring range and its significance please refer to the following tables:

Analogue input module 4...20 mA

Range [mA]	Units dec.	Units hex.	LED	Peripheral fault	Meaning
< 3.4	32768 → 32767 *	8000 → 7FFF *	flashes	on***	wire break
3.4...3.59	3400...3599 → 32767 *	0D48...0E0F → 7FFF *	flashes	off	below nominal range
3.6...22	3600.. 22000	0E10.. 55F0	on	off	extended and nominal range**
22.01...23	22001...23000 → 32767 *	55F1.. 59D8 → 7FFF *	flashes	off	above nominal range
> 23	32767	7FFF	flashes	on***	outside range

Note:

* the master replaces the value transmitted by the slave with the default value 7FFFh (32767)

** the accuracy is only achieved in the nominal range (4...20 mA), it is not guaranteed in the extended nominal range.

*** only for parameter bit 2 = 1

11 Technical data

Technical data and further information at
www.ifm.com

UK