



CE

Original operating instructions
SafetyController

CR7032

UK

80004328 / 00 08 / 2017

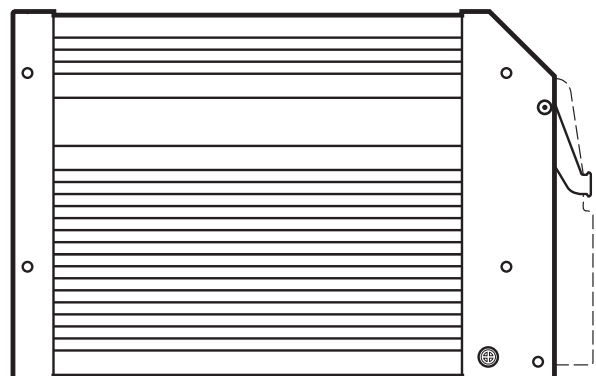

Bestimmungsgemäße Verwendung

Die freiprogrammierbaren Steuerungen der Baureihe "SafetyController" sind für den Einsatz unter erschwerten Bedingungen ausgelegt. Sie sind geeignet zum direkten Einbau in Fahrzeugen und mobilen Arbeitsmaschinen unter Verwendung des Bordnetzes (12/24 V DC Batteriebetrieb).

Zusätzlich sind in den durch diese Anleitung beschriebenen Steuerungen für sicherheitsrelevante Aufgaben spezielle Hard- und Softwarefunktionen integriert, die einen Einsatz als Sicherheitssteuerung ermöglichen.

DE

⚠️ WARNUNG

Die Steuerungen "SafetyController" sind für sicherheitsrelevante Aufgaben im Sinne des Personenschutzes zugelassen, wenn die entsprechenden Systemprüfroutinen in das Betriebssystem und die Applikationssoftware eingebunden werden und durch einen vollständigen Funktionstest geprüft wurden.

Die endgültige Einstufung und Freigabe eines Systems (Hard- und Software) darf aber nur durch die entsprechenden Überwachungsorganisationen erfolgen.

Programmierung und wesentliche Ergänzungen zu dieser Anleitung

Neben dem Programmiersystem CODESYS und dem Softwaretool "Downloader" werden zur Inbetriebnahme und Programmierung der Steuerung folgende Dokumente benötigt:

- "Wichtige Hinweise zum CR7n32" für die von Ihnen verwendeten Softwarestände
- Systemhandbuch "SafetyController"
- Programmierhandbuch "CODESYS"

Sollten Ihnen diese Dokumente nicht vorliegen, können Sie diese in Deutsch oder Englisch auf der angegebenen Homepage per Internet oder unter der unten angegebenen Anschrift, per E-Mail, per Telefax, per Telefon oder per Post unentgeltlich anfordern.

Internet	www.ifm.com/de Datenblattsuche → Art.-Nr. → weitere Informationen
Anschrift	ifm electronic gmbh • Friedrichstraße 1 • 45128 Essen
E-Mail	info@ifm.com
Telefax	0800 16 16 16 5 (kostenlose Fax-Hotline)
Telefon	0800 16 16 16 4 (kostenlose Service-Hotline)

Inbetriebnahme

Das Gerät darf nur durch fachkundiges Personal in Betrieb genommen werden.

Wir weisen zudem ausdrücklich darauf hin, dass jegliche Haftung ausgeschlossen ist, wenn die entsprechenden Hinweise in den Dokumentationen für die Inbetriebnahme und Programmierung nicht beachtet werden.

Functions and features

The programmable controllers of the series "SafetyController" are designed for use in safety-related applications. They are suitable for direct installation in vehicles and mobile machines using the on-board system (12/24 V DC battery operation).

Special hardware and software functions are integrated into the controllers for safety-related applications, as described in these instructions. This enables the use as a safety controller.

⚠ WARNING

The "SafetyController" devices are approved for safety-related tasks in the field of operator protection, if the corresponding system check routines are integrated in the operating system and the application software and have been checked by a complete function test. However, the final classification and approval of a system (hardware and software) may only be carried out by the corresponding supervisory organisations.

UK

Programming and important additions to these instructions

In addition to the programming system CODESYS and the software tool "Downloader", the following documents are required for programming and commissioning of the controller:

- "Important notes on CR7n32" for the software versions used by you
- System manual "SafetyController"
- Programming manual "CODESYS"

If you do not have these documents, you can request them in German or English free of charge on the indicated website or via e-mail, fax, phone or post at the address stated below.

Internet	www.ifm.com/uk
	Data sheet search → Order no. → More information
Address	ifm electronic ltd. efactor House • Kingsway Business Park • Oldfield Road Hampton • Middlesex TW12 2HD
E-mail	enquiry_gb@ifm.com
Fax	020 8213-0001
Telephone	020 8213-0000

Set-up

Only qualified staff is allowed to set up the device.

Furthermore we expressly point out that any liability is excluded if the notes in the programming and set-up documents are not adhered to.

Fonctionnement et caractéristiques

Les systèmes de contrôle-commande programmables de la série " SafetyController " sont conçus pour l'emploi dans des conditions sévères.

Ils sont appropriés pour l'installation directe dans des véhicules et des engins mobiles en utilisant le système à bord (batterie 12/24 V DC).

De plus, des fonctions matériel et logiciel spécifiques sont intégrées dans les systèmes de contrôle-commande pour des applications de sécurité et décrites dans cette notice permettant un emploi comme système de contrôle-commande de sécurité.

⚠ AVERTISSEMENT

Les automates programmables " SafetyController " sont homologués pour des tâches de sécurité dans le sens de la protection des personnes si les routines systèmes correspondantes sont intégrées dans le système d'exploitation et le logiciel d'application et ont été testées à l'aide d'un test fonctionnel complet.

Cependant, la classification définitive et l'homologation d'un système (matériel et logiciel) ne doivent être effectuées que par les organismes de contrôle correspondants.

FR

Programmation et ajouts importants à cette notice

Outre le système de programmation CODESYS et l'outil logiciel " downloader ", les documents suivants sont nécessaires pour la mise en service et la programmation du système contrôle-commande :

- " Remarques importantes pour CR7n32 " pour les versions du logiciel que vous utilisez
- Manuel du système " SafetyController "
- Manuel de programmation " CODESYS "

Si vous n'avez pas ces documents, vous pouvez les demander en allemand ou anglais gratuitement sur le site web indiqué ou par e-mail, fax, téléphone ou courrier à l'adresse indiquée.

Internet	www.ifm.com/fr
	Fiche technique → N° de commande → Plus de détail
Adresse	ifm electronic - Agence Paris • Immeuble Uranus • 1-3 rue Jean Richepin 93192 NOISY LE GRAND CEDEX
E-mail	info.fr@ifm.com
Fax	0820 22 22 04
Téléphone	0820 22 30 01

Mise en service

L'appareil ne doit être mis en service que par un personnel compétent.

De plus, nous signalons expressément que toute responsabilité est exclue si les remarques correspondantes dans les documents de programmation et de mise en service ne sont pas respectées.

Uso conforme

I sistemi di controllo programmabili della serie "SafetyController" sono concepiti per l'uso in condizioni difficili. Sono adatti per il montaggio diretto in veicoli e macchine mobili utilizzando l'impianto elettrico di bordo (con batteria 12/24 V DC).

Inoltre speciali funzioni hardware e software sono integrate nei sistemi di controllo per applicazioni di sicurezza, descritti nel presente manuale, permettendone un impiego come sistemi di controllo di sicurezza.

! ATTENZIONE

I sistemi di controllo "SafetyController" sono omologati per applicazioni di sicurezza rivolte alla protezione di persone se le corrispondenti verifiche di routine del sistema vengono integrate nel sistema operativo e nel software applicativo e sono state controllate mediante un test funzione completo.

Tuttavia la classificazione definitiva e l'omologazione di un sistema (hardware e software) devono essere eseguite soltanto tramite gli enti di controllo corrispondenti.

IT

Programmazione e supplementi rilevanti per questo manuale

Oltre al sistema di programmazione CODESYS e al software "Downloader" sono necessari i seguenti documenti per la messa in funzione e la programmazione del sistema di controllo:

- "Indicazioni importanti relative al CR7n32" per le versioni software utilizzate
- manuale del sistema "SafetyController"
- manuale di programmazione "CODESYS"

Se non si possiede questa documentazione, è possibile richiederla gratuitamente in tedesco o in inglese sul sito web indicato oppure per posta all'indirizzo di cui sotto, per e-mail, per fax o per telefono.

Internet	www.ifm.com/it
	Scheda tecnica → N. d'ordine → Informazione sul prodotto
Indirizzo	ifm electronic srl • Centro Dir. Colleoni • Andromeda 2 • Via Paracelso No. 18 20041 Agrate Brianza (MB)
E-Mail	info.it@ifm.com
Telefax	039 689 99 95
Telefono	039 689 99 82

Messa in funzione

Il sistema deve essere messo in funzione soltanto da personale esperto.

Facciamo espressamente presente che si declina ogni responsabilità qualora non vengano rispettate le indicazioni corrispondenti nella documentazione per la programmazione e la messa in funzione.

Utilización correcta

Los controladores programables de la gama "SafetyController" están concebidos para su utilización bajo condiciones difíciles. Son aptos para una instalación directa en vehículos y máquinas móviles utilizando la red de a bordo (funcionamiento con batería de 12/24 V DC). En los controladores para aplicaciones de seguridad descritos en estas instrucciones también están integradas funciones especiales de hardware y software, las cuales posibilitan la utilización como controlador de seguridad.

⚠ ADVERTENCIA

Los controladores "SafetyController" están homologados para aplicaciones de seguridad relativas a la protección de personas, siempre y cuando las rutinas de verificación del sistema estén integradas en el sistema operativo y en el software de aplicación y sean examinadas mediante un test completo de funcionamiento.

Sin embargo, la clasificación definitiva y la autorización de un sistema (hardware y software) solamente puede llevarse a cabo a través de los correspondientes organismos de control.

ES

Programación y suplementos fundamentales de estas instrucciones

Además del sistema de programación CODESYS y de la herramienta "Downloader", para la puesta en marcha y programación del controlador son necesarios los siguientes documentos:

- "Indicaciones importantes sobre el CR7n32" para las versiones de software que usted utiliza
- Manual del sistema "SafetyController"
- Manual de programación "CODESYS"

En caso de que usted no disponga de esta documentación, puede solicitarla de forma gratuita en los idiomas alemán e inglés a través de los medios que se indican a continuación: página web, correo electrónico, fax, teléfono o dirección postal.

Internet	www.ifm.com/es Ficha técnica → N° de pedido → Información sobre productos
Dirección	ifm electronic s.a. • Edificio Prima Muntadas A • Parc Mas Blau • C/Berguedà 1 08820 El Prat de Llobregat
E-mail	info.es@ifm.com
Fax:	(+ 34) 93.479.30.86
Teléfono	(+ 34) 93.479.30.80

Puesta en marcha

El equipo solo puede ser puesto en marcha por personal especializado.

Advertimos expresamente de que queda excluida toda responsabilidad en caso de que no se observen las correspondientes indicaciones descritas en la documentación de programación y puesta en marcha.

Utilização adequada

Os controladores livremente programáveis da série "SafetyController" destinam-se à utilização em condições difíceis. Eles são adequados para a montagem direta em veículos e máquinas móveis usando a rede elétrica própria (operação com bateria 12/24 V DC). Além disso, os controladores destinados a tarefas de segurança, descritos no presente manual, integram funções especiais de hardware e software, que permitem a sua utilização como controladores de segurança.

⚠ AVISO

Os controladores "SafetyController" estão aprovados para tarefas no campo da segurança de pessoas, se as respectivas rotinas de controlo do sistema forem incluídas no sistema operativo e no software de aplicação e se tiverem sido submetidos a um teste completo de funcionamento. Contudo, a classificação final e a homologação do sistema (hardware e software) apenas podem ser efectuadas pelas respectivas entidades de controlo.

Programação e complementos essenciais deste manual

Além do sistema de programação CODESYS e a ferramenta de software "Downloader" são necessários os seguintes documentos para a colocação em funcionamento e a programação do controlador:

- "Avisos importantes sobre o CR7n32" para as versões de software que você usa
- Manual de sistema "SafetyController" (controlador de segurança)
- Manual de programação "CODESYS"

Caso não disponha desta documentação, é possível solicitá-la gratuitamente em língua alemã ou inglesa através da página de Internet ou dos seguintes endereços e contactos de email, telefax, telefone e correio:

Internet	www.ifm.com/pt
	Ficha técnica → no. do pedido → outros dados
Endereço	ifm electronic sucursal em Portugal • Avenida da República 2503 Sala 324430-208 Vila Nova de Gaia
E-Mail	info.pt@ifm.com
Fax	0223 71 71 10
Telefone	0223 71 71 08

Colocação em funcionamento

O produto só deve ser colocado em funcionamento por pessoal especializado. Chamamos ainda expressamente à atenção que não assumimos quaisquer responsabilidades em casos de falta de incumprimento das indicações da documentação relativas à programação e colocação em funcionamento.

Gebruik volgens de voorschriften

De vrij te programmeren besturingen van de bouwserie "SafetyController" zijn ontworpen voor gebruik onder zware omstandigheden. Ze zijn direct te plaatsen in voertuigen of mobiele installaties die gebruik maken van een on-board systeem (12/24 V DC accu systemen).

Bovendien zijn in de in deze handleiding beschreven besturingen, voor taken die relevant zijn voor de veiligheid, speciale hard- en softwarefuncties geïntegreerd. Deze functies maken een gebruik als veiligheidsbesturing mogelijk.

⚠ WAARSCHUWING

De besturingen onder de naam "SafetyController" zijn toegelaten voor taken die relevant zijn voor de veiligheid, in de zin van bescherming van personen, wanneer de betreffende systeemtestfuncties in het besturingssysteem en de applicatiesoftware geïntegreerd worden en door een volledige functietest gecontroleerd zijn.

De definitieve classificatie en de vrijgave van het systeem (hard- en software) mogen echter alleen geschieden door de desbetreffende keuringsinstanties.

Programmering en belangrijke aanvullingen op deze handleiding

NL

Als toevoeging op de programmeer omgeving CODESYS en software tool "downloader", zijn de volgende documenten nodig om de controller te programmeren en te autoriseren:

- Belangrijke mededelingen betreffende de CR7n32 voor de door u toegepaste software versies.
- Systeemhandboek "SafetyController"
- Programmeerhandboek "CODESYS"

Zijn deze documenten niet aanwezig, dan kunt u deze in het Duits of Engels op de aangegeven internetpagina of op het hieronder aangegeven adres per e-mail, fax, telefoon of post gratis aanvragen.

Internet	www.ifm.com/nl
	Datablad → Bestelnummer → Aanvullende informatie
Adres	ifm electronic b.v. • Deventerweg 1 E • 3843 GA HARDERWIJK
E-mail	info.nl@ifm.com
Fax	0341 - 438 430
Telefoon	0341 - 438 438

Inbedrijfstelling

Het product mag uitsluitend door deskundig personeel in gebruik genomen worden. Wij wijzen er bovendien uitdrukkelijk op, dat elke aansprakelijkheid uitgesloten is wanneer de desbetreffende aanwijzingen in de documenten voor de programmering en inbedrijfstelling niet in acht genomen worden.

Brug i overensstemmelse med formålet

De frit programmérbare styringer i serien "SafetyController" er konstrueret til brug under vanskelige forhold. De er velegnede til direkte montering i køretøjer og mobile maskine. Maskinens eksisterende strømforsyning må benyttes (12/24 V DC batteridrift).

Til sikkerhedsrelevante opgaver er der i de styringer, der beskrives i denne vejledning, derudover integreret specielle hard- og softwarefunktioner, der muliggør en brug som sikkerhedsstyring.

⚠ ADVARSEL

Styringerne "SafetyController" er godkendt til sikkerhedsrelevante opgaver i henhold til personsikkerhed, hvis de tilsvarende systemkontrolrutiner integreres i operativsystemet og applikationssoftwaren samt afprøves med en komplet funktionstest.

Den endelige klassificering og frigivelse af systemet (hard- og software) må dog kun foretages af de pågældende kontrolorganisationer.

Programmering og væsentlige supplementer til denne vejledning

Ud over programmerings systemet CODESYS og software-værktøjet "downloader," kræves der følgende dokumenter for programmering og idriftsættelse af controlleren:

- "Vigtige oplysninger vedrørende CR7n32" i forbindelse med de software-versioner du anvender
- Systemhåndbog "SafetyController"
- Programmeringshåndbog "CODESYS"

Hvis disse dokumentationer ikke foreligger, kan de bestilles gratis på tysk eller engelsk via internet på den anførte hjemmeside eller via e-mail, telefax, telefon eller post på følgende adresse.

Internet	www.ifm.com/dk
	ifm datablad direkte → bestil. nr. → Mere
Adresse	ifm electronic a/s • Ringager 4A, 1.sal tv. • DK-2605 Brøndby
E-mail	info.dk@ifm.com
Fax	70 20 11 09
Telefon	70 20 11 08

Ibrugtagning

Udstyret må kun tages i brug af fagkyndigt personale.

Vi gør derudover udtrykkeligt opmærksom på, at vi fralægger os ethvert ansvar, hvis de pågældende henvisninger i dokumentationen ikke overholdes ved programmeringen og ibrugtagningen.

Toiminnot ja ominaisuudet

"SafetyController" -laitesarjan vapaasti ohjelmoitavat ohjausjärjestelmät on suunniteltu käytettäväksi vaativissa olosuhteissa. Ne voidaan asentaa suoraan ajoneuvoihin ja liikkuviin työkoneisiin, joissa on 12/24 V DC sähköjärjestelmä (akkukäyttö).

Lisäksi tässä ohjeessa kuvattuihin turvallisuuteen liittyviin sovellutuksiin tarkoitettuihin ohjausjärjestelmiin on integroitu erityisiä laitteisto- ja ohjelmistotoimintoja, jotka mahdollistavat käytön turvaohjausjärjestelmänä.

⚠ VAROITUS

"SafetyController"-ohjausjärjestelmät on hyväksytty käytettäväksi turvallisuuden kannalta tärkeissä henkilösuojaustehtävissä, jos vastaavat järjestelmän tarkastusrutiinit on integroitu käyttöjärjestelmään ja sovellutusohjelmisto on läpäissyt täydellisen toimintatestin. Järjestelmän (laitteisto ja ohjelmisto) lopullisen luokituksen ja hyväksymisen saavat kuitenkin suorittaa ainoastaan vastaavat tarkastusorganisaatiot.

Ohjelmointi ja tärkeitä lisäyksiä näihin käyttöohjeisiin

CODESYS-ohjelmointijärjestelmän ja "downloader"-lataustyökalun lisäksi controllerin ohjelmoinnissa ja käyttöönotossa tarvitaan seuraavat dokumentit:

- "Tärkeitä huomautuksia laitteelle CR7n32" koskien käyttämiäsi ohjelmistoversioita
- Järjestelmäkäsikirja "SafetyController"
- Ohjelmointikäsikirja "CODESYS"

Jollei sinulla ole näitä dokumentteja, voit tilata ne veloitusetta saksan- tai englanninkielisenä alla ilmoitetulta web-sivustolta tai sähköpostilla, faksilla tai puhelimitse alla mainitusta osoitteesta.

Internet	www.ifm.com/fi Data sheet direct → Tilausnumero → Lisätietoja
Osoite	ifm electronic oy • Vaakatie 5 • 00440 Helsinki
Sähköposti	info.fi@ifm.com
Faksi	+358 (0)75 329 5010
Puhelin	+358 (0)75 329 5000

Käyttöönotto

Laitteen käyttöönoton saa suorittaa ainoastaan turvateknisen koulutuksen saanut henkilö. Haluamme lisäksi korostaa, että ohjelmointi- ja käyttöönottodokumenttien ohjeiden noudattamatta jättäminen johtaa kaikkien takuiden ja vastuiden raukeamiseen.

Funktion och egenskaper

Programmerbara controllers i produktserien "SafetyController" är konstruerade för användning i tuffa förhållanden. De är lämpliga för att installeras i fordon och på mobila maskiner direkt mot maskinens interna elsystem (12/24 V DC).

Controllers för säkerhetsrelaterade applikationer, som beskrivs i denna anvisning, har särskilt integrerade hård- och mjukvarufunktioner som möjliggör deras användning som säkerhetscontroller.

⚠ VARNING

"SafetyController"-enheterna är godkända för säkerhetsrelaterade uppgifter inom området personskydd om de relevanta systemkontrollrutinerna integreras i operativsystemet och applikationsmjukvaran, och dessa har kontrollerats genom en fullständig funktionstest. Slutgiltig klassificering och godkännande av ett system (hårdvara och mjukvara) får dock endast utfärdas av relevanta övervakningsorganisationer.

Programmering och viktiga tillägg till dessa instruktioner

Utöver utvecklingsmiljön CODESYS och programvaran "downloader", behövs följande dokument för programmering och handhavande av controllern:

- "Viktiga anvisningar för CR7n32" gällande de programversioner som används av dig
- Systemhandbok "SafetyController"
- Programmeringshandbok "CODESYS"

Skulle dessa dokument inte finnas till hands, kan de beställas utan kostnad på engelska eller tyska från den angivna hemsidan eller via e-mail, fax, telefon eller per post från nedanstående angivna adresser.

Internet	www.ifm.com/se
	Datablad direkt → Best.nr. → Ytterligare data
Adress	ifm electronic ab • Hallavägen 10 512 60 Överlida
e-post	info.se@ifm.com
Fax	0325-66 15 90
Telefon	0325-66 15 00

SE

Installation

Enheten får endast tas i drift av kvalificerad personal.

Dessutom vill vi uttryckligen påpeka att vi fransäger oss allt ansvar om instruktionerna som ges i dokumentationen för programmering och driftsättning ej beaktas.

Λειτουργία και χαρακτηριστικά

Οι προγραμματιζόμενοι ελεγκτές σειράς "SafetyController" έχουν σχεδιαστεί για χρήση σε αντίξοες συνθήκες. Είναι κατάλληλα για άμεση τοποθέτηση σε οχήματα και κινούμενες μηχανές, χρησιμοποιώντας την πλακέτα συστήματος (12/24 V DC λειτουργία μπαταρίας). Ειδικές λειτουργίες υλικού και λογισμικού είναι επιπρόσθετα ενσωματωμένες στους ελεγκτές για εφαρμογές ασφαλείας και περιγράφονται σε αυτές τις οδηγίες που επιτρέπουν τη χρήση ως ελεγκτή ασφαλείας.

⚠ ΠΡΟΕΙΔΟΠΟΙΗΣΗ

Οι συσκευές "SafetyController" εγκρίνονται για εργασίες ασφαλείας στον τομέα της προστασίας χειριστών εάν οι αντίστοιχες ρουτίνες ελέγχου συστημάτων είναι ενσωματωμένες στο λειτουργικό σύστημα και τα προγράμματα εφαρμογών και έχουν ελεγχθεί από μια πλήρη δοκιμή λειτουργίας.

Εντούτοις, η τελική ταξινόμηση και η έγκριση ενός συστήματος (υλικό και λογισμικό) μπορούν να πραγματοποιηθούν μόνο από τις αντίστοιχες εποπτικές οργανώσεις.

Προγραμματισμός και σημαντικές προσθήκες σε αυτές τις οδηγίες

Επιπρόσθετα από το σύστημα προγραμματισμού CODESYS και το εργαλείο λογισμικού "downloader", απαιτούνται και τα ακόλουθα έγγραφα για τον προγραμματισμό και την έναρξη λειτουργίας του ελεγκτή:

- "Σημαντικές σημειώσεις σχετικά με το CR7n32 ", για τις εκδόσεις λογισμικού που χρησιμοποιείται από εσάς
- Εγχειρίδιο συστήματος "SafetyController"
- Εγχειρίδιο προγραμματισμού "CODESYS"

Εάν δεν έχετε αυτά τα έγγραφα, μπορείτε να τα ζητήσετε στα Γερμανικά ή Αγγλικά δωρεάν στον υποδειγμένο ιστοχώρο ή μέσω ηλεκτρονικού ταχυδρομείου, φαξ, τηλεφώνου ή στην κάτωθι διεύθυνση.

GR

Διαδίκτυο	www.ifm.com/gr Αναζήτηση τεχνικού φυλλαδίου → Κωδικός παραγγελίας → Άλλες πληροφορίες
Διεύθυνση	ifm electronic Μονοπρόσωπη ΕΠΕ • Τ.Θ. 61407 • 151 06 Αμαρούσιο - The Mall
E-Mail:	info.gr@ifm.com
Φαξ:	210 61 99 400
Τηλέφωνο:	210 61 80 090

Προετοιμασία για λειτουργία

Μόνο εξειδικευμένο προσωπικό επιτρέπεται να ρυθμίσει τη συσκευή.

Επιπλέον ρητώς επισημαίνουμε ότι οποιαδήποτε ευθύνη αποκλείεται εάν δεν υιοθετούνται οι σημειώσεις στα έγγραφα προγραμματισμού και οργάνωσης.

Contents

1	Preliminary note	4
1.1	Symbols used	4
1.2	Warning signs used	4
2	Safety instructions	5
2.1	General	5
2.2	Target group	5
2.3	Electrical connection	5
2.4	Housing temperature	5
2.5	Tampering with the device	5
2.6	Electromagnetic compatibility	5
2.7	Electrical welding on vehicles and plants	5
3	Functions and features	6
4	Installation	7
4.1	Fixing	7
4.2	Installation position	7
4.3	Mounting surface	8
4.4	Heat dissipation	8
5	Electrical connection	9
5.1	Wiring	9
5.2	Ground connection	9
5.3	Fuses	9
5.4	Laying the supply and signal cables	10
5.5	Frequency and analogue inputs	10
5.6	Supply low-side digital outputs (B _L)	11
5.7	Connection technology	11
5.8	USB interface	12
5.8.1	Hardware requirement	12
5.8.2	Short-circuit protection	12
6	Set-up	13
6.1	Interfaces and system requirements	13
6.2	Programming via USB interface	13
6.2.1	Install the USB drivers	13
6.2.2	Install and define the virtual COM port	16
6.3	Uninstall the drivers	17
7	Technical data	18
7.1	Mechanical and electric data	18
7.2	Test standards and regulations	20
7.3	Input characteristics	21
7.4	Output characteristics	22
7.5	Wiring	23
8	Maintenance, repair and disposal	24

9 Approvals/standards 24



This document is the original instructions.

Licences and trademarks

All trademarks and company names are subject to the copyright of the respective companies.

1 Preliminary note

This document applies to devices of the type "SafetyController" (art. no.: CR7032). These instructions are part of the device.

This document is intended for specialists. These specialists are people who are qualified by their appropriate training and their experience to see risks and to avoid possible hazards that may be caused during operation or maintenance of the device. The document contains information about the correct handling of the device.

Read this document before use to familiarise yourself with operating conditions, installation and operation. Keep this document during the entire duration of use of the device.

Adhere to the safety instructions.

1.1 Symbols used

- ▶ Instructions
- > Reaction, result
- [...] Designation of keys, buttons or indications
- Cross-reference



Important note

Non-compliance can result in malfunction or interference.



Information

Supplementary note

1.2 Warning signs used

WARNING

Warning of serious personal injury.
Death or serious irreversible injuries may result.

CAUTION

Warning of personal injury.
Slight reversible injuries may result.

NOTE

Warning of damage to property.

2 Safety instructions

2.1 General

These instructions are part of the device. They contain information and illustrations about the correct handling of the device and must be read before installation or use.

Observe the operating instructions. Non-observance of the instructions, operation which is not in accordance with use as prescribed below, wrong installation or incorrect handling can seriously affect the safety of operators and machinery.

UK

2.2 Target group

These instructions are intended for authorised persons according to the EMC and low-voltage directives. The unit must be installed, connected and put into operation by a qualified electrician trained in safety technology.

2.3 Electrical connection

The device is designed for supply via a mobile on-board system (12/24 V DC battery operation).

Disconnect the unit externally before handling it. If necessary, also disconnect any independently supplied output load circuits.

The connection terminals may only be supplied with the signals indicated in the technical data and/or on the device label and only the approved accessories of ifm electronic may be connected.

2.4 Housing temperature

As described in the technical specifications below the device can be operated in a wide ambient temperature range. Because of the additional internal heating the housing walls can have high perceptible temperatures when touched in hot environments.

2.5 Tampering with the device

In case of malfunctions or uncertainties please contact the manufacturer. Any tampering with the device can seriously affect the safety of operators and machinery. This is not permitted and leads to the exclusion of any liability and warranty claims.

2.6 Electromagnetic compatibility

This is a class A product. It can cause radio interference in domestic areas. In this case the operator is requested to take appropriate measures.

2.7 Electrical welding on vehicles and plants

Welding work on the chassis frame must only be carried out by qualified persons.

Remove and cover the plus and minus terminals of the batteries.
Disconnect all contacts of the controller from the on-board system prior to welding on the vehicle or plant. Connect the earth terminal of the welding device directly to the part to be welded.

Do not touch the controller or electric cables with the welding electrode or the earth terminal of the welding device.

Protect the controller against weld slag.

3 Functions and features

The freely programmable controllers of the "SafetyController" series are rated for use under difficult conditions (e.g. extended temperature range, strong vibration, intensive EMC interference).

► Observe the operating conditions (→ 7.2 Test standards and regulations).

⚠ WARNING

Observe the introduction (→ pages II ff)!

- Functions and features
- Programming and important additions to these instructions
- Set-up

4 Installation

4.1 Fixing

- Fix the controller to a flat surface using 4 M5 screws.
Screw material: steel or stainless steel
Tightening torque: 8 \pm 2 Nm

NOTE

Use screws with a low head to avoid that the connector is damaged when placed and locked.

UK

Screws to be used (examples)	Standard
Button head hexagon socket screws (M5 x L)	ISO 7380
Cylinder screws with hexagon socket and low head (M5 x L)	DIN 7984
Cutting screws for metric ISO thread with low head	DIN 7500

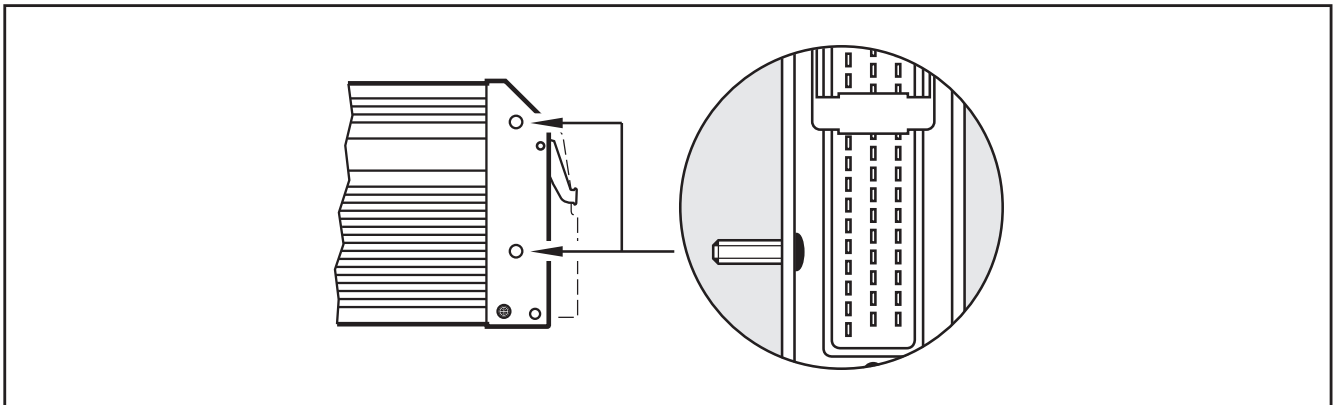

Example button head hexagon socket screw

4.2 Installation position

- Align the controller so that the cable entries of the connectors face downwards.

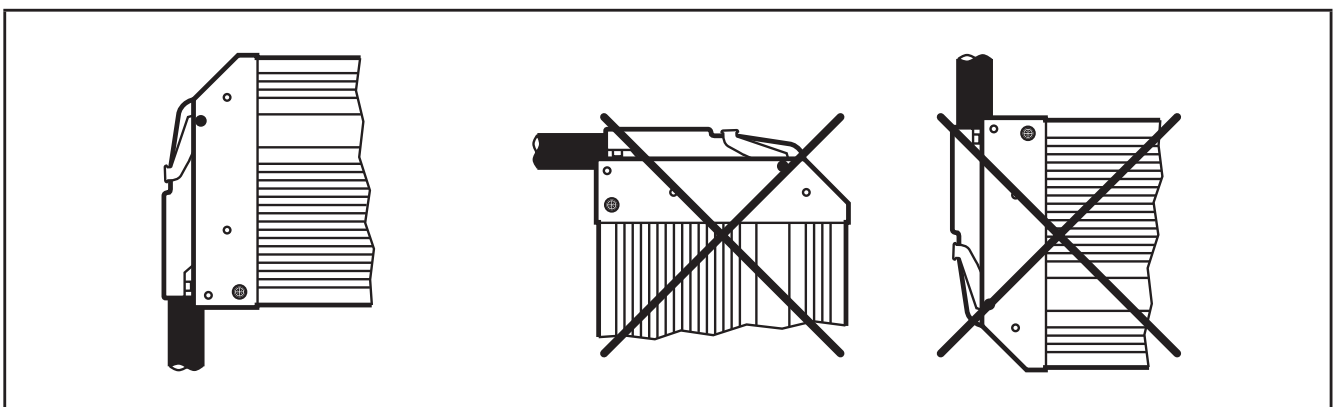

Preferred installation position

4.3 Mounting surface

NOTE

The housing must not be exposed to any torsional forces or mechanical stress.

- ▶ Use compensating elements if there is no flat mounting surface available.

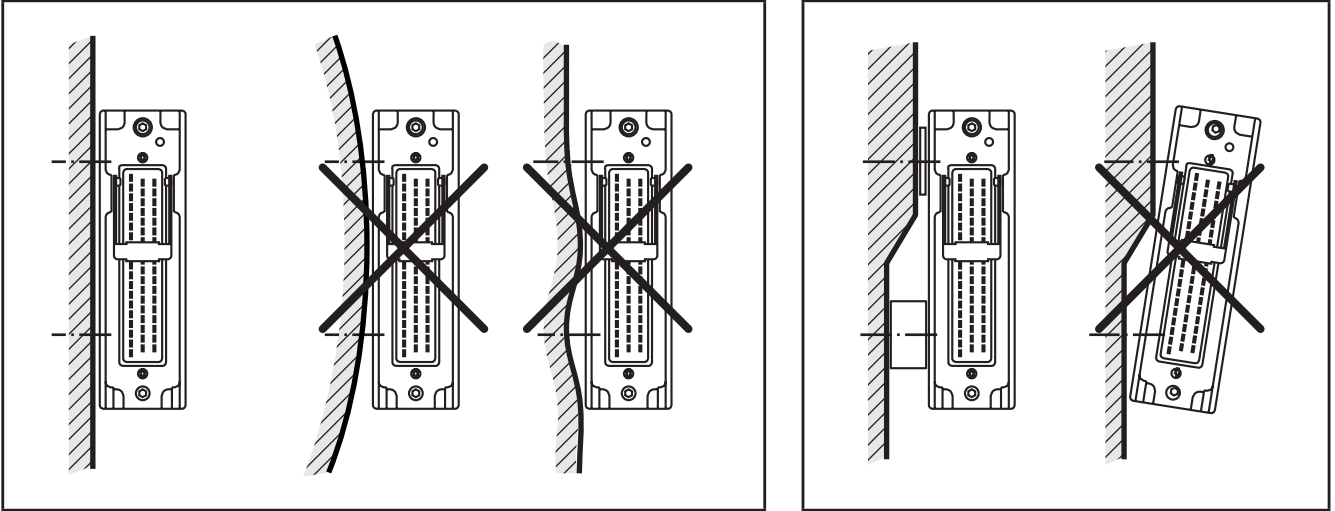

Mounting surface

4.4 Heat dissipation

- ▶ Ensure sufficient heat dissipation as the internal heating of the electronics is conducted away via the housing.
- ▶ In case of sandwich mounting of controllers use spacers.

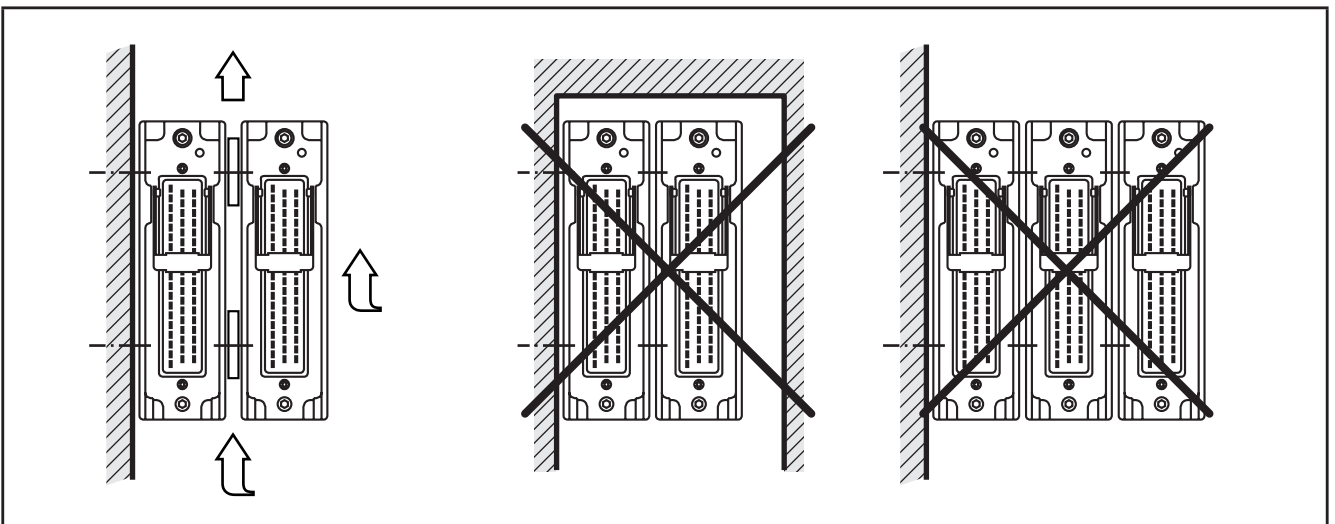

Heat dissipation and sandwich mounting

5 Electrical connection

5.1 Wiring

Wiring (→ 7 Technical data)

! Only connect the connector pins as shown in the pin layout.
Unspecified connector pins remain unconnected.

► Connect all indicated supply cables and GND terminals.

5.2 Ground connection

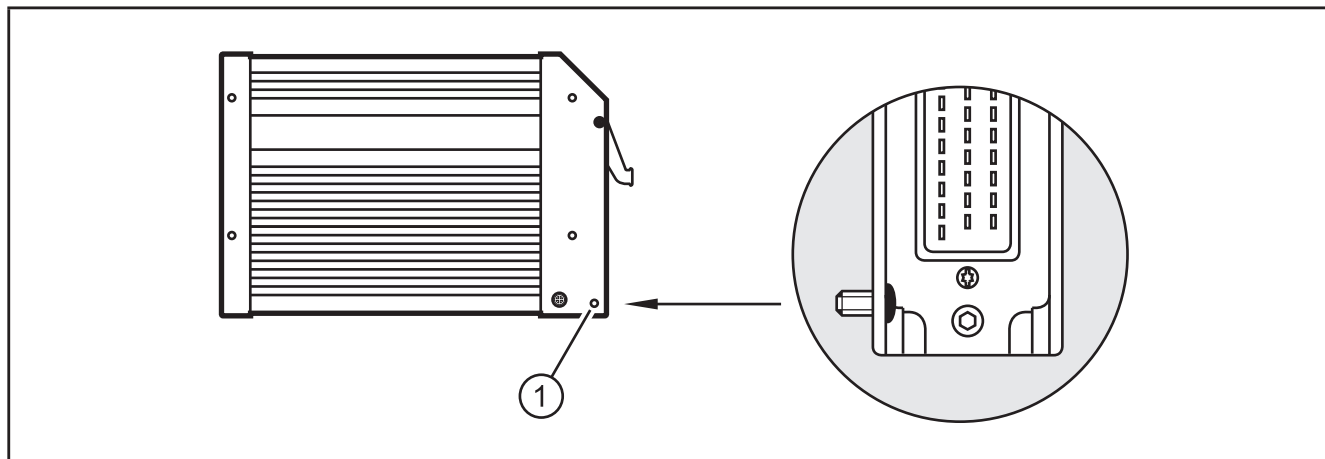

1: Drill hole for ground connection

! To ensure the protection of the device against electrical interference and the safe function of the device, the housing must be connected to the ground of the vehicle.

► Establish a connection between the device and the ground of the vehicle using M5 screws.
Screws to be used (→ 4.1 Fixing)

5.3 Fuses

► The individual electric circuits must be protected in order to protect the whole system.

Potential	Description	Pin no.	Fuse
VBB _S	Supply voltage sensors/module	10	≤ 2 A time-lag
VBB _O	Supply voltage outputs	19	≤ 15 A
VBB _R	Supply voltage via relay	01	≤ 15 A

5.4 Laying the supply and signal cables

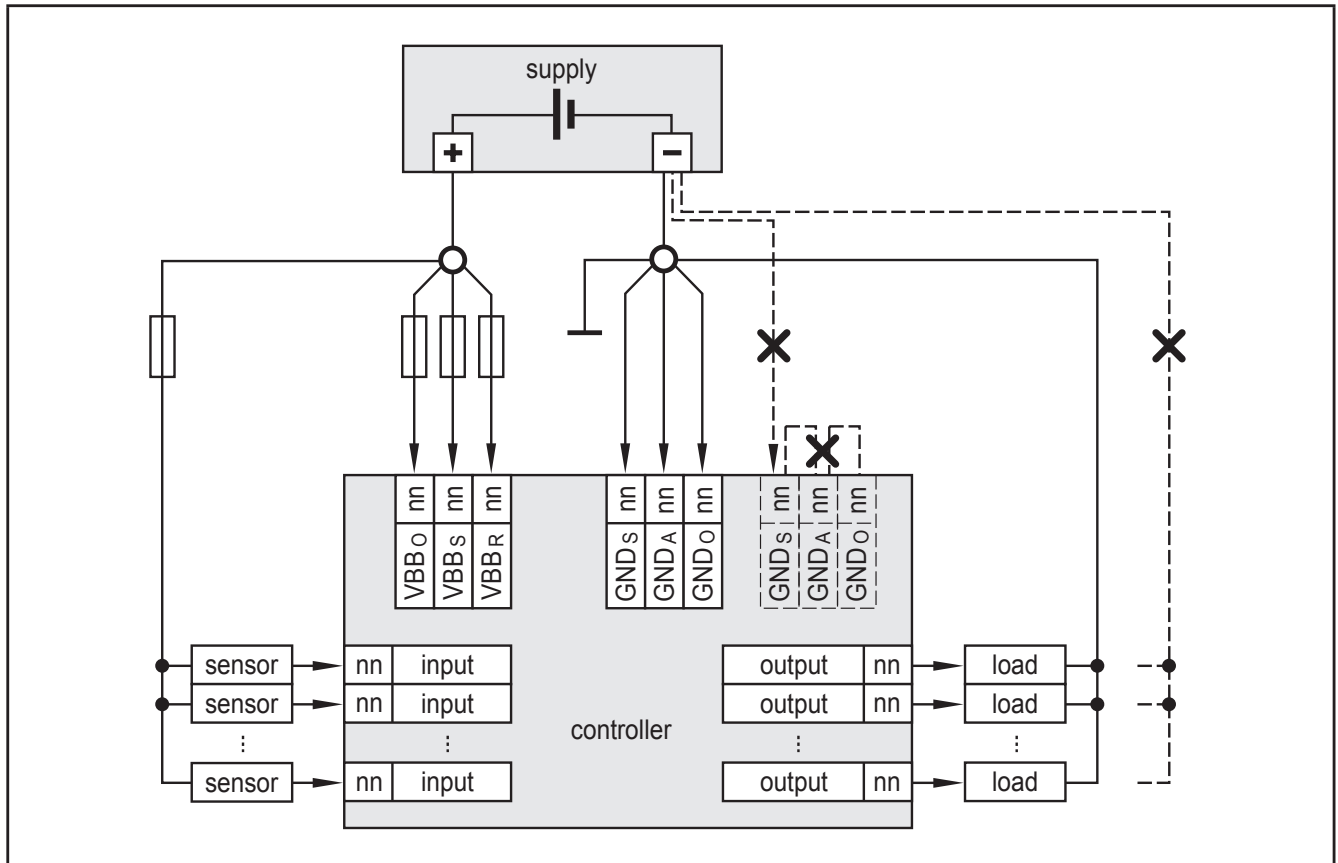

X = not permissible

⚠ WARNING

The linking of connections in the plug is not permitted and can affect the safety of operators and machinery.

- ▶ Basically all supply and signal cables must be laid separately.
- ▶ Connect supply and ground cables to the controller and to the sensors/actuators via the respective common star point.



If a prewired connection cable is used, remove the cores with unused signal inputs and outputs.

Unused cores, in particular core loops, lead to interference coupling that can influence the connected controller.

5.5 Frequency and analogue inputs

- ▶ Operate frequency inputs with screened cables, so that useful signals are not affected by external interference.
- ▶ Connect screens to ground on one side.

5.6 Supply low-side digital outputs (B_L)

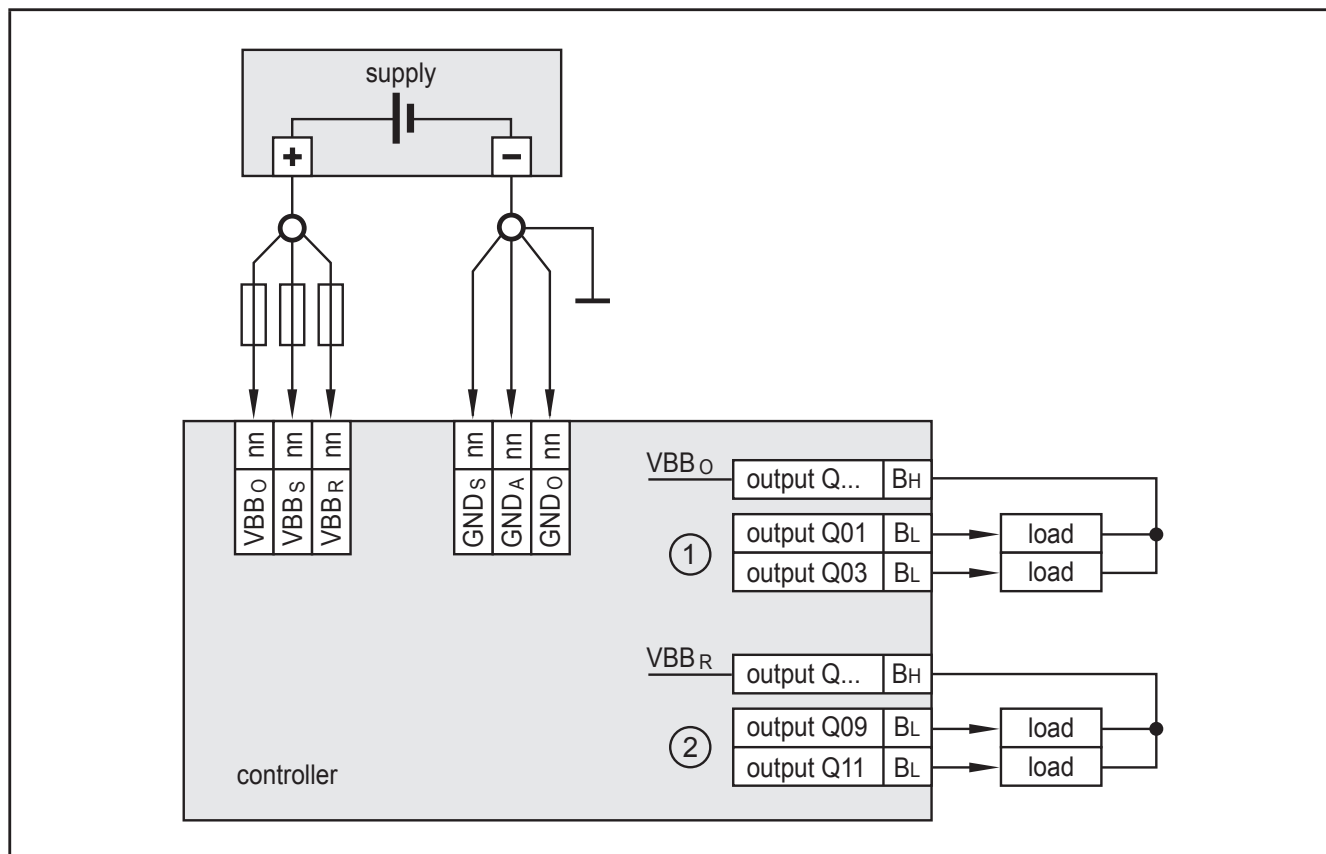

UK

Supply low-side digital outputs (B_L)

- 1: Outputs of the output group VBB_O
- 2: Outputs of the output group VBB_R

- Supply low-side outputs (B_L) via a high-side output (B_H) of the same output group.

5.7 Connection technology

NOTE

Only connect the 55-pole connectors when the supply voltage is disconnected. No "hot plugging" is permitted.

5.8 USB interface

5.8.1 Hardware requirement

The USB controller used is USB 2.0 compatible. The USB interface is provided as a virtual COM port under Windows (→ 6.2 Programming via USB interface).

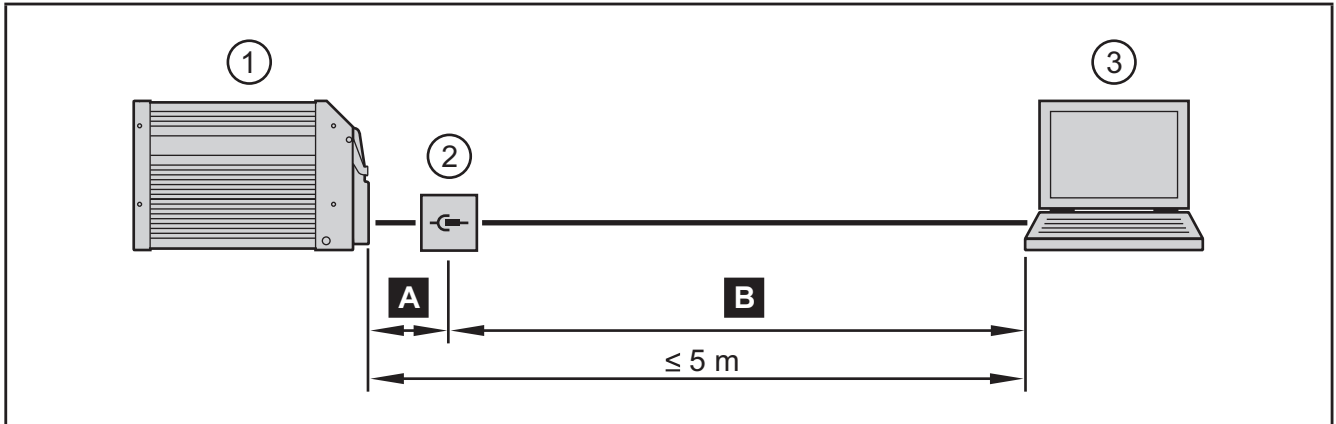

1. Controller (55-pin connector)
2. USB connector for programming and service purposes
3. Notebook/PC

A Connection controller to USB connector, permanent (≤ 3 m).

- ▶ Position the USB connector in immediate vicinity to the controller. The cable length "A" considerably influences the quality of the USB data transmission.

B Connection USB connector to notebook / PC, temporary

- ▶ Use a connection cable with the designation "Full Speed/High Speed" (= USB connection cable with twisted and screened cores).
- ▶ Do not make a connection using several USB connection cables.
- ▶ Remove the connection cable after the programming or service works.

5.8.2 Short-circuit protection

NOTE

The USB interface is not protected against short circuits with a live wire outside the following voltage ranges:

USB_P: -0.5...3.8 V DC

USB_N: -0.5...3.8 V DC

USB_5V: -0.5...10.0 V DC

A short circuit will destruct the USB interface.

6 Set-up

WARNING

Observe the introduction (→ pages II ff)!

- Functions and features
- Programming and important additions to these instructions
- Set-up

6.1 Interfaces and system requirements

The user can easily create the application program by means of the IEC 61131-3 compliant CODESYS programming system.

The "Downloader" software tool is used for the download to the controller. This tool ensures error-free data transfer via redundancy check (CRC).



System requirements for RS-232 and CAN1-4:

Microsoft Windows XP, SP1/2 or higher

System requirements for USB (virtual COM port):

Windows XP, SP2 or higher

6.2 Programming via USB interface



Note in general:

- The controller can be connected to any USB interface. The number of the COM port does not change.
- Only connect one controller for programming to the PC.
- Special USB and COM port drivers are required.

6.2.1 Install the USB drivers

These drivers provide a "virtual COM port", i.e. another artificial serial interface, on the PC.

The drivers can be found on the ifm ecomat mobile CD.



Changes to the system settings of the PC require extended user rights.

Contact your system administrator.



The following descriptions point out the installation under Windows XP. In other Windows versions there may be different menu names or structures.

- ▶ Connect the controller to the PC via the USB interface.
- > When started for the first time, the Windows dialogue box "Found New Hardware Wizard" automatically appears.

UK



- ▶ Select [No, not this time].
(Prevents the automatic search for a new Windows update)
- ▶ Click on [Next] to continue.

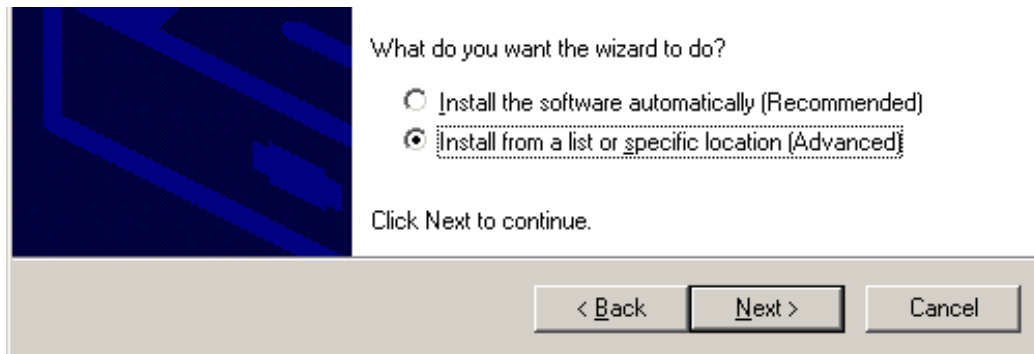

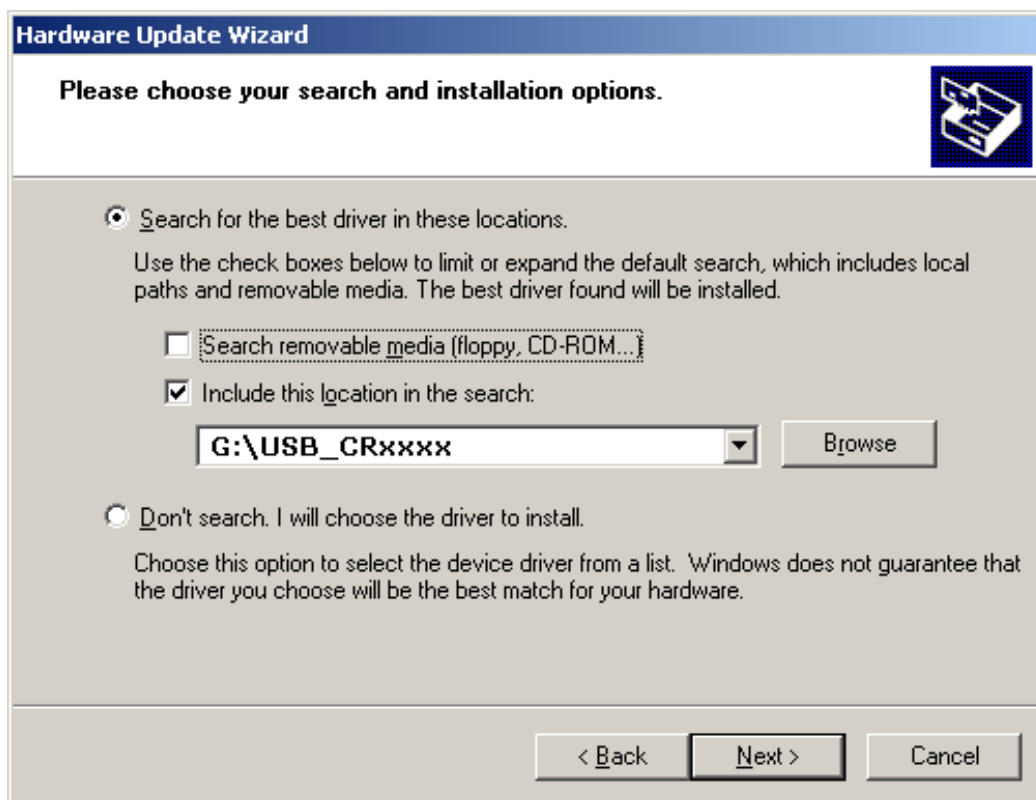

- ▶ Select [Install from a list or specific location].
(Enables the targeted search and selection of the required driver)
- ▶ Click on [Next] to continue.



UK

- ▶ In case of installation using the ecomat mobile CD, select "Include this location in the search" → Drive letter:\USB_CRxxxx.
- ▶ If the USB driver is located in a hard disk directory (e.g. after an internet download), select the directory using the browser function in the dialogue window. Alternatively, enter the storage location directly.

 Only if the Windows installation wizard has found a valid driver file can you change to the next dialogue box with [Next].

 Windows carries out a "Windows logo test". The result of the system-internal test does not have any effect on the function of the software.

- ▶ Acknowledge the possible message "Windows logo test not passed" with [Continue].

- > The selected driver is displayed.
- > A message appears that installation was carried out correctly.

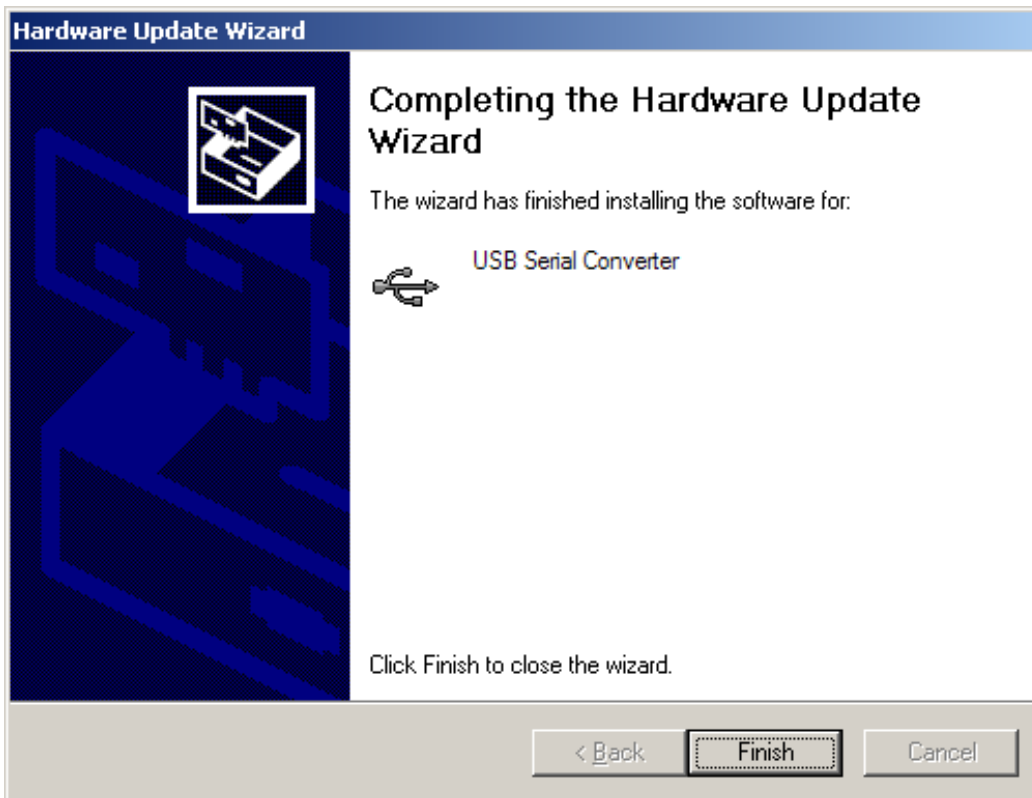

- ▶ Complete the installation with [Finish].

6.2.2 Install and define the virtual COM port

The installation is only necessary when started for the first time. The installation procedure is identical to the previous USB driver installation (→ 6.2.1).

The installation program automatically selects the next free COM port (e.g. COM3) for the driver.

- ▶ In case of conflicts with other programs, change the setting for the COM port in the Windows device manager.
 1. Open the device manager.
The service program device manager can for example be accessed via Start → Control Panel → Device Manager.
 2. Select the entry with a double click in the directory "Ports (COM & LPT)".
As an alternative: Right mouse click → Properties.
 3. Click on [Port settings] in the following dialogue box.
 4. Select [Advanced...] and redefine the COM port in the "Advanced Settings" menu (e.g. COM8), if necessary.



Do not use a COM port which is already used by another device. In most computers COM1 and COM2 are already assigned by the hardware interfaces.

- ▶ Confirm the setting with [OK].

- > The new COM port is indicated in the device manager following the driver name.

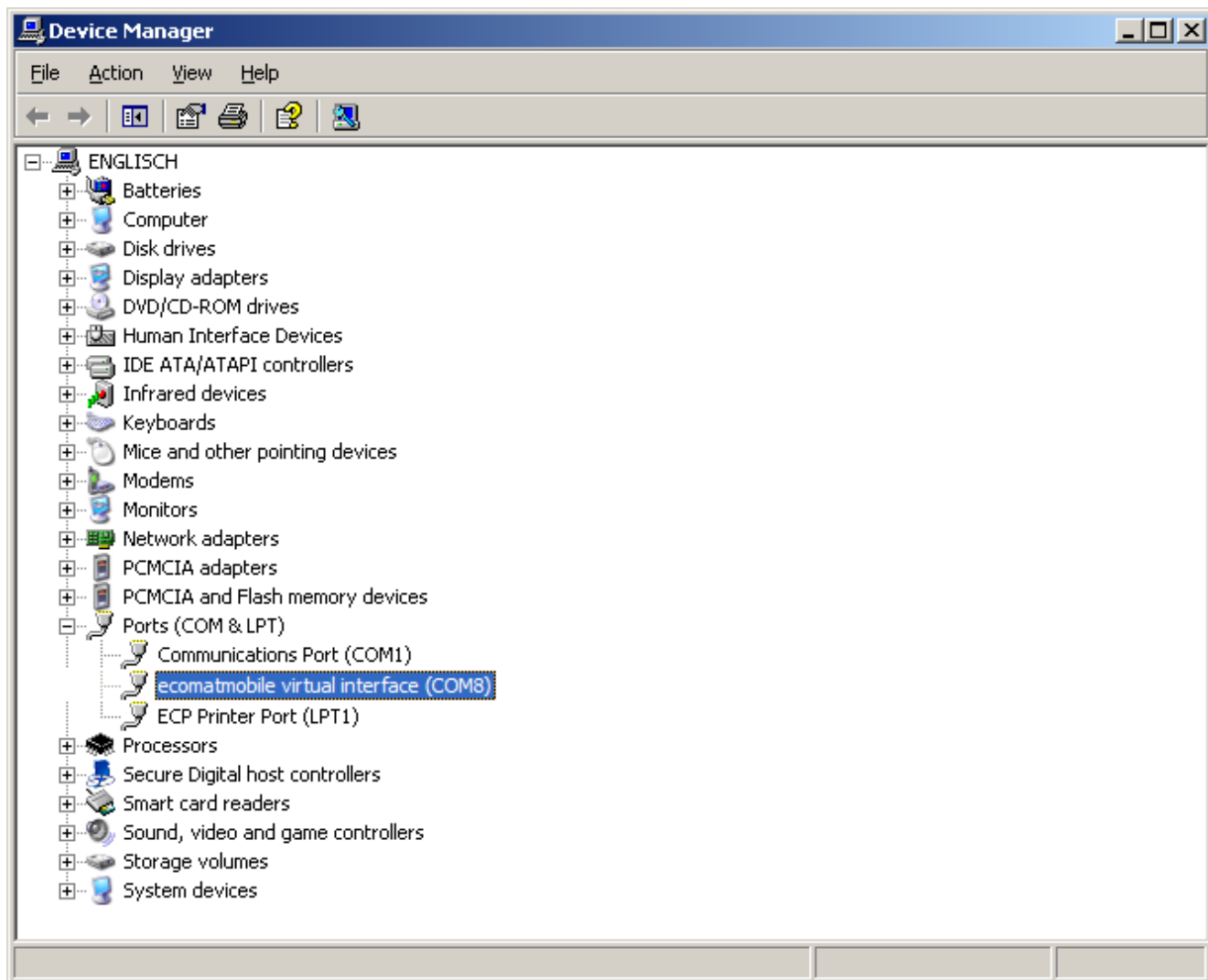

UK

6.3 Uninstall the drivers



If a driver is to be updated, the installed drivers have to be deinstalled first of all.

- ▶ Disconnect the USB connection between the controller and the PC.
- ▶ Open the service program "Software" via the start menu → Control Panel.
- ▶ Uninstall the drivers successively with [Change/Remove].

7 Technical data

7.1 Mechanical and electric data

CR7032
SafetyController
EN ISO 13849-1:2008 Category 3 PL d
IEC 62061:2005 SIL CL 2
32-bit processor
16 inputs / 16 outputs
2 CANsafety interfaces
CODESYS 2.3
8...32 V DC

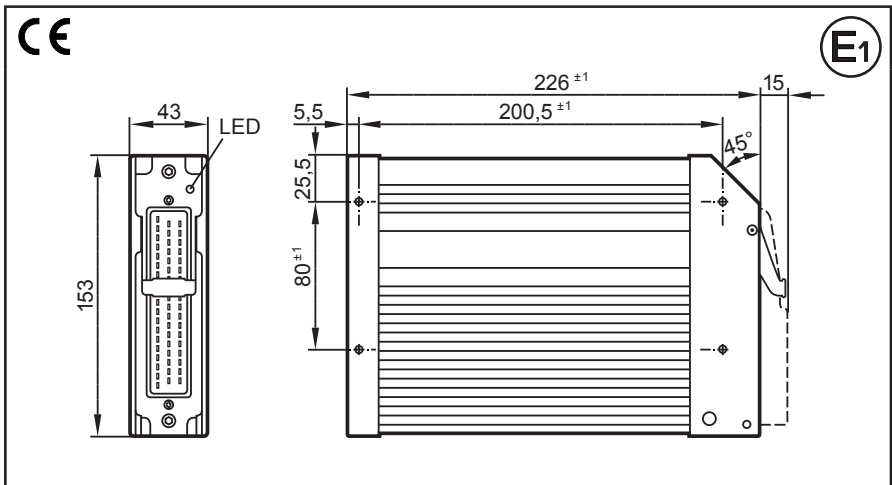

Technical data	Controller as black-box system to implement a central or decentralised system design
Mechanical data	
Housing	Closed, screened metal housing with flange fastening
Dimensions (H x W x D)	153 x 226 x 43 mm
Installation	Screw connection by means of 4 M5 x L screws to DIN 7500 or DIN 7984 Mounting position horizontal or vertical to the mounting wall
Connection	1 55-pin connector, latched, protected against reverse polarity, type AMP or Framatome AMP junior timer contacts, crimp connection 0.5/2.5 mm ²
Weight	1.2 kg
Housing/storage temperature	- 40...75 °C (depending on the load) / - 40...85 °C
Protection rating	IP 67 (for inserted connector with individually sealed cores, e.g. EC2084)
Electrical data	
Input/output channels	32 (16 inputs / 16 outputs)
Inputs	Configurable, safety-related Digital for positive/negative sensor signals, positive with diagnostic capabilities Analogue (0...10/32 V, 0...20 mA, ratiometric) Frequency (≤ 30 kHz)
Outputs	Configurable, safety-related Digital positive/negative switching (high/low side) PWM output (20...250 Hz, 8 x max. 4 A, 8 x max. 2 A) Current-controlled (8 x 0.01...2 A, 8 x 0.02...4 A)
Operating voltage	8...32 V DC
Overvoltage	36 V for t ≤ 10 s
Input voltage gradient	> 1.3 V/s
Reverse polarity protection	Yes
Current consumption	≤ 160 mA (without external load at 24 V DC)
CAN interfaces 1...4	CAN interface 2.0 A/B, ISO 11898
Baud rate	50 Kbits/s...1 Mbit/s (default 125 Kbits/s)
Communication profile	CANopen, CiA DS 301 version 4, CiA DS 401 version 1.4 or SAE J 1939 or free protocol or 2 x CANsafety for safe data transmission
Serial interface	RS-232 C
Baud rate	9.6...115.2 Kbit/s (default 115.2 Kbits/s)
Topology	Point-to-point (max. 2 participants); master-slave connection
Protocol	Predefined ifm protocol (INTELHEX)
Virtual COM port	USB, max. 1 MBaud
Processor	32-bit CPU Infineon TriCore 1796

CR7032
Device monitoring
Process monitoring concept
Physical memory
Memory allocation
Software/programming
Programming system
Display elements
Status indication
Operating states No longer valid if the colours and/or flashing modes are changed by the application program.

Technical data																							
Undervoltage/overvoltage monitoring Watchdog function (extended safety monitoring according to IEC 62061 and ISO 13849) Checksum test for program and system Excess temperature monitoring																							
Second switch-off mode for 8 outputs each via a relay (according to IEC 62061 and ISO 13849)																							
Flash: 4 Mbytes RAM: 2 Mbytes Remanent memory: 128 Kbytes																							
See system manual www.ifm.com → Data sheet search → CR7032 → More information																							
CODESYS version 2.3 (IEC 61131-3)																							
Three-colour LED (R/G/B)																							
<table border="1"> <thead> <tr> <th>LED colour</th> <th>Status</th> <th>Description</th> </tr> </thead> <tbody> <tr> <td>–</td> <td>Off</td> <td>No operating voltage</td> </tr> <tr> <td>Yellow</td> <td>1 x on</td> <td>Initialisation or reset checks</td> </tr> <tr> <td rowspan="3">Green</td> <td>5 Hz</td> <td>No operating system loaded</td> </tr> <tr> <td>2.0 Hz</td> <td>Run</td> </tr> <tr> <td>On</td> <td>Stop</td> </tr> <tr> <td rowspan="2">Red</td> <td>2.0 Hz</td> <td>Run with error</td> </tr> <tr> <td>on</td> <td>Fatal error or stop with error</td> </tr> </tbody> </table>			LED colour	Status	Description	–	Off	No operating voltage	Yellow	1 x on	Initialisation or reset checks	Green	5 Hz	No operating system loaded	2.0 Hz	Run	On	Stop	Red	2.0 Hz	Run with error	on	Fatal error or stop with error
LED colour	Status	Description																					
–	Off	No operating voltage																					
Yellow	1 x on	Initialisation or reset checks																					
Green	5 Hz	No operating system loaded																					
	2.0 Hz	Run																					
	On	Stop																					
Red	2.0 Hz	Run with error																					
	on	Fatal error or stop with error																					



7.2 Test standards and regulations

CR7032	Technical data	
Safety-related characteristics		
According to IEC 62061:2005	Safety Integrity Level Claim Limit	SIL CL 2
	Probability of Dangerous Failure per Hour	PFH _D 1.227 x 10 ⁻⁷
According to ISO 13849-1:2008	Performance Level	PL d
Test standards and regulations		
Electrical tests	EN 61000-6-2: 2005	Electromagnetic compatibility (EMC) Immunity
	EN 61000-6-4: 2007 +A1: 2011	Electromagnetic compatibility (EMC) Emission standard
	EN 61010: 2010	Safety requirements for electrical equipment for measurement, control and laboratory use
	UN/ECE-R10	Emission standard Immunity with 100 V/m
	ISO 7637-2: 2004	Pulse 1, severity level: IV; function state C Pulse 2a, severity level: IV; function state A Pulse 2b, severity level: IV; function state C Pulse 3a, severity level: IV; function state A Pulse 3b, severity level: IV; function state A Pulse 4, severity level: IV; function state A Pulse 5, severity level: III; function state C (data valid for the 24V system) Pulse 4, severity level: III; function state C (data valid for the 12 V system)
Climatic tests	EN 60068-2-30: 2006	Damp heat, cyclic upper temperature 55°C, number of cycles: 6
	EN 60068-2-78: 2002	Damp heat, steady state Test temperature 40°C / 93% RH, Test duration: 21 days
	EN 60068-2-52: 1996	Salt spray test Severity level 3 (vehicle)
Mechanical tests	ISO 16750-3: 2012	Test VII; Vibration, random mounting location: vehicle body
	EN 60068-2-6: 2008	Vibration, sinusoidal 10...500 Hz; 0.72 mm/10 g; 10 cycles/axis
	ISO 16750-3: 2012	Bumps 30 g/6 ms; 24,000 shocks

7.3 Input characteristics

CR7032	Input characteristics												
I00...I15	<table border="1"> <tr> <td>Resolution</td> <td>12 bits</td> </tr> <tr> <td>Accuracy</td> <td>$\pm 1\%$ FS (in the measuring range 0...20 mA: $\pm 2\%$ FS)</td> </tr> <tr> <td>Measuring ranges</td> <td>0...10 V, 0...32 V, 0...20 mA, ratiometric</td> </tr> </table>	Resolution	12 bits	Accuracy	$\pm 1\%$ FS (in the measuring range 0...20 mA: $\pm 2\%$ FS)	Measuring ranges	0...10 V, 0...32 V, 0...20 mA, ratiometric						
Resolution	12 bits												
Accuracy	$\pm 1\%$ FS (in the measuring range 0...20 mA: $\pm 2\%$ FS)												
Measuring ranges	0...10 V, 0...32 V, 0...20 mA, ratiometric												
Current input 0...20 mA (A)	<table border="1"> <tr> <td>Input resistance</td> <td>390 Ω</td> </tr> <tr> <td>Input frequency</td> <td>≤ 1 kHz (default 35 Hz)</td> </tr> </table>	Input resistance	390 Ω	Input frequency	≤ 1 kHz (default 35 Hz)								
Input resistance	390 Ω												
Input frequency	≤ 1 kHz (default 35 Hz)												
Voltage input 0...10 V (A)	<table border="1"> <tr> <td>Input resistance</td> <td>65.6 kΩ</td> </tr> <tr> <td>Input frequency</td> <td>≤ 1 kHz (default 35 Hz)</td> </tr> </table>	Input resistance	65.6 k Ω	Input frequency	≤ 1 kHz (default 35 Hz)								
Input resistance	65.6 k Ω												
Input frequency	≤ 1 kHz (default 35 Hz)												
Voltage input 0...32 V (A)	<table border="1"> <tr> <td>Input resistance</td> <td>50.7 kΩ</td> </tr> <tr> <td>Input frequency</td> <td>≤ 1 kHz (default 35 Hz)</td> </tr> </table>	Input resistance	50.7 k Ω	Input frequency	≤ 1 kHz (default 35 Hz)								
Input resistance	50.7 k Ω												
Input frequency	≤ 1 kHz (default 35 Hz)												
Voltage input ratiometric (A)	<table border="1"> <tr> <td>Input resistance</td> <td>50.7 kΩ</td> </tr> <tr> <td>Input frequency</td> <td>≤ 1 kHz (default 35 Hz)</td> </tr> </table>	Input resistance	50.7 k Ω	Input frequency	≤ 1 kHz (default 35 Hz)								
Input resistance	50.7 k Ω												
Input frequency	≤ 1 kHz (default 35 Hz)												
Frequency input (FRQ)	<table border="1"> <tr> <td>Input resistance</td> <td>3.2 kΩ</td> </tr> <tr> <td>Input frequency</td> <td>≤ 30 kHz</td> </tr> <tr> <td>Switch-on level</td> <td>$> 0.35 \dots 0.55 U_B$</td> </tr> <tr> <td>Switch-off level</td> <td>$< 0.29 U_B$</td> </tr> </table>	Input resistance	3.2 k Ω	Input frequency	≤ 30 kHz	Switch-on level	$> 0.35 \dots 0.55 U_B$	Switch-off level	$< 0.29 U_B$				
Input resistance	3.2 k Ω												
Input frequency	≤ 30 kHz												
Switch-on level	$> 0.35 \dots 0.55 U_B$												
Switch-off level	$< 0.29 U_B$												
Digital input (B _{UH})	<table border="1"> <tr> <td>Input resistance</td> <td>3.2 kΩ</td> </tr> <tr> <td>Input frequency</td> <td>≤ 50 Hz (default 35 Hz)</td> </tr> <tr> <td>Switch-on level</td> <td>$> 0.7 U_B (\pm 20\%)$</td> </tr> <tr> <td>Switch-off level</td> <td>$< 0.3 U_B (\pm 20\%)$</td> </tr> <tr> <td>Diagnosis wire break</td> <td>$> 0.95 U_B$</td> </tr> <tr> <td>Diagnosis short circuit</td> <td>< 1 V</td> </tr> </table>	Input resistance	3.2 k Ω	Input frequency	≤ 50 Hz (default 35 Hz)	Switch-on level	$> 0.7 U_B (\pm 20\%)$	Switch-off level	$< 0.3 U_B (\pm 20\%)$	Diagnosis wire break	$> 0.95 U_B$	Diagnosis short circuit	< 1 V
Input resistance	3.2 k Ω												
Input frequency	≤ 50 Hz (default 35 Hz)												
Switch-on level	$> 0.7 U_B (\pm 20\%)$												
Switch-off level	$< 0.3 U_B (\pm 20\%)$												
Diagnosis wire break	$> 0.95 U_B$												
Diagnosis short circuit	< 1 V												
Test input	<p>During the test mode (e.g. programming) the connector pin must be connected to VBB_s (8...32 V DC). For the "RUN" mode, connect the test input to GND.</p> <p>Observe the notes on the configuration of the inputs/outputs! ("SafetyController" system manual)</p>												

UK

7.4 Output characteristics

CR7032	Output characteristics												
Q00...Q15	<table border="1"> <tr> <td>Accuracy</td> <td>± 2 % FS (for inductive loads)</td> </tr> <tr> <td>Protective circuit for inductive loads</td> <td>integrated</td> </tr> <tr> <td>Diagnosis via current feedback</td> <td>Wire break/overload</td> </tr> <tr> <td>Diagnosis via voltage feedback</td> <td>Short circuit</td> </tr> </table>	Accuracy	± 2 % FS (for inductive loads)	Protective circuit for inductive loads	integrated	Diagnosis via current feedback	Wire break/overload	Diagnosis via voltage feedback	Short circuit				
Accuracy	± 2 % FS (for inductive loads)												
Protective circuit for inductive loads	integrated												
Diagnosis via current feedback	Wire break/overload												
Diagnosis via voltage feedback	Short circuit												
PWM output (PWM)	<table border="1"> <tr> <td>Output frequency</td> <td>20...250 Hz (per channel)</td> </tr> <tr> <td>Pulse/pause ratio</td> <td>1...1000 ‰</td> </tr> <tr> <td>Resolution</td> <td>1 ‰</td> </tr> <tr> <td>Switching current</td> <td>8 x 0.01...2 A 8 x 0.01...2 A / 0.02...4 A (4 of these outputs with H-bridge function)</td> </tr> </table>	Output frequency	20...250 Hz (per channel)	Pulse/pause ratio	1...1000 ‰	Resolution	1 ‰	Switching current	8 x 0.01...2 A 8 x 0.01...2 A / 0.02...4 A (4 of these outputs with H-bridge function)				
Output frequency	20...250 Hz (per channel)												
Pulse/pause ratio	1...1000 ‰												
Resolution	1 ‰												
Switching current	8 x 0.01...2 A 8 x 0.01...2 A / 0.02...4 A (4 of these outputs with H-bridge function)												
Digital output (B _H and B _{HL})	<table border="1"> <tr> <td>Switching voltage</td> <td>8...32 V DC</td> </tr> <tr> <td>Switching current</td> <td>8 x 0.01...2 A 8 x 0.02...4 A (4 of these outputs with H-bridge function)</td> </tr> </table>	Switching voltage	8...32 V DC	Switching current	8 x 0.01...2 A 8 x 0.02...4 A (4 of these outputs with H-bridge function)								
Switching voltage	8...32 V DC												
Switching current	8 x 0.01...2 A 8 x 0.02...4 A (4 of these outputs with H-bridge function)												
Current-controlled output (PWM _i)	<table border="1"> <tr> <td>H-bridge (channel pair)</td> <td>Q01 / Q03 Q09 / Q11</td> </tr> <tr> <td>Output frequency</td> <td>20...250 Hz (per channel)</td> </tr> <tr> <td>Control range</td> <td>8 x 0.01...2 A / 0.02...4 A 8 x 0.01...2 A</td> </tr> <tr> <td>Setting resolution</td> <td>1 mA</td> </tr> <tr> <td>Control resolution</td> <td>1 / 2 mA</td> </tr> <tr> <td>Load resistance</td> <td>≥ 3 Ω (at 12V DC) ≥ 6 Ω (at 24V DC)</td> </tr> </table>	H-bridge (channel pair)	Q01 / Q03 Q09 / Q11	Output frequency	20...250 Hz (per channel)	Control range	8 x 0.01...2 A / 0.02...4 A 8 x 0.01...2 A	Setting resolution	1 mA	Control resolution	1 / 2 mA	Load resistance	≥ 3 Ω (at 12V DC) ≥ 6 Ω (at 24V DC)
H-bridge (channel pair)	Q01 / Q03 Q09 / Q11												
Output frequency	20...250 Hz (per channel)												
Control range	8 x 0.01...2 A / 0.02...4 A 8 x 0.01...2 A												
Setting resolution	1 mA												
Control resolution	1 / 2 mA												
Load resistance	≥ 3 Ω (at 12V DC) ≥ 6 Ω (at 24V DC)												
Reference voltage V _{REF} OUT (sensor supply)	<p>For sensors and joysticks 5/10 V, 400 mA, accuracy ± 7 % Short-circuit proof and overload protected (10 V reference only from a supply voltage U_s ≥ 13 V)</p>												
Internal relays	<p>NO contacts for the second switch-off way of the outputs. In series of 8 semiconductor outputs each Forced control via the hardware and additional control via the user program.</p> <p>The relays must always be switched without load!</p> <table border="1"> <tr> <td>Switching current</td> <td>0.1...15 A</td> </tr> <tr> <td>Overload current</td> <td>20 A</td> </tr> <tr> <td>Number of operating cycles (without load)</td> <td>≥ 10⁶</td> </tr> <tr> <td>Switching time constant</td> <td>≤ 3 ms</td> </tr> </table>	Switching current	0.1...15 A	Overload current	20 A	Number of operating cycles (without load)	≥ 10 ⁶	Switching time constant	≤ 3 ms				
Switching current	0.1...15 A												
Overload current	20 A												
Number of operating cycles (without load)	≥ 10 ⁶												
Switching time constant	≤ 3 ms												
Load current per output group (VBB _R , VBB _O)	<p>≤ 12 A (for continuous operation ≤ 6 A; i.e. operation ≥ 10 min)</p>												
Overload protection (valid for all outputs)	<p>Max. 5 minutes (at 100% overload)</p>												
Short-circuit strength to GND	<p>Switch-off of the outputs via output diver and/or the runtime system</p>												

7.5 Wiring

CR7032

Technical data

Wiring

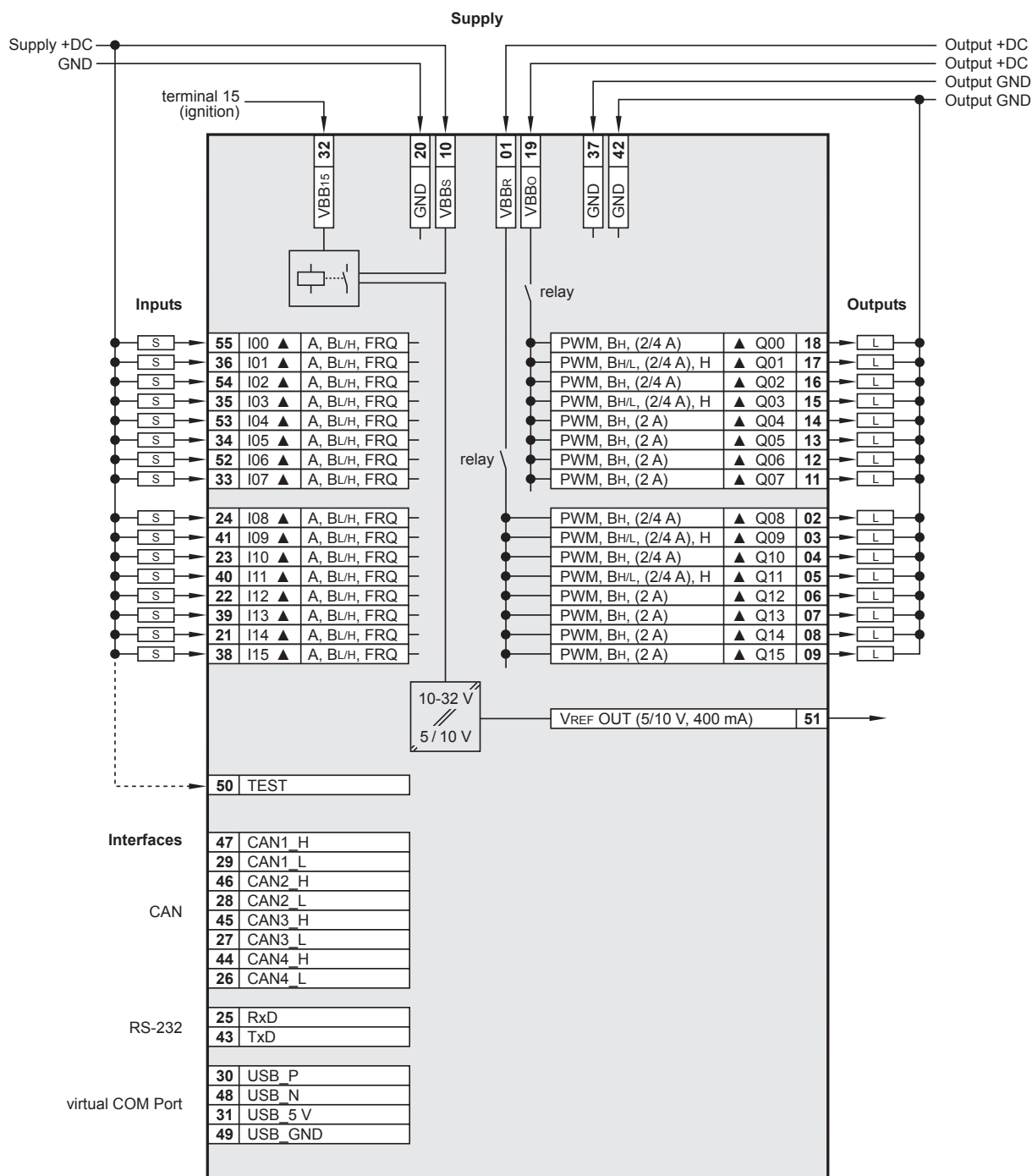

UK

Abbreviations

- A Analogue
- B_H Binary high side
- B_L Binary low side
- FRQ Frequency/pulse inputs
- H H-bridge function
- PWM Pulse width modulation
- VBB_S Supply sensors/module
- VBB_O Supply outputs
- VBB_R Supply via relay
- ▲ Safety-compatible input/output

8 Maintenance, repair and disposal

The unit is maintenance-free.

- ▶ Do not open the housing as the device does not contain any components which can be repaired by the user. The device must only be repaired by the manufacturer.
- ▶ Dispose of the device in accordance with the national environmental regulations.

9 Approvals/standards

Test standards and regulations (→ 7 Technical data)

The EC declaration of conformity and approvals can be found at:
www.ifm.com