

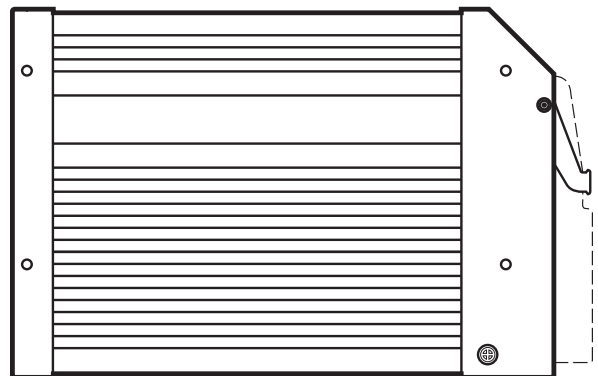

Original operating instructions
SafetyController

CR7506

UK



Bestimmungsgemäße Verwendung

Die freiprogrammierbaren Steuerungen der Baureihe "SafetyController" sind für den Einsatz unter erschwerten Bedingungen ausgelegt. Sie sind geeignet zum direkten Einbau in Fahrzeugen und mobilen Arbeitsmaschinen unter Verwendung des Bordnetzes (12/24 V DC Batteriebetrieb).

Zusätzlich sind in den durch diese Anleitung beschriebenen Steuerungen für sicherheitsrelevante Aufgaben spezielle Hard- und Softwarefunktionen integriert, die einen Einsatz als Sicherheitssteuerung ermöglichen.

DE

⚠️ WARNUNG

Die Steuerungen "SafetyController" sind für sicherheitsrelevante Aufgaben im Sinne des Personenschutzes zugelassen, wenn die entsprechenden Systemprüfroutinen in das Betriebssystem und die Applikationssoftware eingebunden werden und durch einen vollständigen Funktionstest geprüft wurden.

Die endgültige Einstufung und Freigabe eines Systems (Hard- und Software) darf aber nur durch die entsprechenden Überwachungsorganisationen erfolgen.

Programmierung und wesentliche Ergänzungen zu dieser Anleitung

Neben dem Programmiersystem CODESYS und dem Softwaretool "Downloader" werden zur Inbetriebnahme und Programmierung der Steuerung folgende Dokumente benötigt:

- "Wichtige Hinweise zum CR7n32" für die von Ihnen verwendeten Softwarestände
- Systemhandbuch "SafetyController"
- Programmierhandbuch "CODESYS"

Sollten Ihnen diese Dokumente nicht vorliegen, können Sie diese in Deutsch oder Englisch auf der angegebenen Homepage per Internet oder unter der unten angegebenen Anschrift, per E-Mail, per Telefax, per Telefon oder per Post unentgeltlich anfordern.

Internet	www.ifm.com/de Datenblattsuche → Art.-Nr. → weitere Informationen
Anschrift	ifm electronic gmbh • Friedrichstraße 1 • 45128 Essen
E-Mail	info@ifm.com
Telefax	0800 16 16 16 5 (kostenlose Fax-Hotline)
Telefon	0800 16 16 16 4 (kostenlose Service-Hotline)

Inbetriebnahme

Das Gerät darf nur durch fachkundiges Personal in Betrieb genommen werden.

Wir weisen zudem ausdrücklich darauf hin, dass jegliche Haftung ausgeschlossen ist, wenn die entsprechenden Hinweise in den Dokumentationen für die Inbetriebnahme und Programmierung nicht beachtet werden.

Functions and features

The programmable controllers of the series "SafetyController" are designed for use in safety-related applications. They are suitable for direct installation in vehicles and mobile machines using the on-board system (12/24 V DC battery operation).

Special hardware and software functions are integrated into the controllers for safety-related applications, as described in these instructions. This enables the use as a safety controller.

⚠ WARNING

The "SafetyController" devices are approved for safety-related tasks in the field of operator protection, if the corresponding system check routines are integrated in the operating system and the application software and have been checked by a complete function test. However, the final classification and approval of a system (hardware and software) may only be carried out by the corresponding supervisory organisations.

UK

Programming and important additions to these instructions

In addition to the programming system CODESYS and the software tool "Downloader", the following documents are required for programming and commissioning of the controller:

- "Important notes on CR7n32" for the software versions used by you
- System manual "SafetyController"
- Programming manual "CODESYS"

If you do not have these documents, you can request them in German or English free of charge on the indicated website or via e-mail, fax, phone or post at the address stated below.

Internet	www.ifm.com/uk
	Data sheet search → Order no. → More information
Address	ifm electronic ltd. efactor House • Kingsway Business Park • Oldfield Road Hampton • Middlesex TW12 2HD
E-mail	enquiry_gb@ifm.com
Fax	020 8213-0001
Telephone	020 8213-0000

Set-up

Only qualified staff is allowed to set up the device.

Furthermore we expressly point out that any liability is excluded if the notes in the programming and set-up documents are not adhered to.

Fonctionnement et caractéristiques

Les systèmes de contrôle-commande programmables de la série " SafetyController " sont conçus pour l'emploi dans des conditions sévères.

Ils sont appropriés pour l'installation directe dans des véhicules et des engins mobiles en utilisant le système à bord (batterie 12/24 V DC).

De plus, des fonctions matériel et logiciel spécifiques sont intégrées dans les systèmes de contrôle-commande pour des applications de sécurité et décrites dans cette notice permettant un emploi comme système de contrôle-commande de sécurité.

⚠ AVERTISSEMENT

Les automates programmables " SafetyController " sont homologués pour des tâches de sécurité dans le sens de la protection des personnes si les routines systèmes correspondantes sont intégrées dans le système d'exploitation et le logiciel d'application et ont été testées à l'aide d'un test fonctionnel complet.

Cependant, la classification définitive et l'homologation d'un système (matériel et logiciel) ne doivent être effectuées que par les organismes de contrôle correspondants.

FR

Programmation et ajouts importants à cette notice

Outre le système de programmation CODESYS et l'outil logiciel " downloader ", les documents suivants sont nécessaires pour la mise en service et la programmation du système contrôle-commande :

- " Remarques importantes pour CR7n32 " pour les versions du logiciel que vous utilisez
- Manuel du système " SafetyController "
- Manuel de programmation " CODESYS "

Si vous n'avez pas ces documents, vous pouvez les demander en allemand ou anglais gratuitement sur le site web indiqué ou par e-mail, fax, téléphone ou courrier à l'adresse indiquée.

Internet	www.ifm.com/fr
	Fiche technique → N° de commande → Plus de détail
Adresse	ifm electronic - Agence Paris • Immeuble Uranus • 1-3 rue Jean Richepin 93192 NOISY LE GRAND CEDEX
E-mail	info.fr@ifm.com
Fax	0820 22 22 04
Téléphone	0820 22 30 01

Mise en service

L'appareil ne doit être mis en service que par un personnel compétent.

De plus, nous signalons expressément que toute responsabilité est exclue si les remarques correspondantes dans les documents de programmation et de mise en service ne sont pas respectées.

Uso conforme

I sistemi di controllo programmabili della serie "SafetyController" sono concepiti per l'uso in condizioni difficili. Sono adatti per il montaggio diretto in veicoli e macchine mobili utilizzando l'impianto elettrico di bordo (con batteria 12/24 V DC).

Inoltre speciali funzioni hardware e software sono integrate nei sistemi di controllo per applicazioni di sicurezza, descritti nel presente manuale, permettendone un impiego come sistemi di controllo di sicurezza.

! ATTENZIONE

I sistemi di controllo "SafetyController" sono omologati per applicazioni di sicurezza rivolte alla protezione di persone se le corrispondenti verifiche di routine del sistema vengono integrate nel sistema operativo e nel software applicativo e sono state controllate mediante un test funzione completo.

Tuttavia la classificazione definitiva e l'omologazione di un sistema (hardware e software) devono essere eseguite soltanto tramite gli enti di controllo corrispondenti.

IT

Programmazione e supplementi rilevanti per questo manuale

Oltre al sistema di programmazione CODESYS e al software "Downloader" sono necessari i seguenti documenti per la messa in funzione e la programmazione del sistema di controllo:

- "Indicazioni importanti relative al CR7n32" per le versioni software utilizzate
- manuale del sistema "SafetyController"
- manuale di programmazione "CODESYS"

Se non si possiede questa documentazione, è possibile richiederla gratuitamente in tedesco o in inglese sul sito web indicato oppure per posta all'indirizzo di cui sotto, per e-mail, per fax o per telefono.

Internet	www.ifm.com/it
	Scheda tecnica → N. d'ordine → Informazione sul prodotto
Indirizzo	ifm electronic srl • Centro Dir. Colleoni • Andromeda 2 • Via Paracelso No. 18 20041 Agrate Brianza (MB)
E-Mail	info.it@ifm.com
Telefax	039 689 99 95
Telefono	039 689 99 82

Messa in funzione

Il sistema deve essere messo in funzione soltanto da personale esperto.

Facciamo espressamente presente che si declina ogni responsabilità qualora non vengano rispettate le indicazioni corrispondenti nella documentazione per la programmazione e la messa in funzione.

Utilización correcta

Los controladores programables de la gama "SafetyController" están concebidos para su utilización bajo condiciones difíciles. Son aptos para una instalación directa en vehículos y máquinas móviles utilizando la red de a bordo (funcionamiento con batería de 12/24 V DC). En los controladores para aplicaciones de seguridad descritos en estas instrucciones también están integradas funciones especiales de hardware y software, las cuales posibilitan la utilización como controlador de seguridad.

⚠ ADVERTENCIA

Los controladores "SafetyController" están homologados para aplicaciones de seguridad relativas a la protección de personas, siempre y cuando las rutinas de verificación del sistema estén integradas en el sistema operativo y en el software de aplicación y sean examinadas mediante un test completo de funcionamiento. Sin embargo, la clasificación definitiva y la autorización de un sistema (hardware y software) solamente puede llevarse a cabo a través de los correspondientes organismos de control.

ES

Programación y suplementos fundamentales de estas instrucciones

Además del sistema de programación CODESYS y de la herramienta "Downloader", para la puesta en marcha y programación del controlador son necesarios los siguientes documentos:

- "Indicaciones importantes sobre el CR7n32" para las versiones de software que usted utiliza
- Manual del sistema "SafetyController"
- Manual de programación "CODESYS"

En caso de que usted no disponga de esta documentación, puede solicitarla de forma gratuita en los idiomas alemán e inglés a través de los medios que se indican a continuación: página web, correo electrónico, fax, teléfono o dirección postal.

Internet	www.ifm.com/es Ficha técnica → N° de pedido → Información sobre productos
Dirección	ifm electronic s.a. • Edificio Prima Muntadas A • Parc Mas Blau • C/Berguedà 1 08820 El Prat de Llobregat
E-mail	info.es@ifm.com
Fax:	(+ 34) 93.479.30.86
Teléfono	(+ 34) 93.479.30.80

Puesta en marcha

El equipo solo puede ser puesto en marcha por personal especializado. Advertimos expresamente de que queda excluida toda responsabilidad en caso de que no se observen las correspondientes indicaciones descritas en la documentación de programación y puesta en marcha.

Utilização adequada

Os controladores livremente programáveis da série "SafetyController" destinam-se à utilização em condições difíceis. Eles são adequados para a montagem direta em veículos e máquinas móveis usando a rede elétrica própria (operação com bateria 12/24 V DC). Além disso, os controladores destinados a tarefas de segurança, descritos no presente manual, integram funções especiais de hardware e software, que permitem a sua utilização como controladores de segurança.

⚠ AVISO

Os controladores "SafetyController" estão aprovados para tarefas no campo da segurança de pessoas, se as respectivas rotinas de controlo do sistema forem incluídas no sistema operativo e no software de aplicação e se tiverem sido submetidos a um teste completo de funcionamento. Contudo, a classificação final e a homologação do sistema (hardware e software) apenas podem ser efectuadas pelas respectivas entidades de controlo.

Programação e complementos essenciais deste manual

Além do sistema de programação CODESYS e a ferramenta de software "Downloader" são necessários os seguintes documentos para a colocação em funcionamento e a programação do controlador:

- "Avisos importantes sobre o CR7n32" para as versões de software que você usa
- Manual de sistema "SafetyController" (controlador de segurança)
- Manual de programação "CODESYS"

Caso não disponha desta documentação, é possível solicitá-la gratuitamente em língua alemã ou inglesa através da página de Internet ou dos seguintes endereços e contactos de email, telefax, telefone e correio:

Internet	www.ifm.com/pt
	Ficha técnica → no. do pedido → outros dados
Endereço	ifm electronic sucursal em Portugal • Avenida da República 2503 Sala 324430-208 Vila Nova de Gaia
E-Mail	info.pt@ifm.com
Fax	0223 71 71 10
Telefone	0223 71 71 08

Colocação em funcionamento

O produto só deve ser colocado em funcionamento por pessoal especializado. Chamamos ainda expressamente à atenção que não assumimos quaisquer responsabilidades em casos de falta de incumprimento das indicações da documentação relativas à programação e colocação em funcionamento.

Gebruik volgens de voorschriften

De vrij te programmeren besturingen van de bouwserie "SafetyController" zijn ontworpen voor gebruik onder zware omstandigheden. Ze zijn direct te plaatsen in voertuigen of mobiele installaties die gebruik maken van een on-board systeem (12/24 V DC accu systemen).

Bovendien zijn in de in deze handleiding beschreven besturingen, voor taken die relevant zijn voor de veiligheid, speciale hard- en softwarefuncties geïntegreerd. Deze functies maken een gebruik als veiligheidsbesturing mogelijk.

⚠ WAARSCHUWING

De besturingen onder de naam "SafetyController" zijn toegelaten voor taken die relevant zijn voor de veiligheid, in de zin van bescherming van personen, wanneer de betreffende systeemtestfuncties in het besturingssysteem en de applicatiesoftware geïntegreerd worden en door een volledige functietest gecontroleerd zijn.

De definitieve classificatie en de vrijgave van het systeem (hard- en software) mogen echter alleen geschieden door de desbetreffende keuringsinstanties.

Programmering en belangrijke aanvullingen op deze handleiding

NL

Als toevoeging op de programmeer omgeving CODESYS en software tool "downloader", zijn de volgende documenten nodig om de controller te programmeren en te autoriseren:

- Belangrijke mededelingen betreffende de CR7n32 voor de door u toegepaste software versies.
- Systeemhandboek "SafetyController"
- Programmeerhandboek "CODESYS"

Zijn deze documenten niet aanwezig, dan kunt u deze in het Duits of Engels op de aangegeven internetpagina of op het hieronder aangegeven adres per e-mail, fax, telefoon of post gratis aanvragen.

Internet	www.ifm.com/nl
	Datablad → Bestelnummer → Aanvullende informatie
Adres	ifm electronic b.v. • Deventerweg 1 E • 3843 GA HARDERWIJK
E-mail	info.nl@ifm.com
Fax	0341 - 438 430
Telefoon	0341 - 438 438

Inbedrijfstelling

Het product mag uitsluitend door deskundig personeel in gebruik genomen worden. Wij wijzen er bovendien uitdrukkelijk op, dat elke aansprakelijkheid uitgesloten is wanneer de desbetreffende aanwijzingen in de documenten voor de programmering en inbedrijfstelling niet in acht genomen worden.

Brug i overensstemmelse med formålet

De frit programmérbare styringer i serien "SafetyController" er konstrueret til brug under vanskelige forhold. De er velegnede til direkte montering i køretøjer og mobile maskine. Maskinens eksisterende strømforsyning må benyttes (12/24 V DC batteridrift).

Til sikkerhedsrelevante opgaver er der i de styringer, der beskrives i denne vejledning, derudover integreret specielle hard- og softwarefunktioner, der muliggør en brug som sikkerhedsstyring.

⚠ ADVARSEL

Styringerne "SafetyController" er godkendt til sikkerhedsrelevante opgaver i henhold til personsikkerhed, hvis de tilsvarende systemkontrolrutiner integreres i operativsystemet og applikationssoftwaren samt afprøves med en komplet funktionstest.

Den endelige klassificering og frigivelse af systemet (hard- og software) må dog kun foretages af de pågældende kontrolorganisationer.

Programmering og væsentlige supplementer til denne vejledning

Ud over programmerings systemet CODESYS og software-værktøjet "downloader," kræves der følgende dokumenter for programmering og idriftsættelse af controlleren:

- "Vigtige oplysninger vedrørende CR7n32" i forbindelse med de software-versioner du anvender
- Systemhåndbog "SafetyController"
- Programmeringshåndbog "CODESYS"

Hvis disse dokumentationer ikke foreligger, kan de bestilles gratis på tysk eller engelsk via internet på den anførte hjemmeside eller via e-mail, telefax, telefon eller post på følgende adresse.

Internet	www.ifm.com/dk
	ifm datablad direkte → bestil. nr. → Mere
Adresse	ifm electronic a/s • Ringager 4A, 1.sal tv. • DK-2605 Brøndby
E-mail	info.dk@ifm.com
Fax	70 20 11 09
Telefon	70 20 11 08

Ibrugtagning

Udstyret må kun tages i brug af fagkyndigt personale.

Vi gør derudover udtrykkeligt opmærksom på, at vi fralægger os ethvert ansvar, hvis de pågældende henvisninger i dokumentationen ikke overholdes ved programmeringen og ibrugtagningen.

Toiminnot ja ominaisuudet

"SafetyController" -laitesarjan vapaasti ohjelmoitavat ohjausjärjestelmät on suunniteltu käytettäväksi vaativissa olosuhteissa. Ne voidaan asentaa suoraan ajoneuvoihin ja liikkuviin työkoneisiin, joissa on 12/24 V DC sähköjärjestelmä (akkukäyttö).

Lisäksi tässä ohjeessa kuvattuihin turvallisuuteen liittyviin sovellutuksiin tarkoitettuihin ohjausjärjestelmiin on integroitu erityisiä laitteisto- ja ohjelmistotoimintoja, jotka mahdollistavat käytön turvaohjausjärjestelmänä.

⚠ VAROITUS

"SafetyController"-ohjausjärjestelmät on hyväksytty käytettäväksi turvallisuuden kannalta tärkeissä henkilösuojaustehtävissä, jos vastaavat järjestelmän tarkastusrutiinit on integroitu käyttöjärjestelmään ja sovellutusohjelmisto on läpäissyt täydellisen toimintatestin. Järjestelmän (laitteisto ja ohjelmisto) lopullisen luokituksen ja hyväksymisen saavat kuitenkin suorittaa ainoastaan vastaavat tarkastusorganisaatiot.

Ohjelmointi ja tärkeitä lisäyksiä näihin käyttöohjeisiin

CODESYS-ohjelmointijärjestelmän ja "downloader"-lataustyökalun lisäksi controllerin ohjelmoinnissa ja käyttöönotossa tarvitaan seuraavat dokumentit:

- "Tärkeitä huomautuksia laitteelle CR7n32" koskien käyttämiäsi ohjelmistoversioita
- Järjestelmäkäsikirja "SafetyController"
- Ohjelmointikäsikirja "CODESYS"

Jollei sinulla ole näitä dokumentteja, voit tilata ne veloitusetta saksan- tai englanninkielisenä alla ilmoitetulta web-sivustolta tai sähköpostilla, faksilla tai puhelimitse alla mainitusta osoitteesta.

FI

Internet	www.ifm.com/fi Data sheet direct → Tilausnumero → Lisätietoja
Osoite	ifm electronic oy • Vaakatie 5 • 00440 Helsinki
Sähköposti	info.fi@ifm.com
Faksi	+358 (0)75 329 5010
Puhelin	+358 (0)75 329 5000

Käyttöönotto

Laitteen käyttöönoton saa suorittaa ainoastaan turvateknisen koulutuksen saanut henkilö. Haluamme lisäksi korostaa, että ohjelmointi- ja käyttöönottodokumenttien ohjeiden noudattamatta jättäminen johtaa kaikkien takuiden ja vastuiden raukeamiseen.

Funktion och egenskaper

Programmerbara controllers i produktserien "SafetyController" är konstruerade för användning i tuffa förhållanden. De är lämpliga för att installeras i fordon och på mobila maskiner direkt mot maskinens interna elsystem (12/24 V DC).

Controllers för säkerhetsrelaterade applikationer, som beskrivs i denna anvisning, har särskilt integrerade hård- och mjukvarufunktioner som möjliggör deras användning som säkerhetscontroller.

⚠ VARNING

"SafetyController"-enheterna är godkända för säkerhetsrelaterade uppgifter inom området personskydd om de relevanta systemkontrollrutinerna integreras i operativsystemet och applikationsmjukvaran, och dessa har kontrollerats genom en fullständig funktionstest. Slutgiltig klassificering och godkännande av ett system (hårdvara och mjukvara) får dock endast utfärdas av relevanta övervakningsorganisationer.

Programmering och viktiga tillägg till dessa instruktioner

Utöver utvecklingsmiljön CODESYS och programvaran "downloader", behövs följande dokument för programmering och handhavande av controllern:

- "Viktiga anvisningar för CR7n32" gällande de programversioner som används av dig
- Systemhandbok "SafetyController"
- Programmeringshandbok "CODESYS"

Skulle dessa dokument inte finnas till hands, kan de beställas utan kostnad på engelska eller tyska från den angivna hemsidan eller via e-mail, fax, telefon eller per post från nedanstående angivna adresser.

Internet	www.ifm.com/se
	Datablad direkt → Best.nr. → Ytterligare data
Adress	ifm electronic ab • Hallavägen 10 512 60 Överlida
e-post	info.se@ifm.com
Fax	0325-66 15 90
Telefon	0325-66 15 00

SE

Installation

Enheten får endast tas i drift av kvalificerad personal.

Dessutom vill vi uttryckligen påpeka att vi frånsäger oss allt ansvar om instruktionerna som ges i dokumentationen för programmering och driftsättning ej beaktas.

Λειτουργία και χαρακτηριστικά

Οι προγραμματιζόμενοι ελεγκτές σειράς "SafetyController" έχουν σχεδιαστεί για χρήση σε αντίξοες συνθήκες. Είναι κατάλληλα για άμεση τοποθέτηση σε οχήματα και κινούμενες μηχανές, χρησιμοποιώντας την πλακέτα συστήματος (12/24 V DC λειτουργία μπαταρίας). Ειδικές λειτουργίες υλικού και λογισμικού είναι επιπρόσθετα ενσωματωμένες στους ελεγκτές για εφαρμογές ασφαλείας και περιγράφονται σε αυτές τις οδηγίες που επιτρέπουν τη χρήση ως ελεγκτή ασφαλείας.

⚠ ΠΡΟΕΙΔΟΠΟΙΗΣΗ

Οι συσκευές "SafetyController" εγκρίνονται για εργασίες ασφαλείας στον τομέα της προστασίας χειριστών εάν οι αντίστοιχες ρουτίνες ελέγχου συστημάτων είναι ενσωματωμένες στο λειτουργικό σύστημα και τα προγράμματα εφαρμογών και έχουν ελεγχθεί από μια πλήρη δοκιμή λειτουργίας.

Εντούτοις, η τελική ταξινόμηση και η έγκριση ενός συστήματος (υλικό και λογισμικό) μπορούν να πραγματοποιηθούν μόνο από τις αντίστοιχες εποπτικές οργανώσεις.

Προγραμματισμός και σημαντικές προσθήκες σε αυτές τις οδηγίες

Επιπρόσθετα από το σύστημα προγραμματισμού CODESYS και το εργαλείο λογισμικού "downloader", απαιτούνται και τα ακόλουθα έγγραφα για τον προγραμματισμό και την έναρξη λειτουργίας του ελεγκτή:

- "Σημαντικές σημειώσεις σχετικά με το CR7n32 ", για τις εκδόσεις λογισμικού που χρησιμοποιείται από εσάς
- Εγχειρίδιο συστήματος "SafetyController"
- Εγχειρίδιο προγραμματισμού "CODESYS"

Εάν δεν έχετε αυτά τα έγγραφα, μπορείτε να τα ζητήσετε στα Γερμανικά ή Αγγλικά δωρεάν στον υποδειγμένο ιστοχώρο ή μέσω ηλεκτρονικού ταχυδρομείου, φαξ, τηλεφώνου ή στην κάτωθι διεύθυνση.

GR

Διαδίκτυο	www.ifm.com/gr Αναζήτηση τεχνικού φυλλαδίου → Κωδικός παραγγελίας → Άλλες πληροφορίες
Διεύθυνση	ifm electronic Μονοπρόσωπη ΕΠΕ • Τ.Θ. 61407 • 151 06 Αμαρούσιο - The Mall
E-Mail:	info.gr@ifm.com
Φαξ:	210 61 99 400
Τηλέφωνο:	210 61 80 090

Προετοιμασία για λειτουργία

Μόνο εξειδικευμένο προσωπικό επιτρέπεται να ρυθμίσει τη συσκευή.

Επιπλέον ρητώς επισημαίνουμε ότι οποιαδήποτε ευθύνη αποκλείεται εάν δεν υιοθετούνται οι σημειώσεις στα έγγραφα προγραμματισμού και οργάνωσης.

Contents

1	Preliminary note	3
1.1	Symbols used	3
1.2	Warning signs used	3
2	Safety instructions	4
2.1	In general	4
2.2	Target group	4
2.3	Electrical connection	4
2.4	Housing temperature	4
2.5	Tampering with the device	5
2.6	Electromagnetic compatibility	5
3	Installation	6
3.1	Fixing	6
3.2	Mounting position	6
3.3	Mounting surface	7
3.4	Heat dissipation	7
4	Electrical connection	8
4.1	Wiring	8
4.2	Ground connection	8
4.3	Fuses	8
4.4	Laying the supply and signal cables	8
4.5	Interaction between inputs/outputs in an output group	9
5	Technical data	10
6	Maintenance, repair and disposal	17
7	Approvals/standards	17

This document is the original instructions.

Licences and trademarks

Microsoft®, Windows®, Windows XP® and Windows Vista® are registered trademarks of Microsoft Corporation. All trademarks and company names are subject to the copyright of the respective companies.

1 Preliminary note

This document applies to devices of the type "SafetyController" (art. no.: CR7506).



Observe the preceding notes on use as prescribed, programming and set-up of controllers of the series "SafetyController".

Read this document before use to familiarise yourself with operating conditions, installation and operation. Keep this document during the entire duration of use of the device.

Adhere to the safety instructions.

UK

1.1 Symbols used

- ▶ Instruction
- > Reaction, result
- [...] Designation of pushbuttons, buttons or indications
- Cross-reference
-  Important note
Non-compliance can result in malfunctions or interference.
-  Information
Supplementary note

1.2 Warning signs used

WARNING

Warning of serious personal injury.
Death or serious irreversible injuries may result.

CAUTION

Warning of personal injury.
Slight reversible injuries may result.

NOTE

Warning of damage to property.

2 Safety instructions

2.1 In general

These instructions are part of the device. It contains information and illustrations about the correct handling of the device and must be read before installation or use.

Observe the operating instructions. Non-observance of the instructions, operation which is not in accordance with use as prescribed below, wrong installation or incorrect handling can seriously affect the safety of operators and machinery.

2.2 Target group

These instructions are intended for specialists. These specialists are people who are qualified by their appropriate training and their experience to see risks and to avoid possible hazards that may be caused during operation or maintenance of the device.

2.3 Electrical connection

Disconnect the device externally before handling it. If necessary, also disconnect any independently supplied output load circuits.

If the device is not supplied by the mobile on-board system (12/24 V battery operation), it must be ensured that the external voltage is generated and supplied according to the criteria for safety extra-low voltage (SELV) as this voltage is supplied without further measures to the connected controller, the sensors and the actuators.

The wiring of all signals in connection with the SELV circuit of the device must also comply with the SELV criteria (safety extra-low voltage, safe electrical isolation from other electric circuits).

If the supplied SELV voltage is externally grounded (SELV becomes PELV), the responsibility lies with the user and the respective national installation regulations must be complied with. All statements in this document refer to the device the SELV voltage of which is not grounded.

The connection terminals may only be supplied with the signals indicated in the technical data and/or on the device label and only the approved accessories of ifm electronic may be connected.

2.4 Housing temperature

According to the technical specifications below the device can be operated in a wide ambient temperature range. Because of the additional internal heating the housing walls can have high perceptible temperatures when touched in hot environments.

2.5 Tampering with the device

In case of malfunctions or uncertainties please contact the manufacturer. Tampering with the device can seriously affect the safety of operators and machinery. It is not permitted and leads to the exclusion of any liability and warranty claims.

2.6 Electromagnetic compatibility

This is a class A installation. It can cause radio interference in domestic areas. In this case the operator is requested to take appropriate measures.

UK

3 Installation

3.1 Fixing

- ▶ Fix the controller to a flat surface using 4 M5 screws.
Screw material: steel or stainless steel
Tightening torque: 8 \pm 2 Nm

NOTE

Use screws with a low head to avoid that the connector is damaged when placed and locked.

Screws to be used (examples)	Standard
Button head hexagon socket screws (M5 x L)	ISO 7380
Cylinder screws with hexagon socket and low head (M5 x L)	DIN 7984
Cutting screws for metric ISO thread with low head	DIN 7500

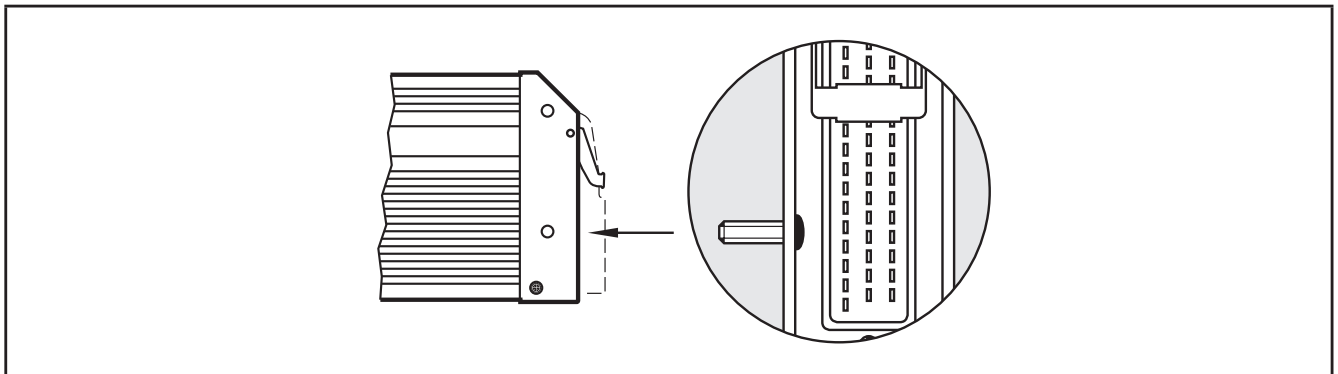

Example button head hexagon socket screw

3.2 Mounting position

- ▶ Align the controller in such a way that the cable entry of the connector faces downwards.

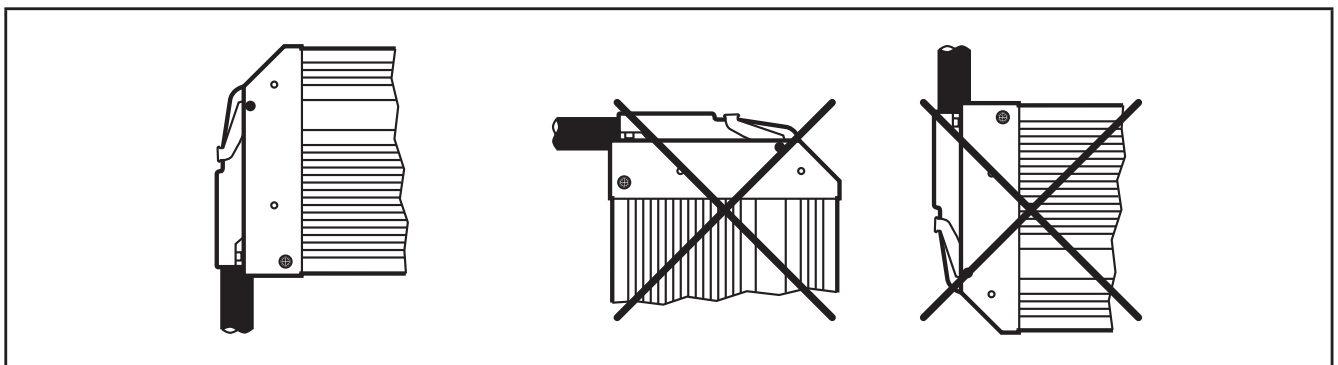

Preferred mounting position

3.3 Mounting surface

- ▶ Use compensating elements if there is no flat mounting surface available.

NOTE

The housing must not be exposed to any torsional forces or mechanical stress.

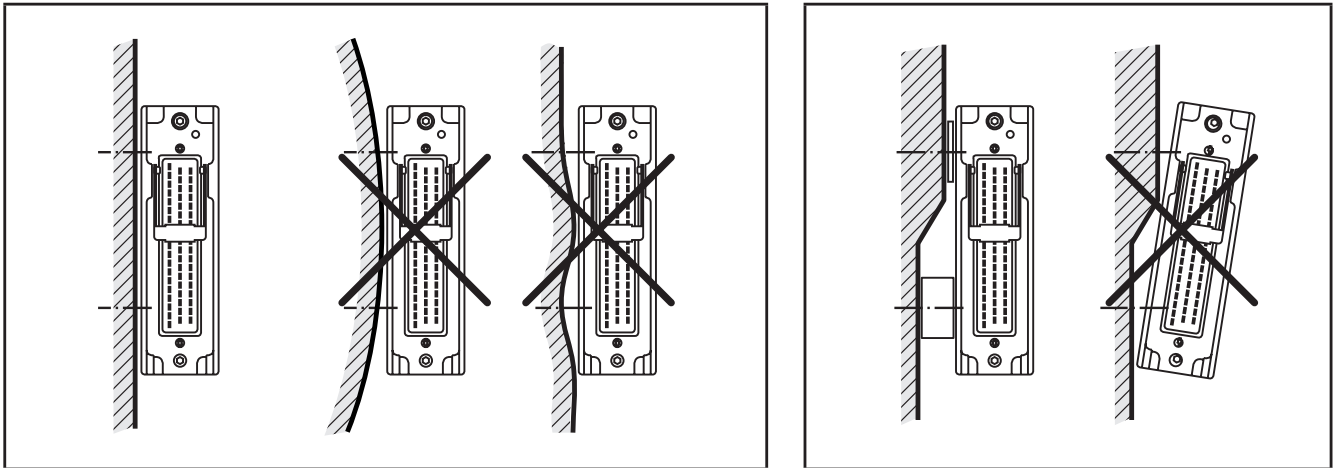

Mounting surface

3.4 Heat dissipation

- ▶ Ensure sufficient heat dissipation as the internal heating of the electronics is conducted away via the housing.
- ▶ In case of sandwich mounting of controllers use spacers.

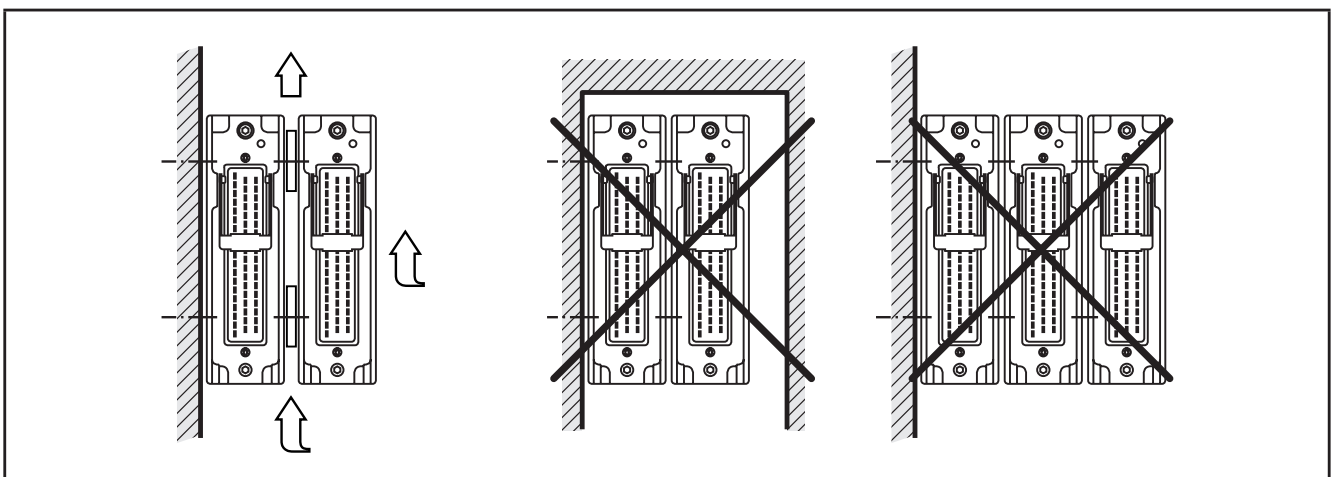

Heat dissipation and sandwich mounting

UK

4 Electrical connection

4.1 Wiring

Pin connection (→ 5 Technical data)



If a prewired connection cable is used, remove the cores with unused signal inputs and outputs.

Unused cores, in particular core loops, lead to interference coupling that can influence the connected controller.

4.2 Ground connection



To ensure the protection of the device against electrical interference and the safe function of the device, the housing must be connected to the ground of the vehicle.

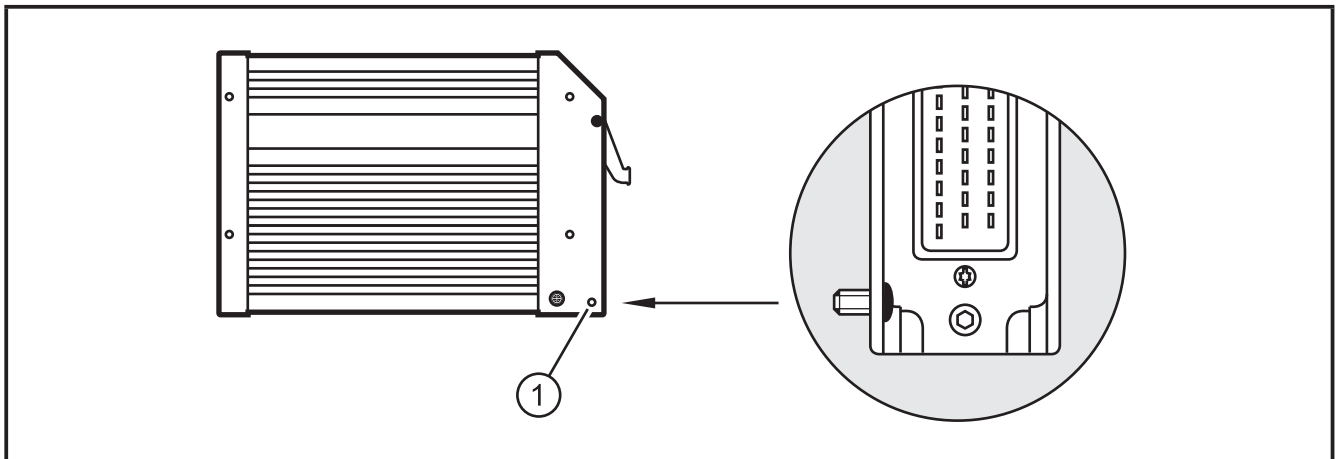

1: Drill hole for ground connection

- ▶ Establish a connection between the device and the ground of the vehicle using M5 screws.
Screws to be used (→ 3.1 Fixing)

4.3 Fuses

- ▶ The individual electric circuits must be protected in order to protect the whole system.

Designation	Potential	Pin no.	Fuse
Supply voltage sensors/module	VBB _S	23	max. 2 A T
Supply voltage outputs	VBB _O	05	max. 15 A
Supply voltage via relay	VBB _R	34	max. 15 A

4.4 Laying the supply and signal cables

- ▶ Basically all supply and signal cables must be laid separately.
- ▶ Screen signal cables in EMC critical applications.

- ▶ Connect supply and ground cables to the controller and the sensors/actuators via the respective common star point.

⚠ WARNING

The linking of connections in the plug is not permitted and can affect the safety of operators and machinery.

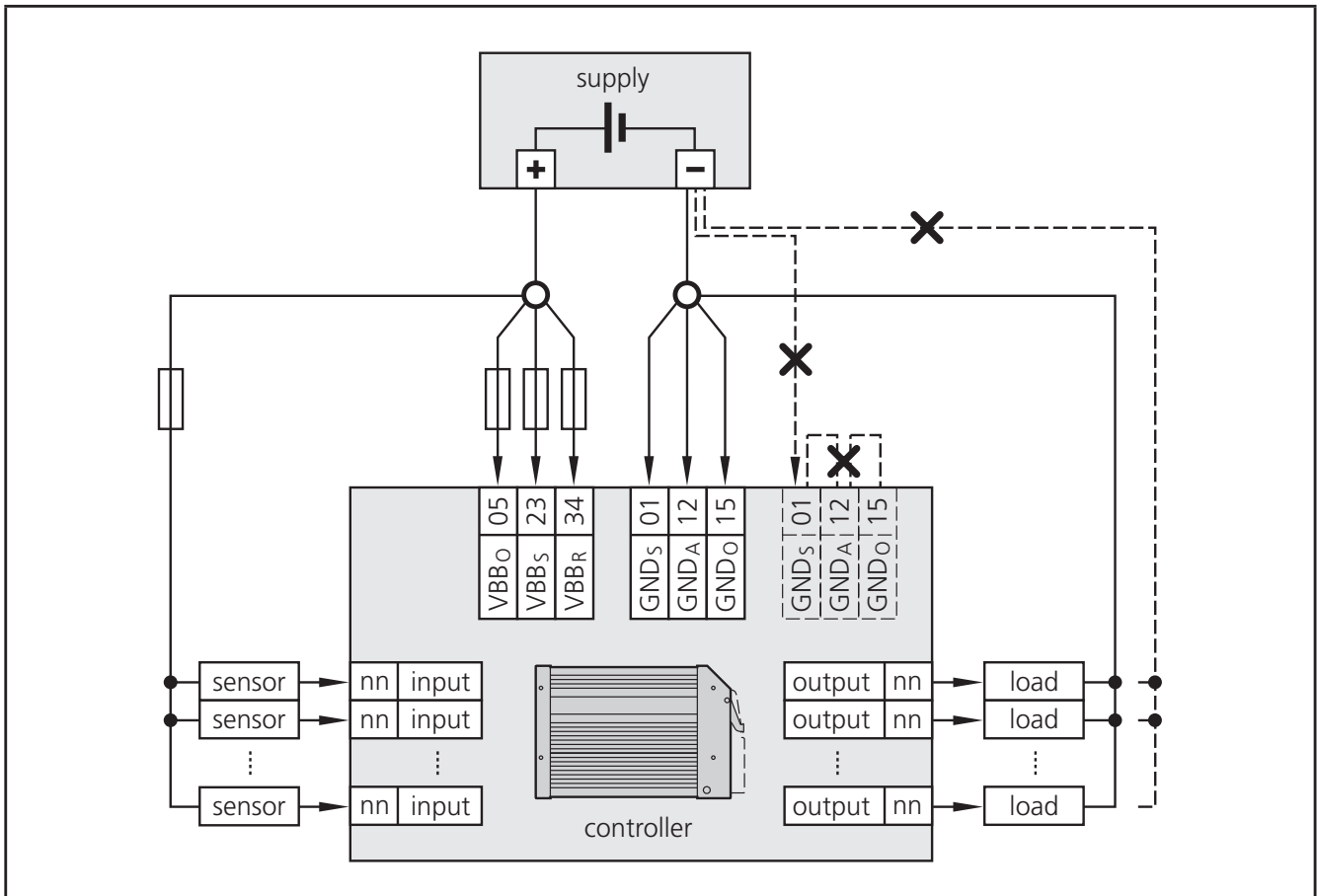

X = not permissible

4.5 Interaction between inputs/outputs in an output group

In safety-related applications the following must be observed as regards the use of the terminals as input and output.

- ▶ Do not combine inputs and outputs within an output group.

The background is a possible internal cross-connection of the outputs from externally supplied inputs. This may occur unexpectedly if the supply to the outputs is switched-off externally.



An output group is identified by a common VBB potential (here VBB_O and VBB_R).

If, however, inputs and outputs are combined for optimisation of the terminals, an internal cross-connection of the outputs is possible and thus, in the worst case, the loss of the safety function of the outputs of this group.

5 Technical data

CR7506

Mobile controller
SafetyController

EN ISO 13849-1:2008 Category 3 PL d
IEC 62061:2005 SIL CL 2

CANopen safety

2 CAN interfaces

CoDeSys 2.3

10...32 V DC

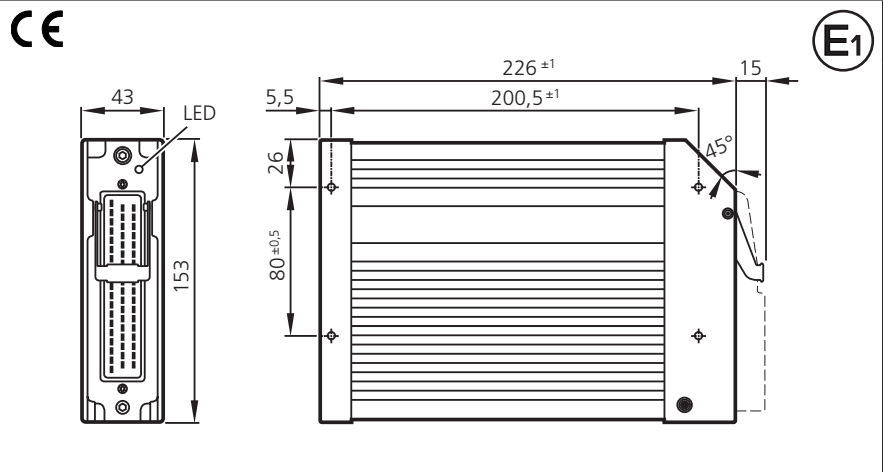

Technical data

Housing

Dimensions (H x W x D)

Installation

Connection

Weight

Housing/storage temperature

Protection rating

Input/output channels (total)

Inputs

Outputs

Operating voltage U_b

Overvoltage
Undervoltage detection
Switching-off in case of
undervoltage

Current consumption

CAN interface 1

Baud rate
Communication profile
Node ID (CANopen)

CAN interface 2

Baud rate
Communication profile

Serial interface

Baud rate
Topology
Protocol

Processor

Memory

Controller as black-box system to implement a central or decentralised system design

closed, screened metal housing with flange fastening

153 x 226 x 43 mm

screw connection by means of 4 M5 x L screws to DIN 7500 or DIN 7984
mounting position horizontal or vertical to the mounting wall

1 55-pin connector, latched, protected against reverse polarity
type AMP or Framatome
AMP junior timer contacts, crimp connection 0.5/2.5 mm²

1.2 kg

- 40...75 °C (depending on the load) / - 40...85 °C

IP 67 (for inserted connector with individually sealed cores, e.g. EC2084)

max. 24
(depending on the wiring and configuration of the controller)

max. 20 (corr. to 4 outputs)

max. 8 (corr. to 16 inputs)

10...32 V DC

36 V for $t \leq 10$ s
at $U_b \leq 10$ V
at $U_b \leq 8$ V

≤ 160 mA (without external load at 24 V DC)

CAN interface 2.0 A/B, ISO 11898

50 Kbits/s...1 Mbit/s (default 125 Kbits/s)
CANopen, CiA DS 301 version 4, CiA DS 401 version 1.4
hex 7F (= dec 127)

CAN interface 2.0 A/B, ISO 11898

50 Kbits/s...1 Mbit/s (default 125 Kbits/s)
SAE J 1939 or free protocol

RS-232 C

9.6...57.6 Kbits/s (default 57.6 Kbits/s)
point-to-point (max. 2 participants); master-slave connection
predefined ifm protocol (INTELHEX)

CMOS microcontroller 16 bits C167CS
clock frequency 40 MHz

see system manual "SafetyController"
(www.ifm.com → Data sheet direct → CR7506 → Additional data)

CR7506	Technical data
Device monitoring	undervoltage monitoring watchdog function (extended safety monitoring according to IEC 62061 and ISO 13849) checksum test for program and system excess temperature monitoring
Process monitoring concept	second switch-off mode for 12 outputs via a monitoring relay (according to IEC 62061 and ISO 13849)
	Safety-related characteristics
According to IEC 62061:2005	
Safety Integrity Level Claim Limit	SIL CL 2
Probability of Dangerous Failure per Hour	3.5×10^{-8} 1/h
According to ISO 13849-1:2008	
Performance Level	PL d
	Test standards and regulations
Climatic test	damp heat to EN 60068-2-30, test Db ($\leq 95\%$ rel. air humidity) salt mist test to EN 60068-2-52, test Kb, severity level 3 degree of protection test to EN 60529
Mechanical stability	vibration, sinusoidal to EN 60068-2-6 Test Fc vibration, broadband random to EN 60068-2-64, test Fh bump to EN 60068-2-29, test Eb
Immunity to conducted interference	to ISO 7637-2: 2004 pulses 1, 2b, severity level 4, function state C pulses 2a, 3a, 3b, 4, severity level 4, function state A pulses 5a, severity level 3, function state A
Immunity to interfering fields	to UN/ECE-R10 at 100 V/m (E1 type approval) EN 61000-6-2: 2005 (CE)
Interference emission	to UN/ECE-R10 (E1 type approval) EN 61000-6-4: 2007 (CE)
Certification	according to test basis to IEC 62061 and ISO 13849-1
Tests for approval for railway applications	BN 411 002 (DIN EN 50155 point 10.2)

UK

CR7506

Status indication

Operating states

Technical data

three-colour LED (R/G/B)

LED colour	Status	Description
–	off	no operating voltage
yellow	1 x on	initialisation or reset checks
orange	on	error in the start-up phase
green	5 Hz	no operating system loaded
	2 Hz	run
	on	stop
red	2 Hz	run with error
	on	fatal error or stop with error

CR7506
Input channels
Possible configurations
Output channels
Possible configurations
Legend

Technical data																													
<table border="1"> <thead> <tr> <th>Number</th> <th>Signal</th> <th>Version</th> <th></th> <th></th> </tr> </thead> <tbody> <tr> <td>8 or</td> <td>digital analogue</td> <td>for positive sensor signals 0...10/32 V, 0/4...20 mA or ratiometric</td> <td>B_L A</td> <td>▲ ▲</td> </tr> <tr> <td>4</td> <td>digital</td> <td>for positive sensor signals</td> <td>B_L</td> <td>–</td> </tr> <tr> <td>4 or</td> <td>digital frequency</td> <td>for positive sensor signals max. 30 kHz</td> <td>B_L I_L</td> <td>▲ –</td> </tr> <tr> <td>4 or</td> <td>digital frequency</td> <td>for positive sensor signals max. 1 kHz</td> <td>B_L I_L</td> <td>▲ –</td> </tr> </tbody> </table>					Number	Signal	Version			8 or	digital analogue	for positive sensor signals 0...10/32 V, 0/4...20 mA or ratiometric	B _L A	▲ ▲	4	digital	for positive sensor signals	B _L	–	4 or	digital frequency	for positive sensor signals max. 30 kHz	B _L I _L	▲ –	4 or	digital frequency	for positive sensor signals max. 1 kHz	B _L I _L	▲ –
Number	Signal	Version																											
8 or	digital analogue	for positive sensor signals 0...10/32 V, 0/4...20 mA or ratiometric	B _L A	▲ ▲																									
4	digital	for positive sensor signals	B _L	–																									
4 or	digital frequency	for positive sensor signals max. 30 kHz	B _L I _L	▲ –																									
4 or	digital frequency	for positive sensor signals max. 1 kHz	B _L I _L	▲ –																									
<table border="1"> <thead> <tr> <th>Number</th> <th>Signal</th> <th>Version</th> <th></th> <th></th> </tr> </thead> <tbody> <tr> <td>4 or or</td> <td>digital PWM current- controlled</td> <td>positive-switching (high side), with diagnostic capability PWM frequency 20...250 Hz 0.1...4 A</td> <td>B_H PWM PWM_I</td> <td>– – –</td> </tr> <tr> <td>4 or or</td> <td>digital PWM current- controlled</td> <td>positive-switching (high side), with diagnostic capability PWM frequency 20...250 Hz 0.1...4 A</td> <td>B_H PWM PWM_I</td> <td>▲ – –</td> </tr> </tbody> </table>					Number	Signal	Version			4 or or	digital PWM current- controlled	positive-switching (high side), with diagnostic capability PWM frequency 20...250 Hz 0.1...4 A	B _H PWM PWM _I	– – –	4 or or	digital PWM current- controlled	positive-switching (high side), with diagnostic capability PWM frequency 20...250 Hz 0.1...4 A	B _H PWM PWM _I	▲ – –										
Number	Signal	Version																											
4 or or	digital PWM current- controlled	positive-switching (high side), with diagnostic capability PWM frequency 20...250 Hz 0.1...4 A	B _H PWM PWM _I	– – –																									
4 or or	digital PWM current- controlled	positive-switching (high side), with diagnostic capability PWM frequency 20...250 Hz 0.1...4 A	B _H PWM PWM _I	▲ – –																									
<p>▲ safety-related – not safety-related A analogue B_H binary high side B_L binary low side FRQ/CYL frequency inputs I_H pulse high side I_L pulse low side PWM pulse width modulation PWM_I current-controlled output %IW... IEC address for analogue input IX IEC address for binary input %QX... IEC address for binary output H H bridge function VBB_O supply outputs VBB_S supply sensors/module VBB_R supply via relay</p>																													
<p>Observe the notes on the configuration of the inputs/outputs! (→ system manual "SafetyController")</p> <p>Ensure that the channels are not used as inputs/outputs at the same time!</p>																													



CR7506	Characteristics of the inputs
Digital/analogue inputs ▲ %IX0.00...07 ▲ %IW03...10 can be configured as:	Digital inputs for positive sensor signals (B_L) Switch-on level 0.7 U_B Switch-off level 0.4 U_B Input resistance 30 k Ω Input frequency 50 Hz Voltage/current inputs (A) Input voltage 0...10/32 V Input current 0/4...20 mA Resolution 12 bits Accuracy $\pm 1.0\%$ FS Input resistance 50/30 k Ω (voltage) Input resistance 400 Ω (current) Input frequency 50 Hz
Digital inputs – %IX0.08...11 can be configured as:	Digital inputs for positive sensor signals (B_L) Switch-on level 0.43...0.73 U_B Switch-off level 0.29 U_B Input resistance 3.21 k Ω Input frequency 50 Hz
Digital inputs ▲ %IX0.12...15 can be configured as:	Digital inputs for positive sensor signals (B_L) Switch-on level 0.7 U_B Switch-off level 0.4 U_B Input resistance 2.86 k Ω Input frequency 50 Hz Frequency inputs for positive sensor signals (I_L), evaluation with integrated comparator Switch-on level 0.43...0.73 U_B Switch-off level 0.29 U_B Input resistance 2.86 k Ω Input frequency ≤ 30 kHz
Digital inputs ▲ %IX1.04...07 can be configured as:	Digital inputs for positive sensor signals (B_L) Switch-on level 0.7 U_B Switch-off level 0.4 U_B Input resistance 3.21 k Ω Input frequency 50 Hz Frequency inputs for positive sensor signals (I_L), evaluation with integrated comparator Switch-on level 0.43...0.73 U_B Switch-off level 0.29 U_B Input resistance 3.21 k Ω Input frequency ≤ 1 kHz
Test input Observe the special notes in the system manual "SafetyController".	The test input must be active if for example software is to be loaded to the controller (pin 24 to V_{BB_s} , 10...32 V DC). Safety-related outputs (MODE byte OUT_Safety) cannot be used with an active test input. To have them available again the test input must be deactivated and a reset must be carried out. (Reset = power off/on of the controller) While the machine is in operation the test input must be connected to GND. Input resistance 3.21 k Ω
▲ = safety-related	Observe the notes on the configuration of the inputs/outputs! (→ system manual "SafetyController") Frequency inputs are only safety-related if combined!

CR7506	Characteristics of the outputs
Outputs – %QX0.00...03 ▲ %QX0.04...07 can be configured as:	Semiconductor outputs, with diagnostic capability (B _H) positive switching (high side), short-circuit proof and overload protected Switching voltage 10...32 V DC Switching current ≤ 4 A Output frequency ≤ 100 Hz (depending on the load) PWM outputs, diagnosis via current feedback (PWM) PWM frequency ≤ 250 Hz Pulse/pause ratio 1...99 % Resolution depending on the PWM frequency Load current ≤ 4 A Current-controlled outputs, diagnosis via current feedback (PWM) Load current 0.1...4 A Load resistance ≥ 3 Ω (U _B = 12 V DC) ≥ 6 Ω (U _B = 24 V DC) Setting resolution 1 mA Control resolution 5 mA Accuracy ± 2% FS
Output error	Semiconductor output (B _H), positive switching (high side) Switching voltage 10...32 V DC Switching current ≤ 100 mA Overload current 0.5 A Switching function OFF (0 V) in case of an error
Internal relay outputs for the additional switch-off of the outputs	Normally open contacts in series to 2 groups of 4 semiconductor outputs. Forced controlling by means of co-processor and additional controlling by means of user program. Switch relays without load! Total current max. 12 A per group Switching current 0.1...15 A Overload current 20 A Number of operating cycles (without load) ≥ 10 ⁶ Switching time constant ≤ 3 ms
Definition of short-circuit and overload protection	Definition of short circuit: short circuit to VBB and GND for 5 min Definition of overload: 100 % overload at the output for 5 min
Legend	▲ safety-related – not safety-related A analogue B _H binary high side B _L binary low side FRQ/CYL frequency inputs I _H pulse high side I _L pulse low side PWM pulse width modulation PWM _i current-controlled output %IW... IEC address for analogue input %IX... IEC address for binary input %QX... IEC address for binary output H H bridge function VBB _o supply outputs VBB _s supply sensors/module VBB _R supply via relay
	*) only high side outputs safety-related Observe the notes on the configuration of the inputs/outputs! (→ system manual "SafetyController")

CR7506 wiring										
23	VBB _s (10...32 V DC)	supply of sensors and module								
05	VBB _o (10...32 V DC)	supply outputs								switched via relay (1)
34	VBB _r (10...32 V DC)	supply via relay								switched via relay (2)
01	GND _s	ground sensors and module								
15	GND _o	ground outputs								
12	GND _a	ground analogue inputs								
14	CAN1_H	CAN interface 1 (high)								
32	CAN1_L	CAN interface 1 (low)								
26	CAN2_H	CAN interface 2 (high)								SAE J 1939
25	CAN2_L	CAN interface 2 (low)								SAE J 1939
33	GND	ground RS-232 / CAN								
06	RxD	RS-232 interface (programming)								pin 03 (D-Sub, 9-pole)
07	TxD	RS-232 interface (programming)								pin 02 (D-Sub, 9-pole)
13	Error	error output B _h								
24	TEST	TEST input								
Inputs					Outputs					with diagnostic capability
08	%IX0.00 / %IW03	B _L	A	▲	-	-	-	-	-	- / -
27	%IX0.01 / %IW04	B _L	A	▲	-	-	-	-	-	- / -
09	%IX0.02 / %IW05	B _L	A	▲	-	-	-	-	-	- / -
28	%IX0.03 / %IW06	B _L	A	▲	-	-	-	-	-	- / -
10	%IX0.04 / %IW07	B _L	A	▲	-	-	-	-	-	- / -
29	%IX0.05 / %IW08	B _L	A	▲	-	-	-	-	-	- / -
11	%IX0.06 / %IW09	B _L	A	▲	-	-	-	-	-	- / -
30	%IX0.07 / %IW10	B _L	A	▲	-	-	-	-	-	- / -
44	%IX0.08	B _L	-	-	%QX0.00	B _H	PWM	PWM _I	-	- / ● VBB _o (1)
45	%IX0.09	B _L	-	-	%QX0.01	B _H	PWM	PWM _I	-	- / ● VBB _o (1)
46	%IX0.10	B _L	-	-	%QX0.02	B _H	PWM	PWM _I	-	- / ● VBB _o (1)
47	%IX0.11	B _L	-	-	%QX0.03	B _H	PWM	PWM _I	-	- / ● VBB _o (1)
20	%IX0.12	B _L	I _L (FRQ0)*	▲	-	-	-	-	-	- / -
02	%IX0.13	B _L	I _L (FRQ1)*	▲	-	-	-	-	-	- / -
21	%IX0.14	B _L	I _L (FRQ2)*	▲	-	-	-	-	-	- / -
38	%IX0.15	B _L	I _L (FRQ3)*	▲	-	-	-	-	-	- / -
36	-	-	-	-	%QX0.04	B _H	PWM**	PWM _I **	▲	- / ● VBB _r (2)
54	-	-	-	-	%QX0.05	B _H	PWM**	PWM _I **	▲	- / ● VBB _r (2)
17	-	-	-	-	%QX0.06	B _H	PWM**	PWM _I **	▲	- / ● VBB _r (2)
53	-	-	-	-	%QX0.07	B _H	PWM**	PWM _I **	▲	- / ● VBB _r (2)
19	%IX1.04	B _L	I _L (CYL0)*	▲	-	-	-	-	-	- / -
55	%IX1.05	B _L	I _L (CYL1)*	▲	-	-	-	-	-	- / -
18	%IX1.06	B _L	I _L (CYL2)*	▲	-	-	-	-	-	- / -
37	%IX1.07	B _L	I _L (CYL3)*	▲	-	-	-	-	-	- / -

*) Frequency inputs are only safety-related if combined
▲ = safety-related

**) only high side outputs safety-related

● = with diagnostic capability

Observe the notes on the configuration of the inputs/outputs!
(→ system manual "SafetyController")

6 Maintenance, repair and disposal

The device is maintenance-free.

- ▶ Do not open the housing as the device does not contain any components which must be maintained by the user. The device must only be repaired by the manufacturer.
- ▶ Dispose of the device in accordance with the national environmental regulations.

7 Approvals/standards

Test standards and regulations (→ 5 Technical data)

The EC declaration of conformity and approvals can be found at:
www.ifm.com

UK