

80263024 / 00 07 / 2019

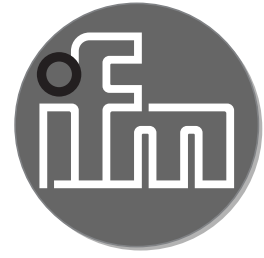

Operating instructions  
5-segment signal lamp

**DV15x0**

**DV25x0**

**UK**

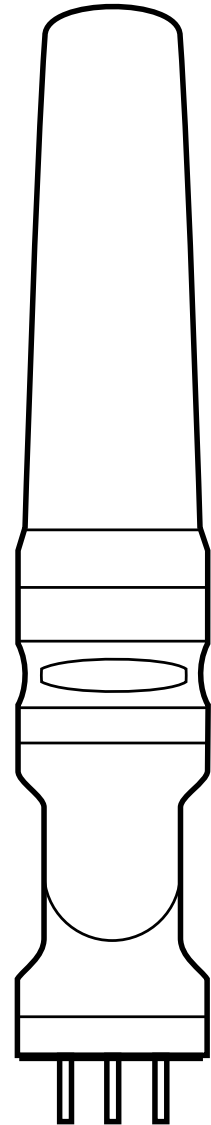

# Contents

1	Preliminary note.....	4
1.1	Key to the symbols .....	4
2	Safety instructions .....	5
3	Functions and features .....	5
3.1	IO-Link .....	6
3.1.1	General information .....	6
3.1.2	Device-specific information.....	6
4	Installation.....	6
5	Electrical connection.....	7
5.1	IO-Link connection.....	7
6	Pin configuration.....	8
6.1	IO-Link device (DV25x0) .....	8
6.2	Standard device (DV15x0) .....	8
7	Operating and display elements .....	9
8	Operation.....	10
8.1	Operation of the IO-Link version.....	10
8.1.1	General.....	10
8.1.2	On/off mode.....	10
8.1.3	RGB mode.....	11
8.1.4	Analogue mode.....	12
8.2	Operation of the standard version .....	14
8.3	Demo mode .....	14
9	Parameter setting .....	14
9.1	IO-Link version.....	14
9.2	Standard version .....	15
9.2.1	Parameter structure.....	16
10	Scale drawing .....	17
10.1	DVx500.....	17
10.2	DVx510.....	18
10.3	DVx520.....	19
10.4	DVx530.....	20

- 11 Technical data .....21
  - 11.1 IO-Link device .....21
- 12 Maintenance, repair and disposal.....22
  - 12.1 Cleaning the housing surface .....22
- 13 Approvals/standards .....22

# 1 Preliminary note

Technical data, approvals, accessories and further information at [www.ifm.com](http://www.ifm.com).

## 1.1 Key to the symbols

▶ Instructions

> Reaction, result

[...] Designation of keys, buttons or indications

→ Cross-reference



Important note

Non-compliance may result in malfunction or interference.



Information

Supplementary note.

### **WARNING**

Warning of serious personal injury.

Death or serious irreversible injuries may result.

### **CAUTION**

Warning of personal injury.

Slight reversible injuries may result.

### **ATTENTION**

Warning of damage to property

## 2 Safety instructions

- Read this document before setting up the product and keep it during the entire service life.
- The product must be suitable for the corresponding applications and environmental conditions without any restrictions.
- Only use the product for its intended purpose (→ 3 Functions and features).
- If the operating instructions or the technical data are not adhered to, personal injury and/or damage to property may occur.
- The manufacturer assumes no liability or warranty for any consequences caused by tampering with the product or incorrect use by the operator.
- Installation, electrical connection, set-up, operation and maintenance of the product must be carried out by qualified personnel authorised by the machine operator.
- Protect units and cables against damage.

UK

## 3 Functions and features

The unit is used to visually display machine conditions. The versions DVx510 and DVx530 additionally have a buzzer for acoustic signalling.

The 5 LED segments and the audible warning device can be switched on and off individually.



- ▶ The device is intended for indoor use only.  
Observe the operating conditions (→ 11 Technical data).



- ▶ The unit must not be used for safety-related applications such as access control.

The standard units are DV15xx. The DV25xx units are IO-Link devices. The IO-Link version can be triggered and configured via the standard IO-Link interface. With the standard version the individual LED segments can be switched individually via digital inputs. Parameters are set via a parameter setting button or via an additional IO-Link interface.

If the equipment is used in a manner not specified by the manufacturer, the protection provided by the equipment may be impaired.

## 3.1 IO-Link

### 3.1.1 General information

This unit has an IO-Link communication interface which enables direct access to process and diagnostic data. In addition it is possible to set the parameters of the unit while it is in operation. Operation of the unit via an IO-Link interface requires an IO-Link capable module (IO-Link master).

### 3.1.2 Device-specific information

With a PC, suitable IO-Link software and an IO-Link adapter cable communication is possible when the system is not in operation. The IODDs necessary for the configuration of the unit, detailed information about process data structure, diagnostic information, parameter addresses and the necessary information about the required IO-Link hardware and software can be found at [www.ifm.com](http://www.ifm.com).

## 4 Installation



▶ Disconnect power before installation.



▶ For installation choose a flat mounting surface.

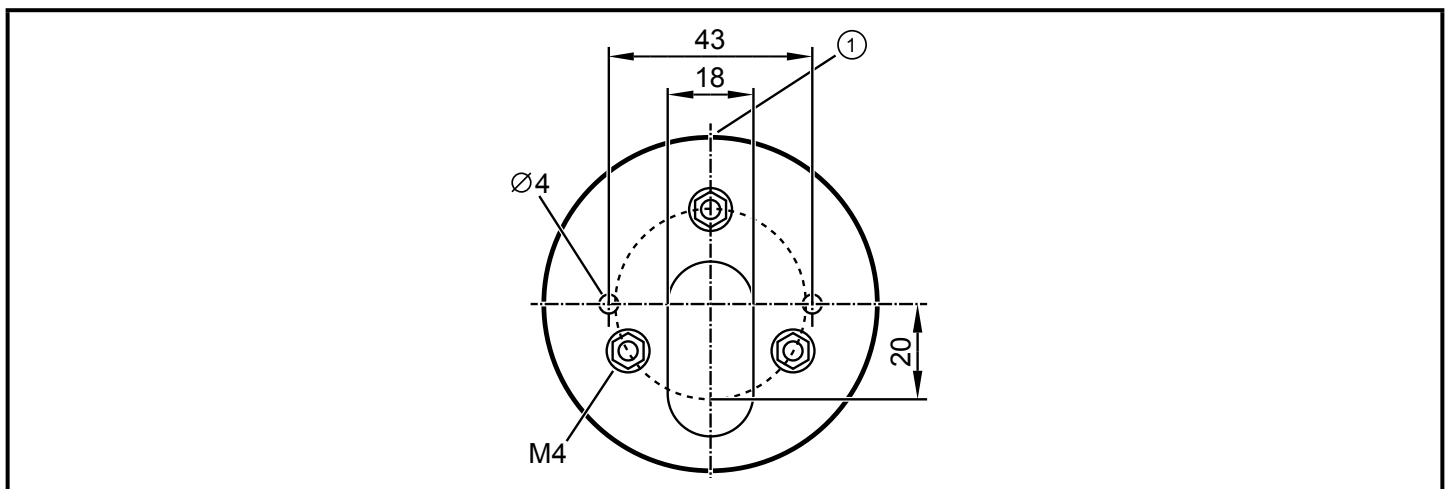

Fixture (view from bottom)

1: Front side

- ▶ Attach the fixture for the unit to the mounting surface using the supplied M4 nuts. Tightening torque 1.8 Nm.
- ▶ Only with the models DVx500 and DVx510:  
For mounting on a horizontal surface attach the base to the fixture (overlapping marks on base and fixture) and turn clockwise by approx. 10 ° to fix it. For mounting on a vertical surface loosen the screw in the base, turn the upper part

of the base by 180 ° and tighten the screw again. Attach the base to the fixture (overlapping marks on base and fixture) and turn clockwise by approx. 10 ° to fix it.

- ▶ Insert the cable through the fixture and, if necessary, the base and connect the socket with the M12 connector in the signal lamp. Tightening torque max. 1 Nm.
- ▶ Attach the signal lamp to the fixture or the base (overlapping marks) and turn clockwise by approx. 10 ° to fix it.



Observe the maximum tightening torque of the connection cable.

UK



Integrated seals at the bottom of the fixture and in the base as well as O-rings at the fixture and base prevent ingress of moisture.

More information about available accessories at [www.ifm.com](http://www.ifm.com)

## 5 Electrical connection



The unit must be connected by a qualified electrician.

The national and international regulations for the installation of electrical equipment must be adhered to.

Voltage supply according to SELV, PELV

- ▶ Disconnect power.
- ▶ Connect the unit.

### 5.1 IO-Link connection

The IO-Link port must be connected according to the IO-Link specification.

# 6 Pin configuration

## 6.1 IO-Link device (DV25x0)

### M12 connector IO-Link, 4 poles

(4 x 0.34 mm<sup>2</sup> / AWG 22)

- 1: UB+
- 2: not used
- 3: UB-
- 4: IO-Link

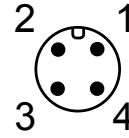

## 6.2 Standard device (DV15x0)

### M12 connector, 8 poles

(8 x 0.25 mm<sup>2</sup> / AWG 24)

- 1: LED segment 5
- 2: buzzer (DV1510 and DV1530)
- 3: LED segment 3
- 4: LED segment 2
- 5: voltage supply
- 6: LED segment 1
- 7: LED segment 4
- 8: IO-Link

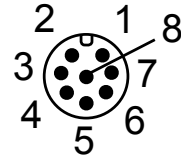

The input polarity is selectable.

- ▶ Connect pin 5 to +24 V DC to trigger the inputs with an NPN transistor.
- ▶ Connect pin 5 to GND to trigger the inputs with a PMP transistor.



When triggered via IO-Link (pin 8) without connection cable E12572:

- ▶ Connect pin 5 to +24 V DC.
- ▶ Connect pin 3 to GND.

## 7 Operating and display elements

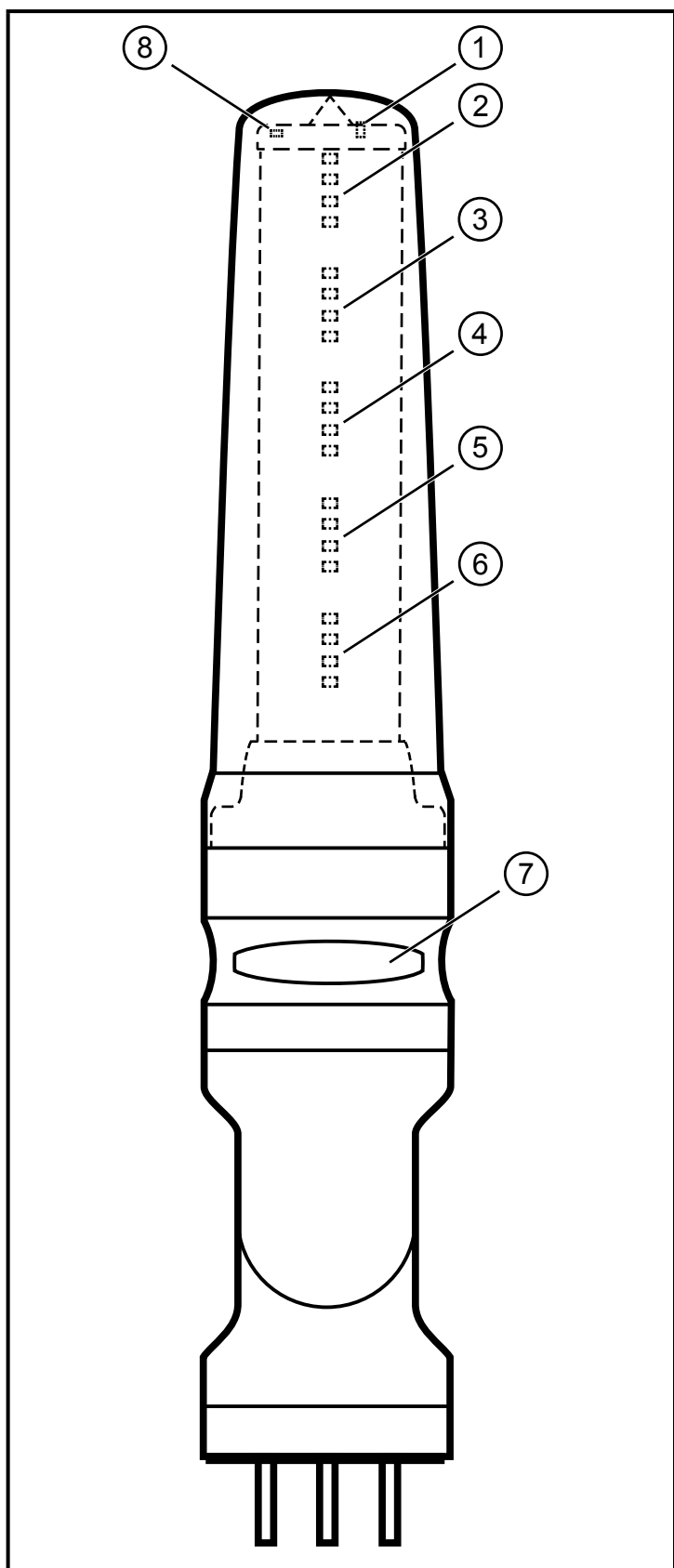

- 1: Parameter setting button (only DV15x0)
- 2: LED segment 1 with 4 RGB LEDs
- 3: LED segment 2 with 4 RGB LEDs
- 4: LED segment 3 with 4 RGB LEDs
- 5: LED segment 4 with 4 RGB LEDs
- 6: LED segment 5 with 4 RGB LEDs
- 7: Buzzer (only DVx510 and DVx530)
- 8: Feedback LED (only DV15x0)

# 8 Operation

## 8.1 Operation of the IO-Link version

### 8.1.1 General

The unit is connected to an IO-Link master (A port) with a 4-pole connection cable. The controller switches the individual LED segments on and off in the configured colours according to the set parameters.

Via the parameter "Operating mode" the following modes can be set:

- On/off mode
- RGB mode
- Analogue mode

### 8.1.2 On/off mode

While in operation, the controller switches the 5 LED segments and the buzzer (only with DVx510 and DVx530) on and off (PDout, cyclical data communication). Signalling corresponds to the pre-defined parameters for the individual LED segments and the buzzer.

Via the acyclic parameter setting the following properties can be set for every LED segment:

- Colour (red, green, orange, blue, violet, turquoise, white, yellow, off)
- Frequency (permanently on, low flash rate slow/medium/fast, high flash rate slow/medium/fast)
- Brightness (100 %, 75 %, 50 %, 25 %)

For the models with an acoustic signal device the audibility of the buzzer can be set.

7	6	5	4	3	2	1	0	PDout
			Seg. 5	Seg. 4	Seg. 3	Seg. 2	Seg. 1	Byte 0
								Byte 1
								Byte 2
								Byte 3
								Byte 4
	Buzzer sound (buzzer style 1...8)						Buzzer	Byte 5

### 8.1.3 RGB mode

While in operation the controller switches the 5 LED segments and the buzzer on and off (only with DVx510 and DVx530), defining the respective properties (PDout, cyclical data communication).

In this operating mode, 8 different acoustic signals are available for the buzzer.

7	6	5	4	3	2	1	0	PDout
	Segment 1 LED properties			Seg. 1 yellow	Seg. 1 red	Seg. 1 green	Seg. 1 blue	Byte 0
	Segment 2 LED properties			Seg. 2 yellow	Seg. 2 red	Seg. 2 green	Seg. 2 blue	Byte 1
	Segment 3 LED properties			Seg. 3 yellow	Seg. 3 red	Seg. 3 green	Seg. 3 blue	Byte 2
	Segment 4 LED properties			Seg. 4 yellow	Seg. 4 red	Seg. 4 green	Seg. 4 blue	Byte 3
	Segment 5 LED properties			Seg. 5 yellow	Seg. 5 red	Seg. 5 green	Seg. 5 blue	Byte 4
	Buzzer sound (buzzer style 1..8)						Buzzer	Byte 5

The properties of the LED segments are defined as follows:

3	2	1	0	Colour
0	0	0	0	off
0	1	0	0	red
0	0	1	0	green
0	1	1	0	orange
0	0	0	1	blue
0	1	0	1	violet
0	0	1	1	turquoise
0	1	1	1	white
1	0	0	0	yellow

6	5	4	Frequency
0	0	0	permanently on
0	0	1	low flash rate slow
0	1	0	low flash rate medium
0	1	1	low flash rate fast
1	0	0	high flash rate slow
1	0	1	high flash rate medium
1	1	0	high flash rate fast

### 8.1.4 Analogue mode

While in operation the controller transmits an analogue value between 0 and 100 % in byte 0 via PDout %. Byte 1 determines the representation of the visual signalling. 9 different representations are possible.

Byte 5 defines the acoustic signal (only with DVx510 and DVx530). 8 different acoustic signals are available.

7	6	5	4	3	2	1	0	PDout
Analogue value 0...100 %								Byte 0
				Representation LED (style 1...9)				Byte 1
								Byte 2
								Byte 3
								Byte 4
Buzzer sound (buzzer style 1...8)				Buzzer				Byte 5

The signal lamp generates the following visual indications of the analogue value depending on the data in byte 1.

	Analogue value: 0 %	1-10 %	11-20 %	21-30 %	31-40 %	41-50 %	51-60 %	61-70 %	71-80 %	81-90 %	91-99 %	100 %	
Style 1										white	white	white	Segment 1
										white	white	white	Segment 2
						white	white	white	white	white	white	white	Segment 3
				white	white	white	white	white	white	white	white	white	Segment 4
	white	white	white	white	white	white	white	white	white	white	white	white	Segment 5
Style 2													Segment 1
													Segment 2
				white	white	white	white	white	white	white	white	white	Segment 3
				white	white	white	white	white	white	white	white	white	Segment 4
	white	white	white	white	white	white	white	white	white	white	white	white	Segment 5
Style 3													Segment 1
													Segment 2
						white	white	white	white	white	white	white	Segment 3
				white	white	white	white	white	white	white	white	white	Segment 4
	white	white	white	white	white	white	white	white	white	white	white	white	Segment 5
Style 4													Segment 1
													Segment 2
				white	white	white	white	white	white	white	white	white	Segment 3
				white	white	white	white	white	white	white	white	white	Segment 4
	white	white	white	white	white	white	white	white	white	white	white	white	Segment 5
Style 5	green	green	green	green	green	green	green	green	green	blue	blue	blue	Segment 1
	green	green	green	green	green	green	green	blue	blue	green	green	green	Segment 2
	green	green	green	green	green	blue	blue	green	green	green	green	green	Segment 3
	green	green	green	blue	blue	green	green	green	green	green	green	green	Segment 4
	blue	blue	blue	green	green	green	green	green	green	green	green	green	Segment 5
Style 6	red	red	red	red	red	red	red	red	red	blue	blue	blue	Segment 1
	red	red	red	red	red	red	red	blue	blue	red	red	red	Segment 2
	red	red	red	red	red	blue	blue	red	red	red	red	red	Segment 3
	red	red	red	blue	blue	red	red	red	red	red	red	red	Segment 4
	blue	blue	blue	red	red	red	red	red	red	red	red	red	Segment 5
Style 7	orange	orange	orange	orange	orange	orange	orange	orange	orange	blue	blue	blue	Segment 1
	orange	orange	orange	orange	orange	orange	orange	blue	blue	orange	orange	orange	Segment 2
	orange	orange	orange	orange	orange	blue	blue	orange	orange	orange	orange	orange	Segment 3
	orange	orange	orange	blue	blue	orange	orange	orange	orange	orange	orange	orange	Segment 4
	blue	blue	blue	orange	orange	orange	orange	orange	orange	orange	orange	orange	Segment 5
Style 8													Segment 1
													Segment 2
						white	white	white	white	white	white	white	Segment 3
				white	white	white	white	white	white	white	white	white	Segment 4
	white	white	white	white	white	white	white	white	white	white	white	white	Segment 5
Style 9													Segment 1
													Segment 2
				white	white	white	white	white	white	white	white	white	Segment 3
				white	white	white	white	white	white	white	white	white	Segment 4
	white	white	white	white	white	white	white	white	white	white	white	white	Segment 5
Style 10	yellow	yellow	yellow	yellow	yellow	yellow	yellow	yellow	yellow	blue	blue	blue	Segment 1
	yellow	yellow	yellow	yellow	yellow	yellow	yellow	blue	blue	yellow	yellow	yellow	Segment 2
	yellow	yellow	yellow	yellow	yellow	blue	blue	yellow	yellow	yellow	yellow	yellow	Segment 3
	yellow	yellow	yellow	blue	blue	yellow	yellow	yellow	yellow	yellow	yellow	yellow	Segment 4
	blue	blue	blue	yellow	yellow	yellow	yellow	yellow	yellow	yellow	yellow	yellow	Segment 5

UK

## 8.2 Operation of the standard version

The unit is connected to the digital outputs of the controller via an 8-pole cable (see accessories at [www.ifm.com](http://www.ifm.com)). The 6 HTTL inputs of the signal lamp are triggered with 24 V DC. According to the set parameters, the 5 LED segments are on and the buzzer sounds (only with DVx510 and DVx530).

The signal inputs can be triggered either in PNP or in NPN technology (→ 6.2 Standard device (DV15x0)).

With the parameter setting button the following properties can be set for every LED segment:

- Colour (red, green, orange, blue, violet, turquoise, white, yellow, off)
- Frequency (permanently on, low flash rate slow/medium/fast, high flash rate slow/medium/fast)
- Brightness (100 %, 75 %, 50 %, 25 %)

Parameter setting via the IO-Link interface (pin 8 of the M12 connector) is also possible.

After parameter setting, the unit goes to the Run mode.

## 8.3 Demo mode

In demo mode, the unit demonstrates the different

- colours
  - visual indications of analogue values (styles)
  - buzzer sounds (buzzer styles, provided the unit features a buzzer)
- Set the parameter [Demo mode] in the IO-Link parameter setting tool (e.g. LR DEVICE). For SIO and IO-Link mode, the demo is available in 3 different speeds, respectively.

# 9 Parameter setting

## 9.1 IO-Link version

The unit can be configured using an IO-Link parameter setting tool (e.g. LR DEVICE) (→ 3.1 IO-Link).

More information is given in the IODD at [www.ifm.com](http://www.ifm.com).

## 9.2 Standard version

- ▶ Turn the transparent protective cover anticlockwise by approx. 10 ° and remove it.
- ▶ Briefly press the parameter setting button at the head of the unit (< 5 s).
  - > The feedback LED is green on.  
The unit is in the parameter setting mode.
- ▶ Briefly press the parameter setting button (< 5 s) to go to the next parameter.
- ▶ Press the parameter setting button for a longer time (> 5 s) to set the selected parameter.
  - > The feedback LED flashes green.  
The unit indicates the current settings of the LED segment to be configured.
- ▶ Briefly press the parameter setting button (< 5 s) to change the value for the selected parameter. Repeat this step until the requested setting is selected.
  - > The unit indicates the current settings of the LED segment to be configured.
- ▶ Press the parameter setting button for a longer time (> 5 s) to save the selected value for this parameter.
  - > The feedback LED flashes green.  
The unit saves the value and goes to the next parameter.
- > After configuration of all LED segments the unit displays the current settings of all LED segments.
- ▶ Briefly press the parameter setting button (< 5 s) to finish the parameter setting mode.
  - > The feedback LED goes out. The unit is in the Run mode.

 If the parameter setting button is not pressed for longer than 30 seconds, the unit saves the last changes and goes to the Run mode.

## 9.2.1 Parameter structure

LED seg.	Parameter	Value								
		red	green	orange	blue	violet	turquoise	white	yellow	off
1	Colour	red	green	orange	blue	violet	turquoise	white	yellow	off
	Frequency	on	low flash rate slow	low flash rate medium	low flash rate fast	high flash rate slow	high flash rate medium	high flash rate fast		
	Brightness	100 %	75 %	50 %	25 %					
2	Colour	red	green	orange	blue	violet	turquoise	white	yellow	off
	Frequency	on	low flash rate slow	low flash rate medium	low flash rate fast	high flash rate slow	high flash rate medium	high flash rate fast		
	Brightness	100 %	75 %	50 %	25 %					
3	Colour	red	green	orange	blue	violet	turquoise	white	yellow	off
	Frequency	on	low flash rate slow	low flash rate medium	low flash rate fast	high flash rate slow	high flash rate medium	high flash rate fast		
	Brightness	100 %	75 %	50 %	25 %					
4	Colour	red	green	orange	blue	violet	turquoise	white	yellow	off
	Frequency	on	low flash rate slow	low flash rate medium	low flash rate fast	high flash rate slow	high flash rate medium	high flash rate fast		
	Brightness	100 %	75 %	50 %	25 %					
5	Colour	red	green	orange	blue	violet	turquoise	white	yellow	off
	Frequency	on	low flash rate slow	low flash rate medium	low flash rate fast	high flash rate slow	high flash rate medium	high flash rate fast		
	Brightness	100 %	75 %	50 %	25 %					

# 10 Scale drawing

## 10.1 DVx500

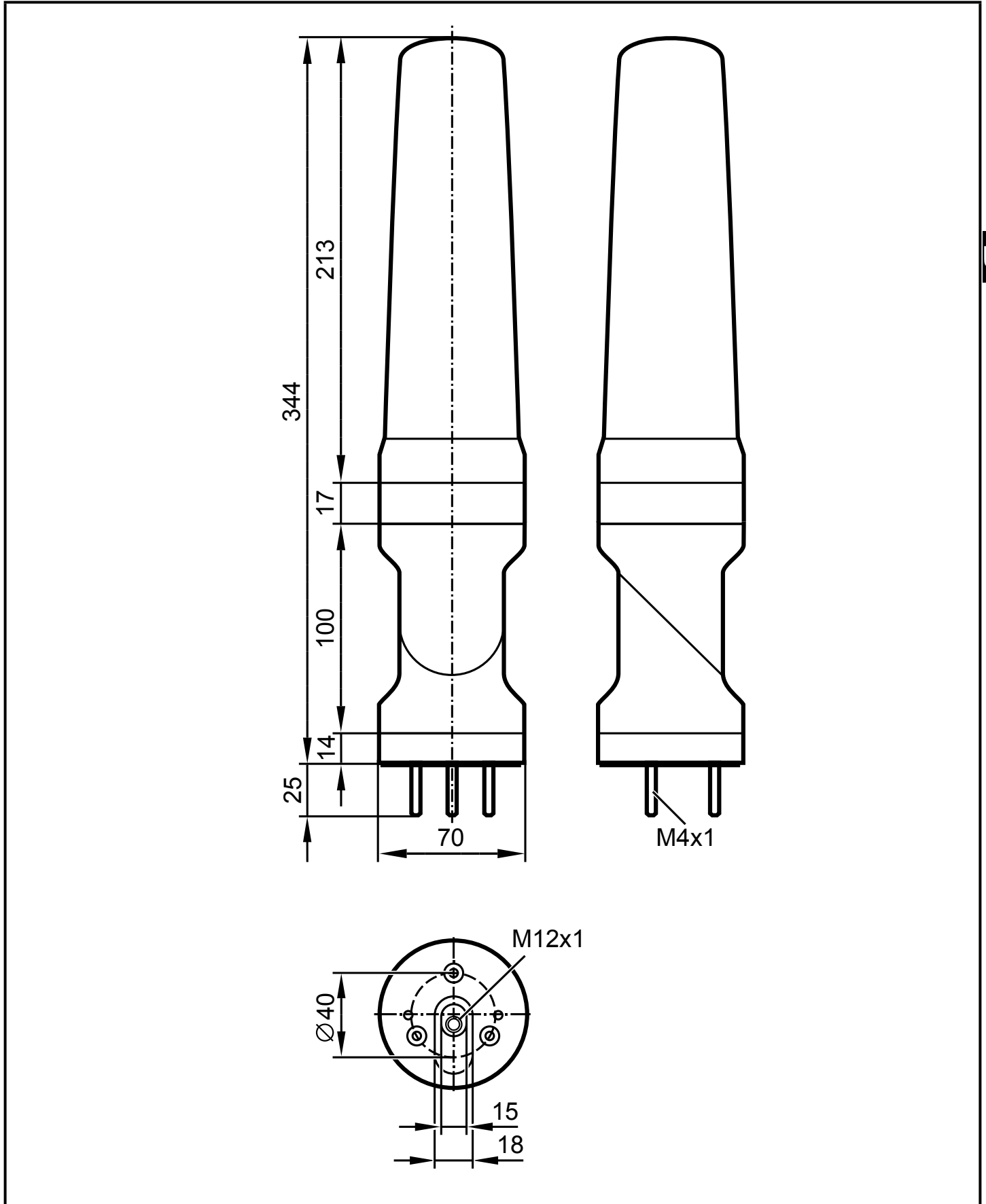

UK

Dimensions [mm]

## 10.2 DVx510

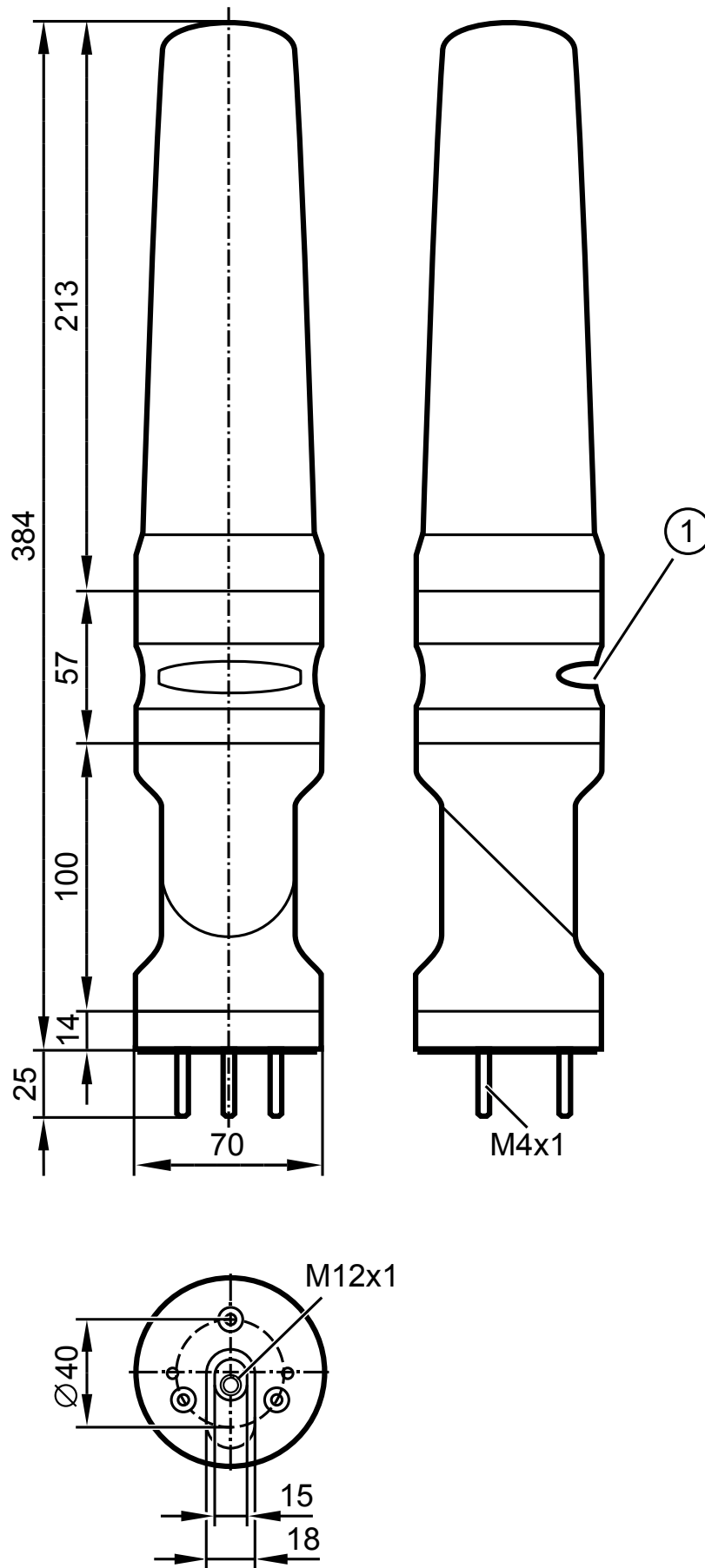

1: Buzzer

Dimensions [mm]

### 10.3 DVx520

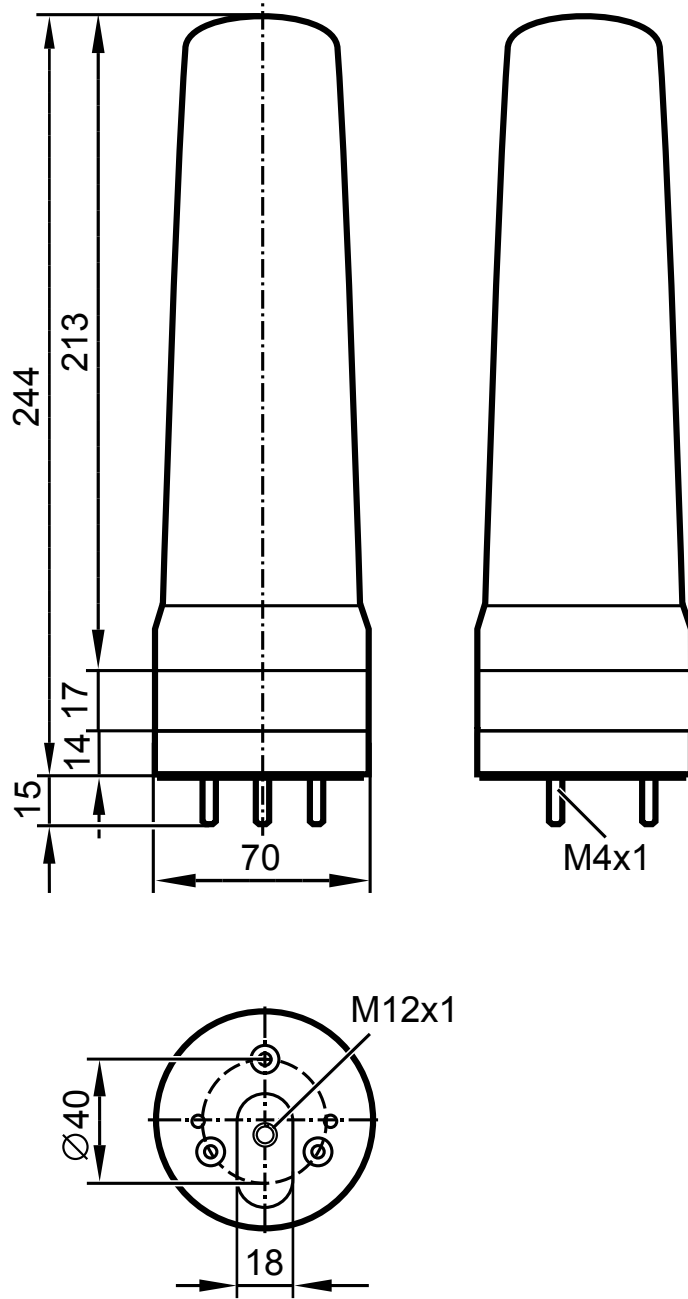

Dimensions [mm]

## 10.4 DVx530

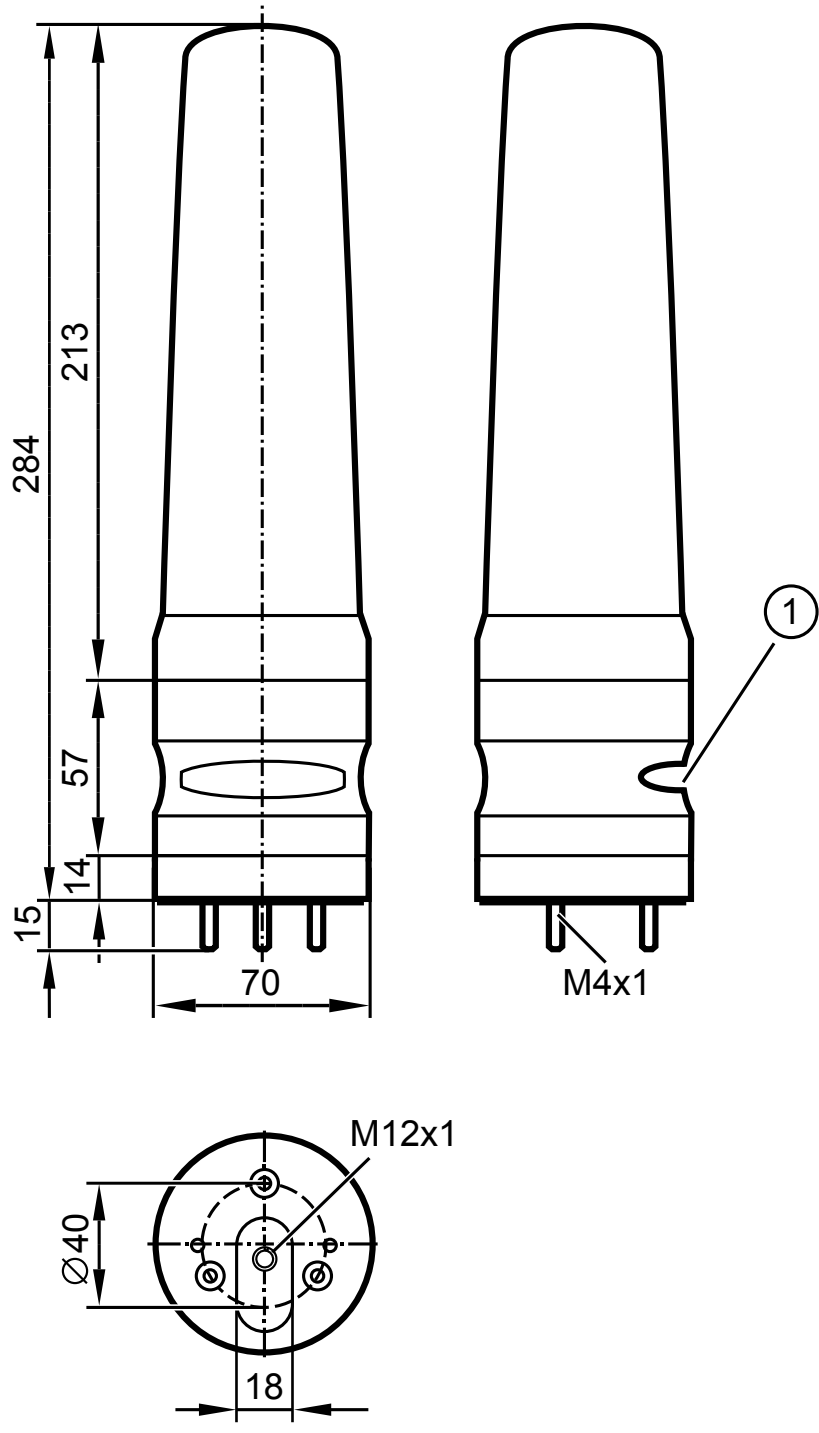

1: Buzzer

Dimensions [mm]

# 11 Technical data

		DV1500	DV1510	DV1520	DV1530	DV2500	DV2510	DV2520	DV2530
Operating voltage DC	[V]	18...30							
Nominal voltage DC	[V]	24							
Current consumption	[mA]	≤ 200 RMS (400 mA for 50 ms)							
Input current	[mA]	typ. 6 (24 V DC, high signal)							
Max. buzzer volume	[dB]	-	85	-	85	-	85	-	85
Degree of soiling		2							
Ambient temperature	[°C]	-25...50							
Storage temperature	[°C]	-40...75							
Max. permissible relative humidity	[%]	90							
Maximum operating altitude	[m]	2000 above sea level							
Permissible air pressure	[hPa]	1060							
IO-Link		-	-	-	-	●	●	●	●
Connectors		M12 connector, 8 poles				M12 connector, 4 poles			

UK

## 11.1 IO-Link device

Transmission type		COM2 (38.4 kbaud)
IO-Link revision		1.1
SDCI standard		IEC 61131-9
IO-Link device ID		
DV15xx		850 d / 00 03 52 h
DV25xx		841 d / 00 03 49 h
SIO mode		Yes
Input load current at input C/Q to V0 (ILL)	[mA]	< 250
Required master port type		A
Min. process cycle time	[ms]	3.2

## 12 Maintenance, repair and disposal

The unit is maintenance-free.

After use dispose of the unit in an environmentally friendly way in accordance with the applicable national regulations.

### 12.1 Cleaning the housing surface

- ▶ Disconnect the device.
- ▶ Clean the device from dirt using a soft, chemically untreated and dry cloth.
- ▶ In case of heavy dirt, use a damp cloth.



Micro-fibre cloths without chemical additives are recommended.

## 13 Approvals/standards

EC declarations of conformity, approvals, etc. at [www.ifm.com](http://www.ifm.com)