

General Specifications

Model SC42 and FF40/FS40/FD40
2/4-electrode design for Conductivity Flow fittings, Subassemblies and Immersion fittings

The measurement of specific conductivity in aqueous solutions is becoming increasingly important for the determination of impurities in water or the concentration measurement of dissolved chemicals. The accuracy of the measurement is strongly influenced by temperature variations, polarisation effects at the surface of the contacting electrodes, cable capacitances, etc.

Yokogawa provides sensors for pure water systems, general applications with a 2-electrode design and applications involving high concentrations of chemicals with a 4-electrode design.

To install conductivity sensors in a permanent or semi-permanent location, Yokogawa offers wide a range of flow and immersion fittings. A high degree of standardisation simplifies mounting, servicing and removal or replacement of the sensors.

Included are flow fittings and subassemblies for in-line or direct mounting of conductivity sensors in piping systems.

The immersion fittings are designed for tanks, open vessels or drains. PVC and stainless steel construction materials suit most process conditions, regarding chemical resistance, pressure and temperature specifications.

The fittings of stainless steel might be used in sanitary applications.



Features

- Wide range of sensors to suit most process conditions.
- High precision of the cell constant (Field calibration not necessary).
- Sensors for ultra-pure water applications.
- Built-in resistance thermometers Pt 1000 for automatic temperature compensation.
- Material certificate 3.1 according to EN 10024 for stainless steel sensors are always included.
- Optional quality inspection certificate.

System Configuration

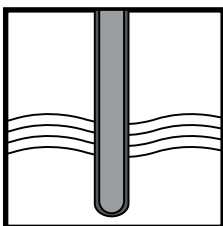

Sensors

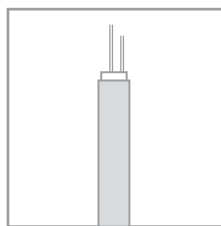

Cables

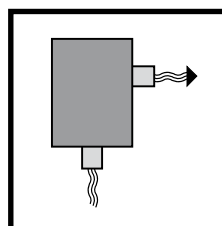

Fittings

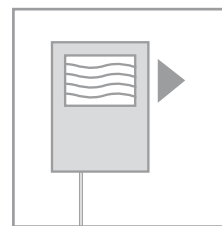

Transmitters

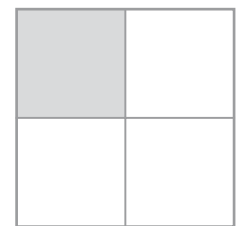

Accessories

Plug-in flow sensors (SS)

Stainless steel cells for 2-electrode type with cell constants 0.01 and 0.1 cm⁻¹.

These conductivity sensors have a stainless steel body and PEEK (Poly Ether Ether Ketone) inner insulation for high pressure/temperature applications. A special treatment of the electrodes ensures optimal resistance against polarisation. The sensor includes a built-in resistance thermometer Pt1000 for automatic temperature compensation.

The combination sensor plug and cable socket is watertight and temperature resistant up to 100°C (212 °F). It meets the requirements of IP65.

The dimensions of the sensor are standardised for mounting in the standard fitting program of Yokogawa.

Features

- High precision of the cell constant (individually calibrated).
- Fast temperature response.
- High pressure/temperature specifications.
- Built-in resistance thermometer, Pt1000 RTD
- Plug-socket cable connection for easy installation and maintenance, meeting IP 65.
- Standardised dimensions for mounting in flow- and immersion fittings
- Material certificate 3.1 according to EN 10014 are standard included (only wetted metal parts)

Typical Applications

1. Cell constant = 0.01 cm⁻¹

For measurement in very low conductive solutions like pure water, condensate, demineralised water, distilled water, etc.

2. Cell constant = 0.1 cm⁻¹

For measurement of low conductive solutions like boiler feed water, surface water, etc.

General Specifications

Materials

Wetted parts

- | | |
|------------------------|---------------------------------------|
| a. Body | : Stainless steel AISI 316 |
| b. Insulation | : PEEK (Poly Ether Ether Ketone) |
| c. Electrode | : Stainless steel AISI 316 |
| d. Quad-rings, O-rings | : Viton |
| e. Connector | : Polyamide with gold plated contacts |

Weight and immersion length (L in figure)

Model SC42-SP24	: 440 gram; 110 mm (L)
Model SC42-SP34	: 600 gram; 163 mm (L)

Functional Specifications

Model	Temp. element	Cell-constant	Pressure rating	Max. temperature	90% Temp. response	Measurement system
SC42-SP34	Platinum resistor (Pt1000 to DIN)	0.01 cm ⁻¹	10 bar/142 PSIG	150°C/302 °F	< 1 min.	2-electrode system
SC42-SP24	Platinum resistor (Pt1000 to DIN)	0.1 cm ⁻¹	10 bar/142 PSIG	150°C/302 °F	< 3 min.	2-electrode system

The maximum pressure and temperature rating also depend on the actual process conditions. Under certain circumstances it is necessary to test the cell in situ. Additional data is available from Yokogawa.

Note: Stainless steel cells for 2-electrode systems with cell-constants 0.01 and 0.1 cm⁻¹ designed for pressure and temperature ratings of up to 40 bar (PSIG) at 250°C (°F) are available upon request.

Options

Certificate /Q : Quality inspection certificate

GS 12D7J1-01E-E

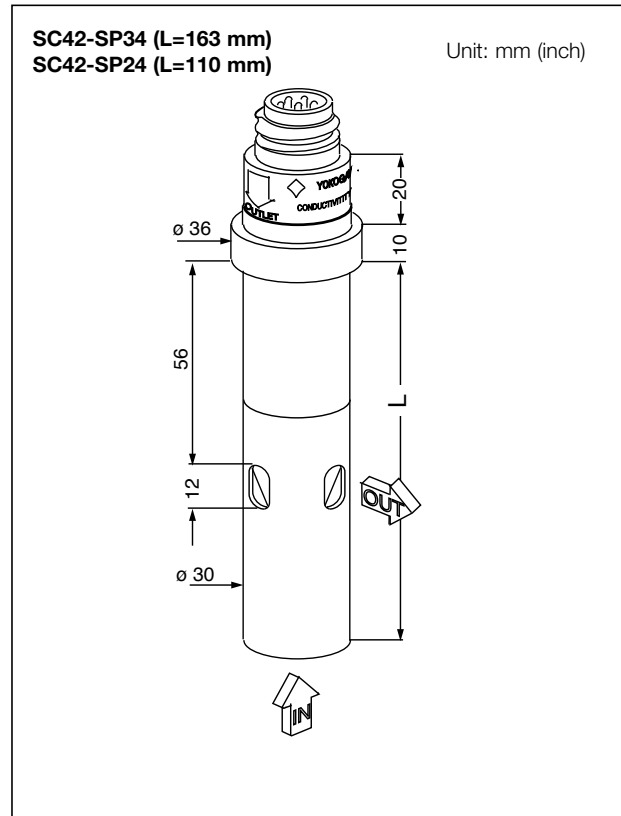

Figure 1 Flow type

Plug-in flow sensors (EPOXY)

Epoxy cells for 2- and 4-electrode type with cell-constants 1 and 10 cm⁻¹.

These conductivity sensors have a body of glass-filled epoxy resin. The electrodes are made from graphite impregnated with epoxy resin. This gives the sensors a good chemical resistance and a good reduction of polarisation effects.

Features

- Good chemical resistance.
- Choice in 2- and 4-electrode types.
- Easy installation

General Specifications

Materials

Wetted parts

- a. Body : Glass filled epoxy resin
- b. Electrodes : Graphite impregnated with epoxy resin

Connector plug : Polyamide with gold plated contacts

Weight and immersion length (L in figure)

- Model SC42-EP0. : 270 gram; 193 mm (L)
- Model SC42-EP1. : 220 gram; 160 mm (L)

Options

Certificate /Q : Quality inspection certificate

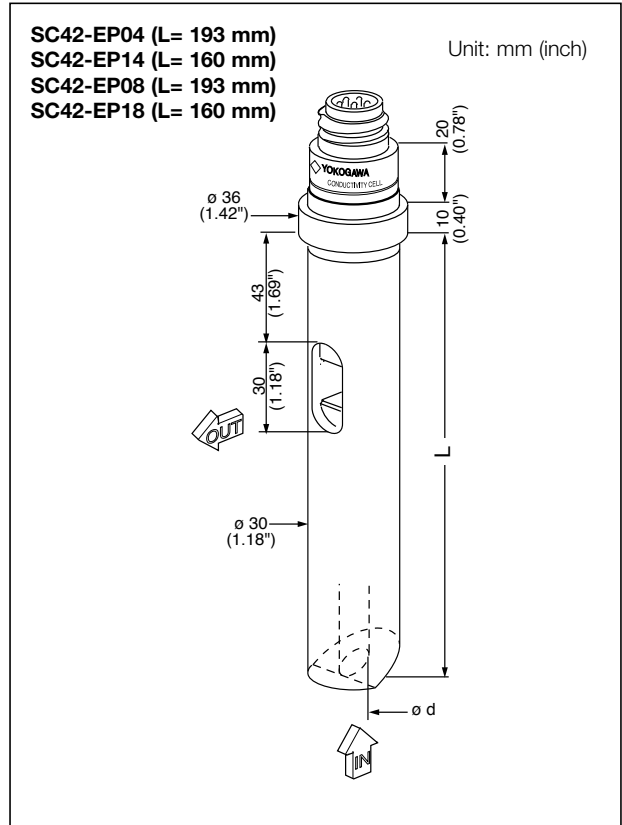

Figure 2 Flow type

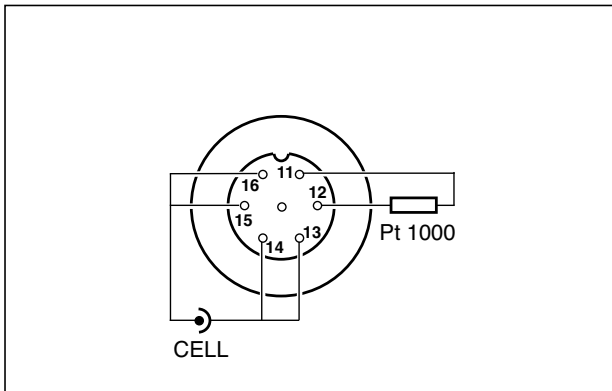

Figure 3 Connector 2-electrode system

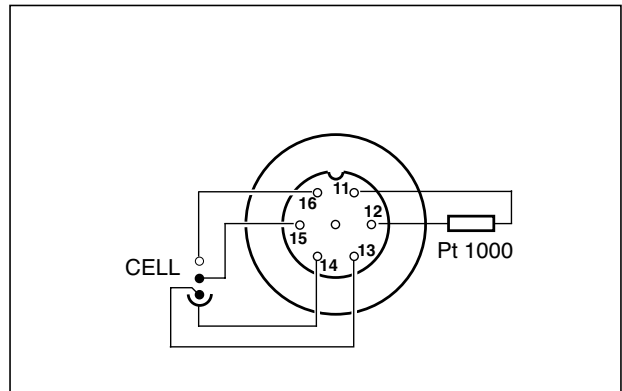

Figure 4 Connector 4-electrode system

Functional Specifications

Model	Temp. element	Cell constant	Pressure rating	Max. temperature	90% Temp. response	Inlet dø	Meas. system
SC42-EP04	Pt1000	10 cm ⁻¹	10 bar/142 PSIG	110°C/230 °F	< 3 min.	5 mm	2-el.ectrode
SC42-EP14	Pt1000	1 cm ⁻¹	10 bar/142 PSIG	110°C/230 °F	< 2 min.	10 mm	2-el.ectrode
SC42-EP08	Pt1000	10 cm ⁻¹	10 bar/142 PSIG	110°C/230 °F	< 3 min.	5 mm	4-el.ectrode
SC42-EP18	Pt1000	1 cm ⁻¹	10 bar/142 PSIG	110°C/230 °F	< 2 min.	10 mm	4-el.ectrode

The maximum pressure and temperature rating also depend on the actual process conditions. Under certain circumstances it is necessary to test the cell in situ. Additional data is available from Yokogawa.

Plug-in flow sensors (PTFE and PVDF)

PTFE or PVDF shielded glass-platinum cells for 2- and 4-electrode type with cell constant 10 cm⁻¹.

These conductivity sensors are excellent suited for measurement in aggressive media. The (protection) body consists of PVDF (Kynar) or PTFE (Teflon with 25% glass filling).

The cell itself is made from highly resistant glass with platinum electrodes. The electrodes surfaces of the 2-electrode cells (SC42-P04) are further enhanced by gold plating to minimize the polarisation effects.

The internal sealing between the glass measuring cell and the PTFE/PVDF body (not visible in drawing) is by a KALREZ O-ring (high quality with excellent chemical resistance). A VITON O-ring is supplied with the sensors for sealing the cell in the fitting (visible in drawing). For measurements in strongly oxidizing acids an optional KALREZ O-ring is recommended.

Features

- Excellent chemical resistance for applications in aggressive media like oleum, concentrated mineral acids, etc.
- Suitable for measurement of highly conductive, strongly polluted solutions.
- Optimum results by gold plating (of 2-electrode version) against polarisation effects.

Typical applications

- PTFE-cell : Concentrated mineral acids such as: oleum, nitric acid, hydrochloric acid, etc.
- PVDF-cell : All aggressive media with the exception of strongly oxidizing agents.

Note: See the chemical resistance list in table 1.

General specifications

Materials

Wetted parts

- a. Body (shield) : - PVDF (Kynar®) for model SC42-FP04/FP08.
- PTFE (Teflon® with 25% glass) for model SC42-TP04/TP08
- b. O-ring : - KALREZ™ for cell-body sealing
- VITON™ for sealing in het fitting
- c. Electrodes system : Platinum, Gold plated for 2-electrode
- d. Inside cell : Glass tube
- e. Connector plug : Polyamide with gold plated contacts

Functional Specifications

Model	Temp. element	Cell-constant	Pressure rating	Max. temperature	90% Temp. response	Measurement system
SC42-FP04	PT1000	10 cm ⁻¹	10 bar/142 PSIG	110°C/230 °F	< 1 min.	2-electrode system
SC42-TP04	PT1000	10 cm ⁻¹	2 bar/28,5 PSIG	110°C/230 °F	< 1 min.	2-electrode system
SC42-FP08	PT1000	10 cm ⁻¹	10 bar/142 PSIG	110°C/230 °F	< 1 min.	4-electrode system
SC42-TP08	PT1000	10 cm ⁻¹	2 bar/28,5 PSIG	110°C/230 °F	< 1 min.	4-electrode system

The maximum pressure and temperature rating also depend on the actual process conditions. Under certain circumstances it is necessary to test the cell in situ. Additional data is available from Yokogawa.

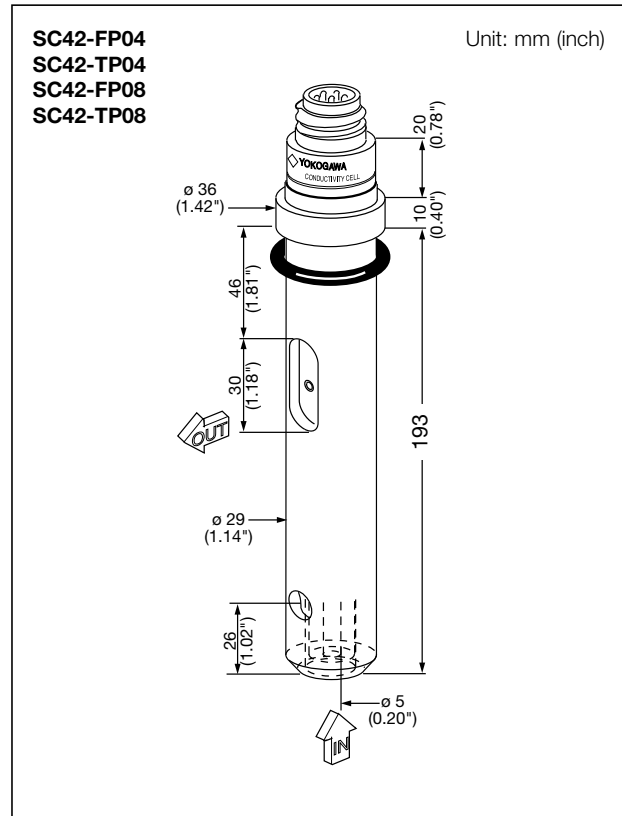

Figure 5 Flow type

Weight and immersion length

- Model SC42-FP0 : ca. 270 gram; 193 mm
Model SC42-TP0 : ca. 320 gram; 193 mm

Warning:

Temperature shocks should be avoided

Options

- Certificate /Q : Quality inspection certificate

Insertion Sensors

Insertion sensors for 2-electrode type with cell constant 1cm⁻¹.

The insertion sensors are especially useful in applications where a representative sample flow through the sensor cannot be achieved easily (e.g. in liquids containing solids, direct measurement in pipe-lines). The electrode surfaces are easily accessed for cleaning or maintenance. The model SC4.-EP15D is especially designed for direct mounting in sanitary piping systems. It has a collar piece suitable for mounting with DN 25.

Features

- No obstacles in the flow-line by short immersion length.
 - Easy cleaning.
 - Good chemical resistance.
 - Low polarisation distortion.
- In addition to that the model SC42-EP15D can be directly fitted with a DN25 swivel.

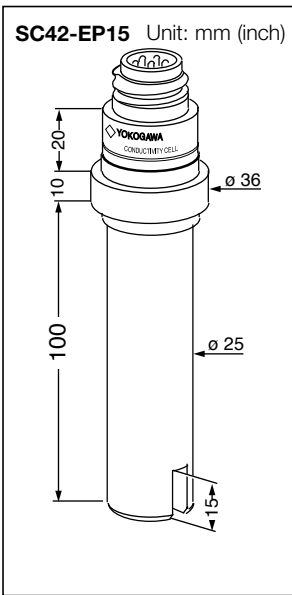

Figure 6 Insertion type

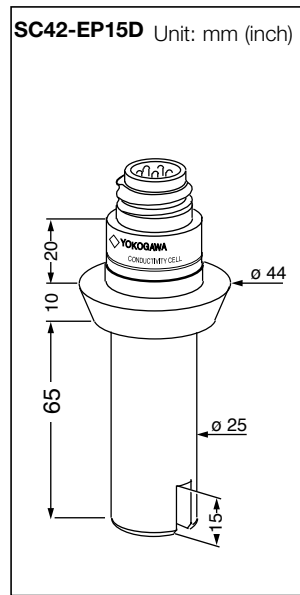

Figure 7 Insertion type (sanitary)

Applications

For measurement of moderate conductive solutions like surface water, waste water, salt solutions, etc.

General Specifications

Materials

Wetted parts

- Body : Glass-filled epoxy resin
- Electrodes : Graphite impregnated with epoxy
- Connector plug : Polyamide with gold plated contacts

Weight and immersion length (L in figure)

- Model SC42-EP15 : 150 gram; 100 mm
- Model SC42-EP15D : 150 gram; 65 mm

Options

Certificate /Q : Quality inspection certificate

Functional Specifications

Model	Temp. element	Cell-constant	Pressure rating	Max. temperature	90% Temp. response	Measurement system
SC42-EP15	Pt1000	1 cm ⁻¹	10 bar/142 PSIG	110°C/230 °F	< 3 min.	2-electrode system
SC42-EP15D	Pt1000	1 cm ⁻¹	10 bar/142 PSIG	110°C/230 °F	< 3 min.	2-electrode system

The maximum pressure and temperature rating also depend on the actual process conditions. Under certain circumstances it is necessary to test the cell in situ. Additional data is available from Yokogawa.

Parts and Accessories

To connect the conductivity sensors to a transmitter or converter Yokogawa supplies special cables already pretreated and equipped with numbers for easy connection to Yokogawa instruments.

Model	Description	Length
WU40-LH01	Conductivity cable	1.0 m
WU40-LH02	Conductivity cable	2.0 m
WU40-LH05	Conductivity cable	5.5 m
WU40-LH10	Conductivity cable	10 m
WU40-LH15	Conductivity cable	15m
WU40-LH20	Conductivity cable	20 m
WU40-LH25	Conductivity cable	25 m

- K1500FX Set of 5 O-rings for sealing the cell in the fitting material: silicone rubber.
- K1500AG Set of 5 O-rings for sealing the cell in the fitting material: VITON™.
- K1500AH One (1) KALREZ™ O-ring for sealing the cell in the fitting.

Selection Criteria

A good indication of construction materials can be taken from the piping material used in the process equipment. If this material of better is used no problems by corrosion will occur.



In considering the required sensor, please check all four points listed hereafter:

- The pressure and temperature requirements are within the limits of the cell.
- The selected materials (wetted parts) have a good resistance to corrosion according to practice or table 2.
- The conductivity value at the process temperature is within the application range of the cell (see figure 1).
- A selection is made between 2- or 4-electrode measuring system (see figure 1).

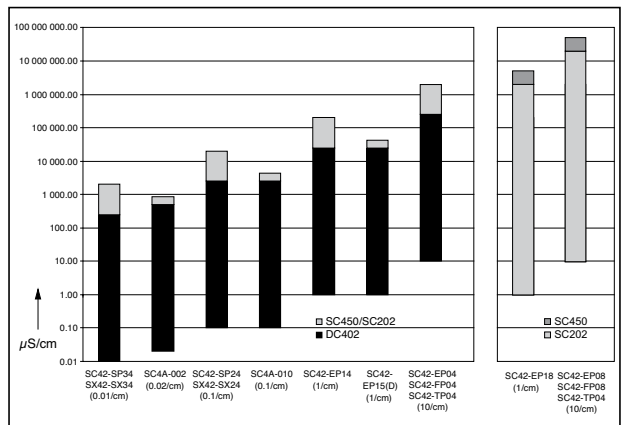

Figure 8 Range ability of conductivity sensors

Model FF40/FS40 flow fittings and subassemblies for conductivity measuring loops

To install conductivity sensors in a permanent or semi-permanent location, the program of Yokogawa includes a range of flow and immersion fittings.

A high degree of standardisation simplifies mounting, servicing and removal or replacement of the sensors.

The program includes flow fittings and their subassemblies for in-line or direct mounting of conductivity sensors in piping systems.

A wide choice of construction materials gives the user the best solution for any process considering chemical resistance, pressure and temperature specifications.

Features

- Wide choice of construction materials.
- High degree of standardisation for all cells.
- Easy mounting, service and removal of sensors.
- Electrolytically polished stainless steel designs for optimal corrosion resistance.
- Available with flange adapters.

A. Flow Fittings

From a practical plant aspect, the best mounting place of a conductivity sensor is in a by-pass with a sample valve. For these applications the flow fittings are ideal.

Features

- Easy mounting and maintenance of the sensors.
- Changeable liquid outlet position (right or left).
- Wall mounting bracket.
- Blanking plug for mounting and test applications.

General Specifications

Materials

Wetted parts

- Body
 - Model FF40-V22 : Polyvinylchloride (PVC)
 - Model FF40-S22 : Stainless steel AISI 316 (SS)
 - Model FF40-P22 : Polypropylene (PP)
 - O-rings : Silicone rubber
- Mounting brackets for
- Model FF40-V22 : Polypropylene (PP)
 - Model FF40-S22 : Polamide (PA)
 - Model FF40-P22 : Polypropylene (PP)
- Retaining nut for
- Model FF40-V22 : Polyvinylchloride (PVC)
 - Model FF40-S22 : Stainless steel AISI 304 (SS)
 - Model FF40-P22 : Polypropylene (PP)

Volume measuring vessel

- Plastic fittings : Approx. 150 ml
- Stainless steel fitting : Approx. 150 ml

Mounting connections

- Plastic fittings : For screw M6
- Stainless steel fitting : 2x M8 (female)

Process connections

- PVC fitting : PVC tube \varnothing 12 O.D.
- PP fitting : 1/2" - NPT (female)
- SS fitting : 1/2" - NPT (female)
- Flange (option) : 1/2" ANSI 150 lbs or DN 15 PN10

Weight

- Model FF40-V22 : 770 gram
- Model FF40-S22 : 550 gram
- Model FF40-P22 : 530 gram

Functional Specifications

Temperature

- Min. : -10°C
- Max. : Depending on material and application (see fig. 2)

Flow rate

- : 0,1 - 10 l/min (depending on application)

Pressure

- : See fig. 2

Dimensions

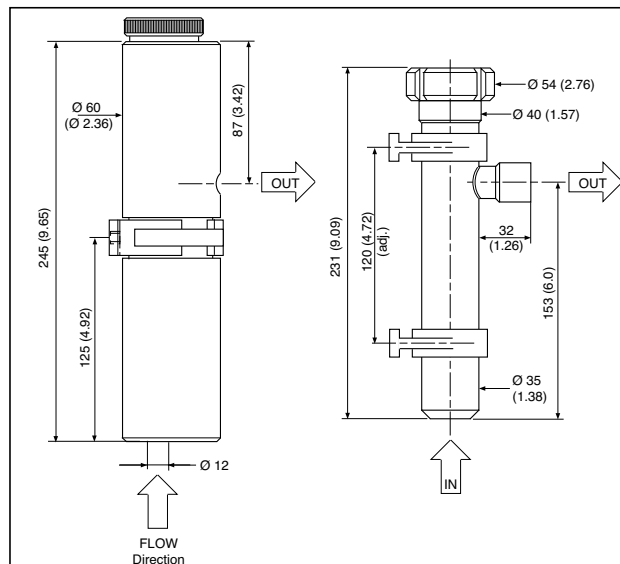

Figure 9 Flow Fittings

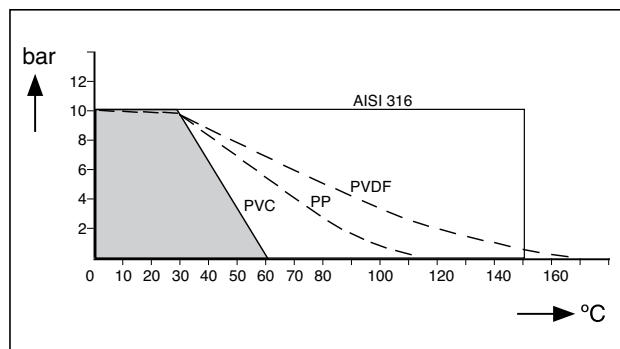

Figure 10 Pressure/temperature class

Model and Suffix Codes

Model	Suffix	Option	Description
FF40			Flow fitting
Material	-P22 -S22 -V22		Polypropylene Stainless steel Polyvinylchloride
Options Flange adapters (NPT 1/2" Male lap joint)	/FP1 /FP2 /FP3 /FP4 /FS1 /FS2 /FS3 /FS4		DN15 PN10 PP DN25 PN10 PP 1/2" ANSI 150lbs PP 1" ANSI 150lbs PP DN15 PN10 SS AISI 316 DN25 PN10 SS AISI 316 1/2" ANSI 150lbs AISI 316 1" ANSI 150lbs AISI 316
Certificate	/M		Material certificate 3.1 according to EN 10024 (For SS wetted parts only)

Spare Parts

Part no.	Description
K1500AK	O-rings EPDM 29.74x3.53 (5)
K1500EG	Mounting clampset for FF40-S22
K1500EH	Mounting clamp for FF40-P/V22
K1500FX	O-rings Sil 70 29.74x3.53 (5)
K1521AD	Flange adapter /FS3
K1521AF	Flange adapter /FP3
K1521AG	Flange adapter /FS4
K1521AJ	Flange adapter /FP4
K1521AK	Flange adapter /FS1
K1521AM	Flange adapter /FP1
K1521AN	Flange adapter /FS2
K1521AQ	Flange adapter /FP2

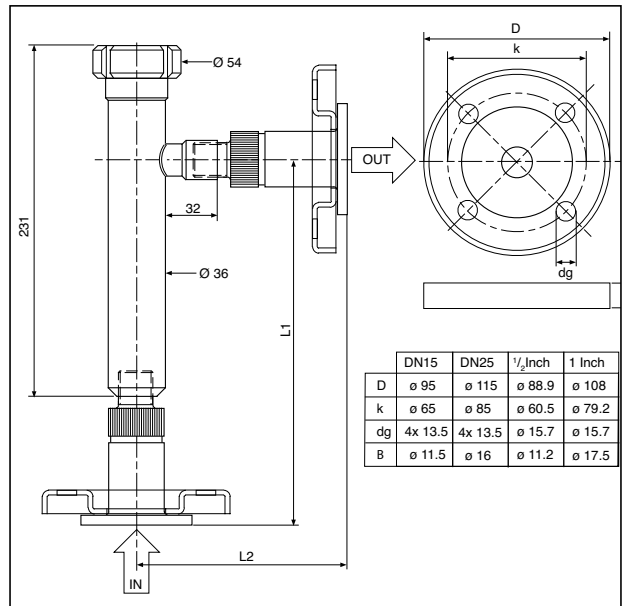

Figure 11 Dimensions of Flange options

Type	DN15PN10		DN25-PN10		1/2" 150 lbs		1" 150 lbs	
	L1	L2	L1	L2	L1	L2	L1	L2
FF40-S22	226	123	236	133	8 7/8"	4 13/16"	9 5/16"	5 1/4"
FF40-P22	247	123	236	112	9 3/4"	4 7/8"	9 5/16"	4 7/16"

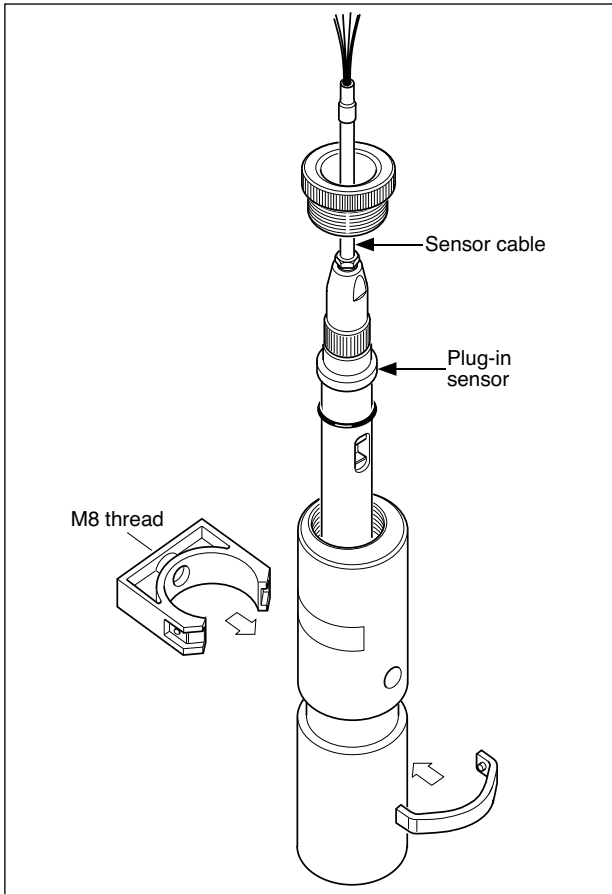

Figure 12 PVC/PP flow fitting

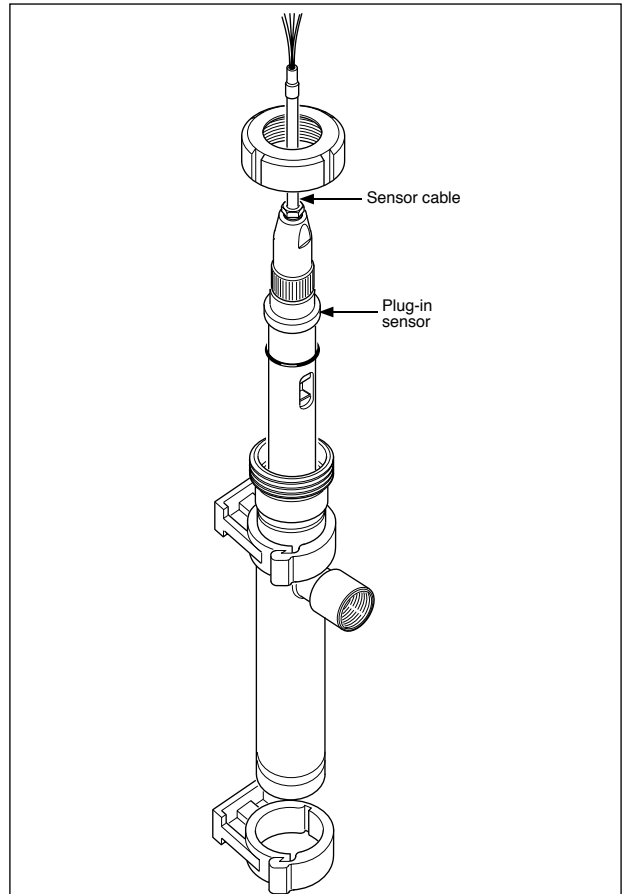

Figure 13 Stainless steel flow fitting

B. Subassemblies

The subassemblies are designed for mounting conductivity sensors in a tank wall or directly into a piping system. They can be easily mounted in the process piping by welding, cementing or screwing.

The stainless steel subassemblies meet the requirements of DIN 11850 and DIN 11851 for sanitary constructions.

Features

- Suitable for mounting in a T-piece or directly in the piping system.
- Designs for mounting the plug-in type sensor and the insertion type sensor with collar piece DN 25 (D-model).

General Specifications

Materials

Wetted parts

a. Body

Model FS40-S22-WE	: Stainless steel AISI 316 (SS)
Model FS40-S22-TP	: Stainless steel AISI 316 (SS)
Model FS40-S23-DF	: Stainless steel AISI 316(SS)
Model FS40-F22-PA	: Polyvinylidene fluoride (PVDF)
Model FS40-F22-TP	: Polyvinylidene fluoride (PVDF)
Model FS40-V22-WE	: Polyvinylchloride (PVC)
Model FS40-V22-TP	: Polyvinylchloride (PVC)

b. Sealing ring

Silicone rubber	: DIN/ISO 1629 code VMQ
Buna N	: DIN/ISO 1629 code NBR
Perfluorelastomer	: DIN/ISO 1629 code PFFPM

Process connections

Model FS40-S22-WE	: DN32
Model FS40-S22-TP	: 1 ¹ / ₄ "- 11,5 NPT
Model FS40-S23-DF	: DN25
Model FS40-F22-PA	: ISO 228/1 - G 1 ¹ / ₄ " (BSPP)
Model FS40-F22-TP	: 1 ¹ / ₄ "- 11,5 NPT
Model FS40-V22-WE	: DN32
Model FS40-V22-TP	: 1 ¹ / ₄ "- 11,5 NPT

Weight

Model FS40-S22-WE	: 0.21 kg
Model FS40-S22-TP	: 0.30 kg
Model FS40-S23-DF	: 0.13 kg
Model FS40-F22-PA	: 0.10 kg
Model FS40-V22-WE	: 0.45 kg
Model FS40-V22-TP	: 0.12 kg
Model FS40-F22-PA	: 0.13 kg

Functional Specifications

Temperature

Min.	: -10°C (14 °F)
Max.	: Depending on material (see fig. 2)

Pressure : See fig. 2

Model and Suffix Codes

Model	Suffix code	Option code	Description
FS40			Flow fitting subassembly
Material	-F22 -S22 -V22 -S23		Polyvinylidene fluoride (PVDF) Stainless steel (SS) Polyvinylchloride (PVC) Stainless steel D-Model (SS)
Mounting	-WE -PA -TP -DF		Weld-in socket for S version Glue-in socket for V version. Parallel thread, only for PVDF version (ISO 2281- G1 ¹ / ₄ ") Tapered pipe thread (1 ¹ / ₄ " NPT) For insertion type sensor with collar piece DN25 only (only for S23)
Certificate	/M		Material certificate 3.1 according to EN 10024 (only wetted metal parts)

Spare Parts

Part no.	Description
K1500AH	O-ring Kalrez 29.74x3.53
K1500AR	O-rings Sil 70, FS40-F22-PA (5x)
K1500FX	O-rings Sil 70 29.74x3.53 (5)
K1500HE	O-ring set silicon, FS40-S23

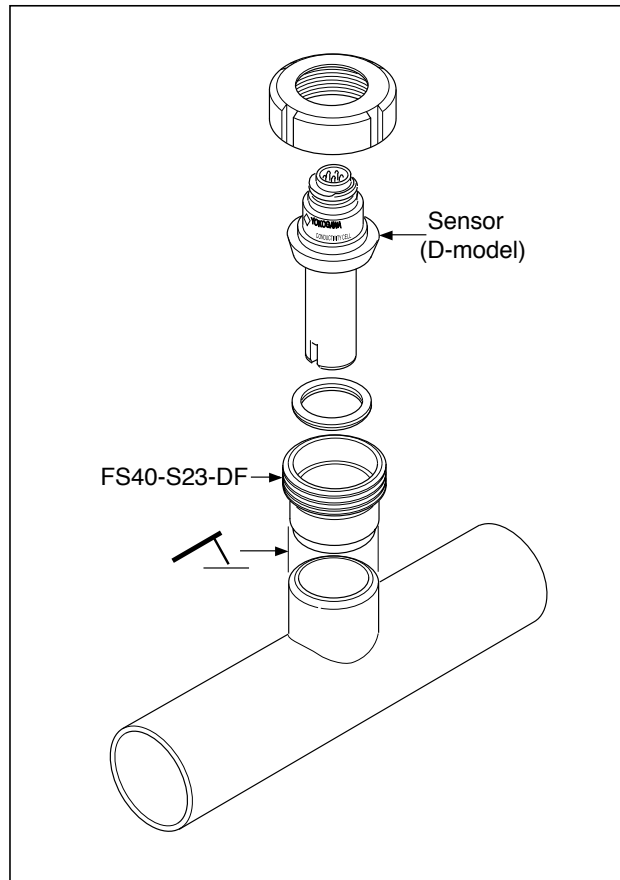

Figure 14 Installation example

Dimensions

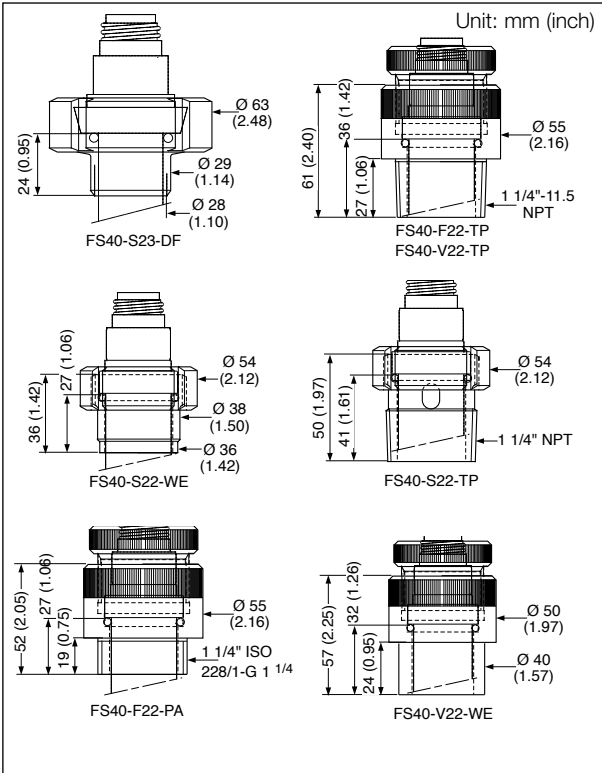

Figure 15 Flow Fittings subassembly

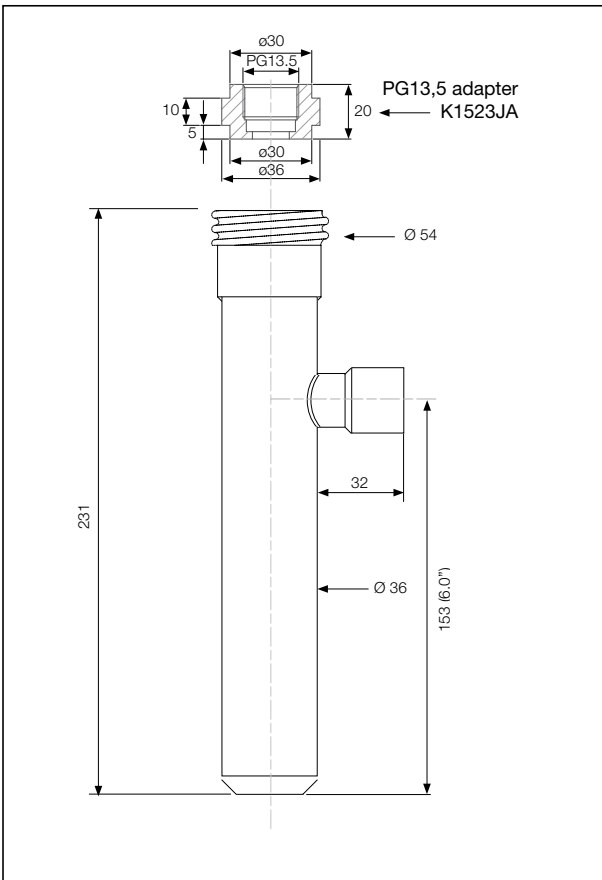

Figure 16 Description K1523JA

Description: Adapter to fit sensors with a PG13,5 process connection in FF40/FS40 and FD40 fittings. Material: Polypropylene

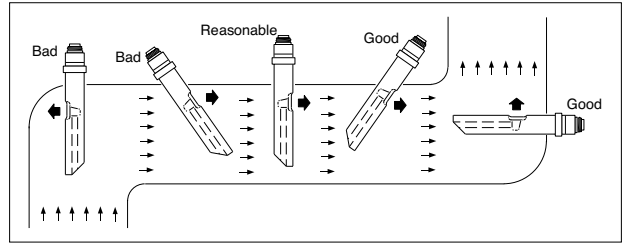

Figure 17 Mounting position sensors

Accessories and Options

Type	Description
WF10	Connecting cable (between connecting box and transmitter)
WU40-LH01	Sensor cable (1 m)
WU40-LH02	Sensor cable (2 m)
WU40-LH05	Sensor cable (5,5 m)
WU40-LH10	Sensor cable (10 m)
WU40-LH15	Sensor cable (15 m)
WU40-LH20	Sensor cable (20 m)
WU40-LH25	Sensor cable (25 m)

Service Parts

Type	Description
K1500AR	Silicone O-rings (42.52 x 2.62) for PVDF subassembly (qty. 5)
K1500HE	Sealing rings (29.74 x 3.53) for SS subassembly (D-model)
K1500FX	Silicone O-rings (29.74 x 3.53) for other fittings and subassemblies (qty. 5)
K1500AH	Perfluorelastomer O-ring (Kalrez) (29.74 x 3.53) for fittings and subassemblies (optional), except for the DF style (qty. 1)
K1500AK	EPDM O-rings (29.74 x 3.53) for fittings and subassemblies (optional), except for the DF model (qty. 5)

Ordering Instructions

When ordering, specify model and code, item name and part no.:

- Flow fitting : FF40-P22, FF40-S22 or FF40-V22
- Subassembly : FS40-F22-..., FS40-S22-..., FS40-V22-... (flow fitting) or FS40-S23-DF
- Sensor cable, : WU40-LH01, WU40-LH02, WU40-LH05, WU40-LH10 if relevant WU40-LH15, WU40-LH20 and WU40-LH25.
- Connecting box/connecting cable (only when converter is installed a distance from the fitting) : BA10/WF10 or BP10/WF10 (IS Design)
- Accessories : Part name and part number (quantity)
- Service parts : Part name and part number (quantity)

Model FD40 Immersion Fittings for conductivity measuring loops

For installing conductivity sensors in a permanent or semi-permanent location, the program of Yokogawa includes a range of flow and immersion fittings.

The immersion fittings are for installing conductivity sensors in tanks, open vessels or drains. The constructions of PVC and stainless steel suit most process conditions, considering chemical resistance, pressure and temperature specifications. The fittings of stainless steel might be used in sanitary applications. A mounting flange can be ordered.

Features

- Designed for mounting conductivity sensors in tanks, open vessels and drains.
- Easy mounting, service and removal or replacement of sensors.
- High pressure and temperature specifications.
- With or without flanged connection.
- Stainless steel construction for sanitary applications.
- Several lengths available.

From a practical plant aspect, the immersion fittings should be installed in a site, where the point of measurement truly represents the entire solution. Avoid areas where the measurement varies significantly. If the fitting is mounted in a tank with agitator, or if it is placed in a fast flowing process, care must be taken that the fitting is adequately supported. Select a mounting place where the sensor is always immersed in the process liquid.

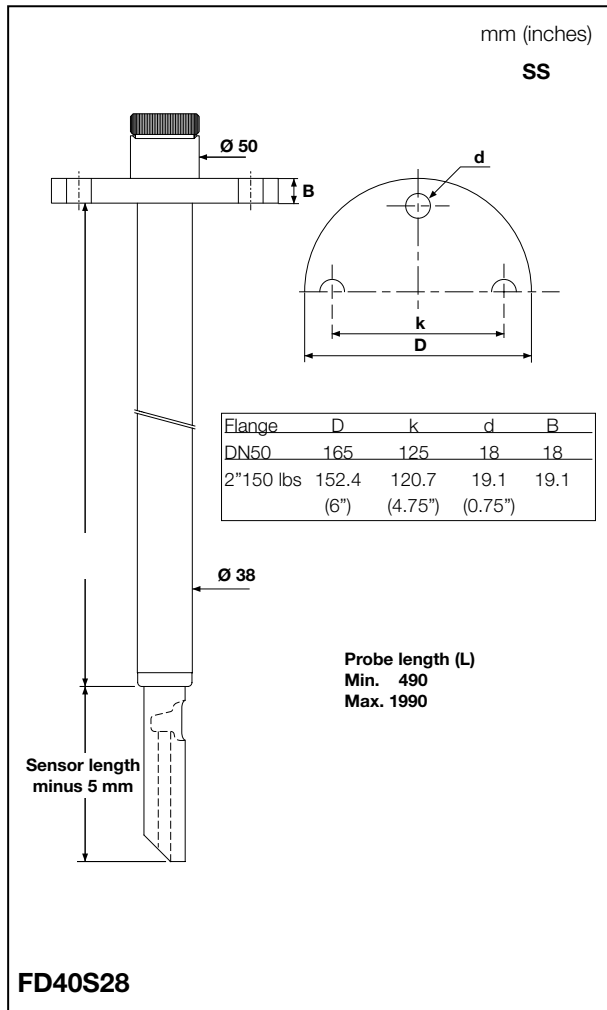

GS 12D7J1-01E-E

General Specifications

- Wetted parts**
- a. Body** : Stainless steel AISI 316 (SS)
Polyvinylchloride (PVC)
(refer to model code)
- b. O-rings** : Silicone rubber (other materials see accessories)
- Sensor cable** : Six wire multicore, covered with thermoplastic PVC
length: 5.5 m or 10 m
- Blanking plug*** : Ryton R4
- Weight (without flange)** : a. PVC fitting 1.7 kg
b. SS fitting 4.5 kg

* This plug is for test applications only and must be removed before mounting the sensor.

Functional Specifications

- Temperature**
- Min. : -10°C (14 °F)
Max. : Depending on material and application (see fig. 3)
- Pressure** : See fig. 3

Immersion length fitting : 0.5 to 2.0 m (in steps of 0.1 m)

Spare Parts

Part no.	Description
K1500AB	Cable gland 1/2 inch NPT (10)
K1500AK	O-rings EPDM 29.74x3.53 (5)
K1500AW	Flexible conduit, 5 meter
K1500AX	Flexible conduit, 10 meter
K1500AY	Connection parts for conduit
K1500EM	/PH25 for immersion holders
K1500DN	/PH03 protection hose, 3 meter
K1500DP	/PH05 protection hose, 5 meter
K1500DQ	/PH10 protection hose, 10 meter
K1500DR	/PH15 protection hose, 15 meter
K1500DS	/PH20 protection hose, 20 meter

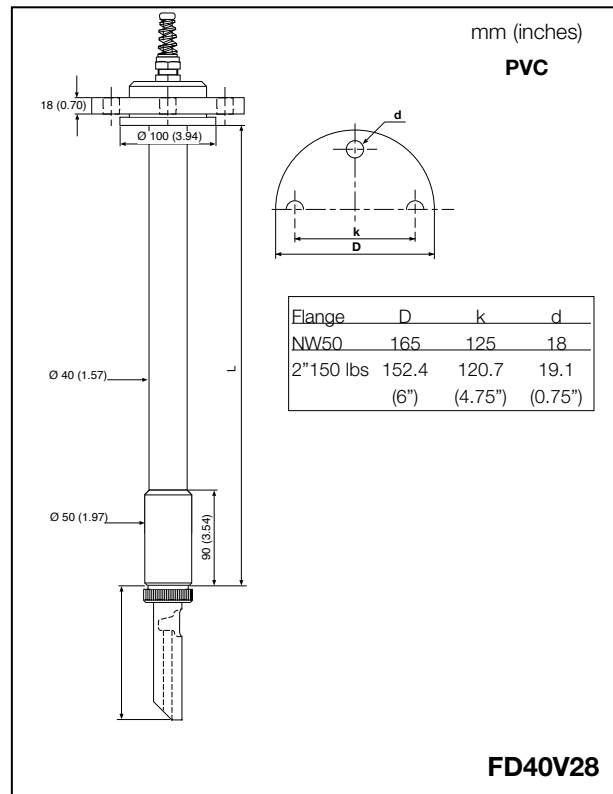

Model and Suffix Codes

Model	Suffix	option	Description
FD40V28 (f1, f2)			Immersion fitting PVC
FD40S28 (f3, f4)			Immersion fitting Stainless steel
Immersion	-□□		Between 0.5 and 2.0 m length (in dm) example:=-06 m
		-NC	No cable
		-FN	No flange
		-F1	PVC flange DN50 PN10
		-F2	PVC flange ANSI 2" 150 lbs
		-F3	SS flange DN50 PN10 (AISI 316)
		-F4	SS flange ANSI 2" 150 lbs (AISI 316)
		*B	Style code B
Protection hose	/PH5		For 5,5 m cable
Mounting kit	/PH10		For 10 m cable
Cable	/C05		(Length 5.5 m)
	/C10		(Length 10 m)
Certificate	/M		Material certificate 3.1 according to EN 10024 (on wetted metal parts only)

Ordering Instructions

When ordering, specify model and code, item name and part numbers:

1. Immersion fitting : FD40V28 or FD40S28
2. Sensor cable, if relevant : WU40-LH05 or WU40-LH10
3. Connecting box/connecting cable (only when converter is installed a distance from the fitting) : BA10/WF10
4. Accessories : Part name and part number (quantity)
5. Service parts : Part name and part number (quantity)

Accessories and Options

Type	Description
BA10	Connection box (between fitting and transmitter)
WF10	Connecting cable (between connecting box and transmitter)
WU40-LH05	Sensor cable (5,5 m)
WU40-LH10	Sensor cable (10 m)
K1500CJ	/PH05 cable protection
K1500CK	/PH10 cable protection
K1500DN	/PH03 protection hose, 3 meter
K1500DN	/PH05 protection hose, 5 meter
K1500DN	/PH10 protection hose, 10 meter
K1500DN	/PH15 protection hose, 15 meter
K1500DN	/PH20 protection hose, 20 meter

Service Parts

Type	Description
K1500FX	5x O-rings for mounting the sensor in a fitting
K1500FY	5x O-rings (Silicone) for sealing the cell
K1500AH	1x O-rings (KALREZ)
K1541ZY	/MS1 for FD30 / ISC40FD and FD40

* Special material for use in aggressive mediums.

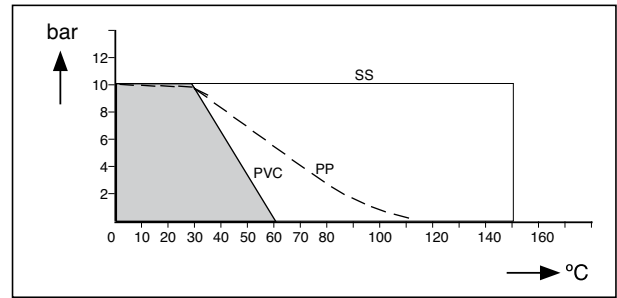

Figure 18 Pressure/temperature class

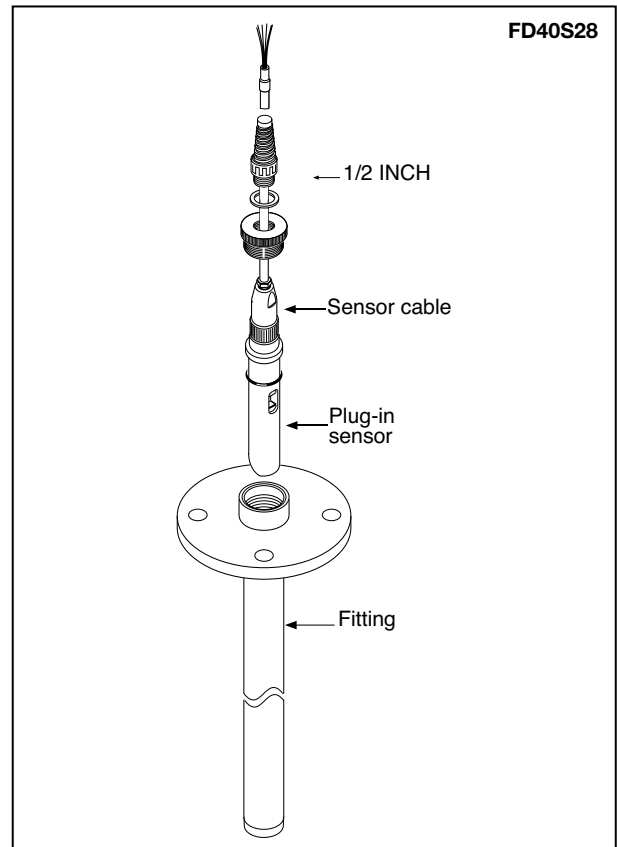
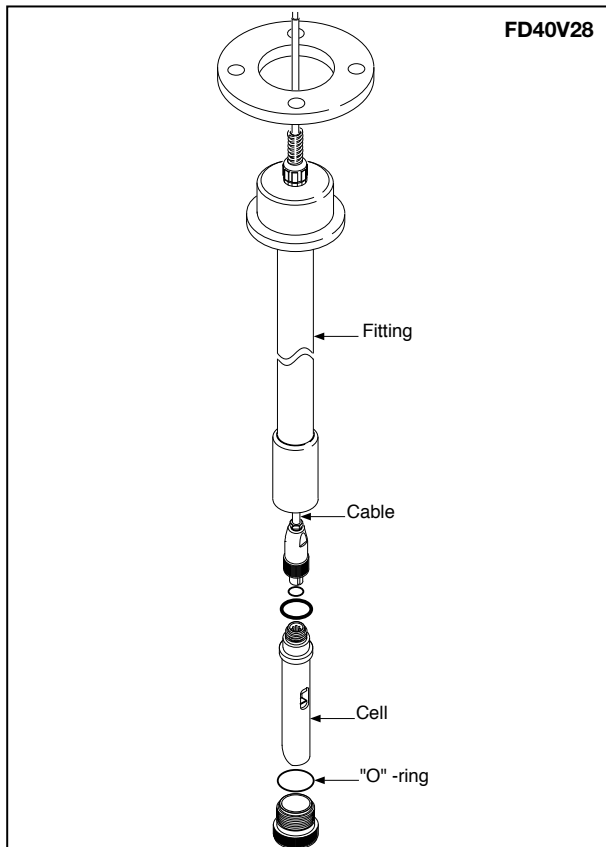



Table 1

		Material									
		PTFE (teflon)	PVDF (Kynar)	S.S. 316	EPOXY	VITON	GLASS	PEEK	KALREZ	SILICONE RUBBER	
		Temp. °C % Conc.	20 60 100	20 60 100	20 60 100	20 60 100	20 60 100	20 60 100	20 60 100	20 60 100	20 60 100
Inorganic acid	Sulfuric acid	10	000	000	XXX	OXX	000	000	000	000	000
		50	000	000	XXX	XXX	000	000	00X	000	- - -
		95	000	OX -	XXX	- - -	000	000	- - -	000	- - -
		fuming	000	- - -	- - -	- - -	000	000	- - -	000	- - -
	Hydrochloric acid	10	000	000	- - -	OX -	000	000	00X	00X	
		sat.	000	000	- - -	OX -	000	000	00X	00X	
	Nitric acid	25	000	00X	XXX	OX -	00X	000	000	000	00X
		50	000	00X	XXX	X - -	- - -	000	XXX	000	X - -
		95	000	OX -	000	- - -	- - -	000	- - -	00X	- - -
	fuming	000	- - -	000	- - -	- - -	000	- - -	00X	- - -	
		25	000	000	- - -	00X	000	000	000	000	00X
		50	000	000	XXX	00X	000	000	000	000	00X
95	000	000	000	00X	XX -	000	000	000	000	OXX	
	fuming	000	- - -	000	- - -	- - -	000	- - -	00X	- - -	
Phosphoric acid	25	000	000	- - -	00X	000	000	000	000	00X	
	50	000	000	XXX	00X	000	000	000	000	00X	
	95	000	000	000	00X	XX -	000	000	000	OXX	
Hydrofluoric acid	40	000	000	- - -	XX -	000	XXX	- - -	00X		
	75	000	000	- - -	XX -	000	- - -	- - -	00X		
Organic acid	Acetic acid	10	000	000	00X	00X	- - -	000	000	000	000
		glacial	000	OX -	00X	X - -	- - -	000	00X	000	000
	Formic acid	80	000	000	XXX	X - -	- - -	000	XXX	00X	000
	Citric acid	50	000	000	000	X - -	000	000	000	000	000
Alkali	Calcium hydroxide	sat.	000	000	000	000	000	000	000	000	000
	Potassium hydroxide	50	000	00X	000	00X	000	00X	000	000	000
	Sodium hydroxide	40	000	00X	000	00X	XXX	00X	000	000	000
	Ammonia in water	30	000	000	000	000	XXX	00X	000	000	000
Acid salt	Ammonium chloride	sat.	000	000	XXX	OXX	000	000	000	000	000
	Zinc chloride	50	000	000	XXX	OXX	000	000	000	000	000
	Iron (III) chloride	50	000	000	- - -	OXX	000	000	000	000	000
Basic salt	Sodium sulfite	sat.	000	000	000	000	- - -	000	000	000	000
	Sodium carbonate	sat.	000	000	000	00X	000	000	000	000	000
Neutral salt	Potassium chloride	sat.	000	000	XXX	000	000	000	000	000	000
	Sodium sulfate	sat.	000	000	000	000	000	000	000	000	000
	Calcium chloride	sat.	000	000	XXX	000	000	000	000	000	000
	Sodium chloride	sat.	000	000	XXX	000	000	000	000	000	000
	Sodium nitrate	50	000	000	XXX	000	000	000	000	000	000
	Aluminium chloride	sat.	000	000	- - -	000	000	000	000	000	000
Oxidizing agent	Hydrogen peroxide	30	000	000	000	00X	000	000	000	000	XXX
	Sodium hypochlorite	50	000	000	XXX	OXX	OXX	000	000	000	000
	Potassium dichromate	sat.	000	000	000	OXX	000	000	000	000	000
	Chlorinated lime		000	OX -	XXX	OXX		000	000	X - -	000
Organic solvent	Ethanol	80	000	00X	000	00X	X - -	000	000	000	000
	Cyclohexane		00	00X	000	00X	000	000	000	000	- - -
	Toluene		000	000	000	00X	- - -	000	000	000	- - -
	Trichloroethane		000	XXX	00X	X - -	XXX	000	000	X - -	- - -
Water		00x	000	000	00X	000	000	000	000	000	000

O = can be used X = shortens useful life - = cannot be used

Note: There are many variables affecting corrosion, making it virtually impossible to compile a conclusive corrosion table applicable under all possible process conditions. The indications in table 2 cannot be used as a recommendation by Yokogawa for the choice of materials. The selection of a suitable material is the sole responsibility of the user. Yokogawa disclaims any reference to this leaflet on that basis.

<p>YOKOGAWA HEADQUARTERS 9-32, Nakacho 2-chome, Musashinoshi Tokyo 180 Japan Tel. (81)-422-52-5535 Fax (81)-422-55-1202 www.yokogawa.com</p>	<p>YOKOGAWA CORPORATION OF AMERICA 2 Dart Road Newnan GA 30265 United States Tel. (1)-770-253-7000 Fax (1)-770-251-2088 www.yokogawa.com/us</p>	<p>Yokogawa has an extensive sales and distribution network. Please refer to the European website (www.yokogawa.com/eu) to contact your nearest representative.</p>
<p>YOKOGAWA EUROPE B.V. Databankweg 20 3821 AL AMERSFOORT The Netherlands Tel. +31-33-4641 611 Fax +31-33-4641 610 www.yokogawa.com/eu</p>	<p>YOKOGAWA ELECTRIC ASIA Pte. Ltd. 5 Bedok South Road Singapore 469270 Singapore Tel. (65)-241-9933 Fax (65)-241-2606 www.yokogawa.com/sg</p>	 <p>YOKOGAWA ◆</p>